



Memorandum

DATE: April 22, 2014

TO: City Council

FROM: Noel Hupprich, Capital Projects Manager II
Public Works Department

CC: Debbie Tarry, City Manager
John Norris, Assistant City Manager
Mark Relph, Public Works Director
Tricia Juhnke, City Engineer
Iain Draper, Engineering Supervisor

RE: City Wayfinding Design Guidelines

INTRODUCTION:

The 2011 Transportation Master Plan identifies the development of a wayfinding signage and mapping system as an important element in the goal to develop a non-motorized transportation system in Shoreline. The City also recognizes the value in a wayfinding system that supports pedestrians and motorists in finding our public facilities and parks.

A project funded by the 2007 six-year King County voter approved trail levy and identified in the 2014-2019 Capital Improvement Plan; the Regional Trail Signage project will create a guiding document and install signage to and from the Interurban trail and to other local and regional trail linkages. The City Wayfinding Design Guidelines document (Attachment A) develops a strategic wayfinding signage plan for pedestrians, bicyclist and motorists. The document outlines policy, provides sign design themes and specifications, identifies destinations, signed routes and proposes sign locations.

Staff and the City's consultant, KPG, have completed the City Wayfinding Design Guidelines and would like to provide the document to Council for your information.

BACKGROUND AND DISCUSSION:

A Wayfinding Steering Committee (WSC) was created consisting of community volunteers, technical consultant and City staff from the Parks, Recreation and

Cultural Services (PRCS) and Public Works Departments. Through several meetings the WSC identified destinations, bicycle routes, developed sign types and specified sign locations.

City staff and KPG used the information gathered at these meetings along with the 2011 Shoreline Bicycle System Plan and the 2011, Shoreline Pedestrian System Plan to create the layout of the signed routes (Attachment B). Wayfinding signs will be installed in phases and only after pedestrian and bicycle facilities are in place. Sign types follow AASHTO and MUTCD guidelines (Attachment C).

While vehicular sign styles and specification are also included in the guidelines, sign locations have not been determined and are not mapped out.

Staff and their technical advisory group presented the results of the WSC meetings to the PRCS Board on October 24, 2013. A public open house was held on December 5, 2013 where the plan and information presented was received positively. Staff reported back to the PRCS Board to present the final City Wayfinding Design Guidelines document on March 27, 2014.

The document is intended as a resource to be used by staff and updated in the future as opportunities arise to further develop the City's wayfinding system through other capital and development projects. Implementation will be completed through phases, with Phase I implementation focusing on signage on or near the Interurban Trail as well as streets with existing bicycle facilities.

The City of Shoreline received approximately \$655,000 from 2007 to 2013 from the 2007 King County Trail Levy. Levy funds can be used for acquisition and development of regional trails and connectors to those trails. The Interurban Trail which runs north and south through Shoreline for 3.25 miles is one of those regional trails. The Regional Trail Signage project will use \$168,491 of the Levy for development of the City Wayfinding Design Guidelines document and Phase I sign implementation. Of that amount, approximately \$117,000 is available for Phase I sign implementation. The other two projects which have used the 2007 King County Trail Levy funds are the Park at Town Center Master Plan and tree planting completed in 2012 and the Echo Lake Improvement Project scheduled to be completed this summer.

Preparation of plans and specifications for Phase I implementation is currently underway. Bid documents are expected to be complete by June, 2014 and construction complete in December, 2014.

ATTACHMENTS:

Attachment A: City Wayfinding Signing Guidelines Document

Attachment B: City Wayfinding Signing Plan

Attachment C: City Wayfinding Sign Family



CITY WAYFINDING SIGNING GUIDELINES

MARCH 2014



ACKNOWLEDGMENTS

The following people contributed their time and expertise to make this document possible:

Mayor Shari Winstead, City Manager Debbie Tarry

City Council:

Deputy Mayor Chris Eggen, Will Hall, Doris McConnell, Keith McGlashan Chris Roberts, Jesse Salomon

Parks, Recreation and Cultural Services Board:

Chair: Katie Beth, Vice-Chair: Jesse Sycuro, John Hoey, Garry Lingerfelt, Betsy Robertson, Christine Southwick, Al Wagar, Vadim Dolgov

Staff Advisory Team

Dick Deal	Director of Parks, Recreation and Cultural Services
Noel Hupprich	Capital Project Manager
Maureen Colaizzi	Parks Project Coordinator
Alicia McIntire	Senior Transportation Planner
Rich Meredith	City Traffic Engineer

Citizen Wayfinding Committee

Mark Davies	Community Volunteer
Andrew Behnke	Community Volunteer
Bill Clements	Community Volunteer
Jesse Sycuro	Community Volunteer

Technical Advisory

Paul Fuesel	KPG
Phuong Nguyen	KPG
Derrek Fields	KPG
Ade Bright	Bright Engineering

TABLE OF CONTENTS

1.0 INTRODUCTION

2.0 PROJECT OVERVIEW

2.1 Project Goals..... 5
2.2 Design Approval Process..... 5
2.3 City Wayfinding System..... 5

3.0 PEDESTRIAN AND BICYCLIST SIGN STANDARDS

3.1 Sign Content..... 7
 3.1-1 Destinations..... 7
 3.1-2 Destination Abbreviations..... 9
 3.1-3 Symbols and Logos..... 10
3.2 Sign Types and Standards..... 11
 3.2-1 Type A: Interurban Trail Directional Sign 13
 3.2-2 Type B2: Shoreline Logo Sign..... 19
 3.2-3 Type B1: City Directional Sign..... 20
 3.2-4 Type C: Confirmation Sign..... 23
 3.2-5 Type D1: Trail Route Sign 25
 3.2-6 Type D2: Single Arrow Auxiliary Sign 27
 3.2-7 Type D3: Double Arrow Auxiliary Sign..... 27
 3.2-8 Type E: Connector Sign 29
3.3 Installation Specifications 31
3.4 Sign Placement Principles..... 33

4.0 VEHICULAR SIGN STANDARDS

4.1. Sign Content..... 35
 4.1-1 Destinations..... 35
 4.1-2 Symbols and Logos..... 35
4.2. Sign Standards..... 35
4.3. Installation Specifications 35
4.4. Sign Placement Principles..... 35

5.0 APPENDICES

A. City Reference Maps..... 37
B. Comprehensive City Wayfinding Signing Plan and Matrix..... 39
C. Interurban / Burke Gilman Connector Routes..... 55



LIST OF TABLES AND FIGURES

Figure 1: Sample of Interurban Trail Wayfinding Sign..... 4

Figure 2: City Wayfinding Signing Plan..... 6

Figure 3: City Wayfinding Destinations Map 8

Figure 4: Symbols and Logos 10

Figure 5: Shoreline Wayfinding Sign Family 12

Figure 6: Double-Sided Interurban Trail Blade 15

Figure 7: Double-Sided Destination Blades..... 16

Figure 8: Double-Sided Destination Blades (Mirrored)..... 17

Figure 9: Single-Sided Shoreline Logo Sign..... 19

Figure 10: Single-Sided Destination Blades..... 22

Figure 11: Confirmation Sign..... 24

Figure 12: Trail Route Sign..... 26

Figure 13: Arrow Auxiliary Signs..... 28

Figure 14: Connector Sign..... 30

Figure 15: Sign Heights for Roadways and Trails 31

Figure 16: Sign Blade Material Widths 32

Figure 17: MUTCD Guidelines for Sign Placement on Shared-Use Paths..... 34

Figure 18: Vehicular Wayfinding Sign..... 36

Figure 19: City Reference Map - Bicycle System Plan 37

Figure 20: City Reference Map - Pedestrian System Plan 38

Figure 21: Comprehensive City Wayfinding Signing Plan..... 39

Figure 22: Interurban / Burke Gilman Connector Routes..... 55

Table 1: City Wayfinding Destinations 7

Table 2: Destination Abbreviations 9

Table 3: Sign Post Height based on AASHTO Vertical Clearances..... 31

Table 4: Standard Clearances for Signs in the Right-of-Way 34

Table 5: City Wayfinding Signing Matrix..... 40-54

THIS PAGE INTENTIONALLY LEFT BLANK



1.0 INTRODUCTION

The City of Shoreline recognizes the need to create a comprehensive city wayfinding signing plan that benefits pedestrians and bicyclists by improving connectivity and fulfilling the community's vision of providing safe transportation alternatives. The wayfinding signing plan may also encourage motorists to use alternatives by providing direction to destinations and additional levels of comfort for those navigating through the City.

The report supports the project goals, outlines policy context, provides sign design themes to enhance the character and identity of the City, identifies destinations, signed routes, and proposes sign locations for a pedestrian and bicyclist wayfinding signing plan.



Figure 1: Sample of Interurban Trail Wayfinding Sign

2.0 PROJECT OVERVIEW

2.1 PROJECT GOALS

- Create a comprehensive wayfinding signing plan for City identified destinations for users on the Interurban Trail and bicyclists on designated bicycle routes within the City
- Enhance the experience of the Interurban Trail and pedestrian environment
- Increase mobility throughout the City, on and off the trails, especially alternative travel modes like walking and biking
- Make information more visually accessible to residents and visitors
- Improve linkages to different destinations, particularly where there seems to be a physical and/or topographical barrier
- Establish wayfinding as part of a unified system to connect to adjacent municipalities and regional trails
- Encourage place-making along the Interurban Trail and around the City of Shoreline

2.2 DESIGN APPROVAL PROCESS

The city wayfinding signing guidelines went through a design/stakeholder approval process where a Wayfinding Steering Committee (WSC), consisting of community volunteers, technical advisory group, City staff members from Parks, Recreation and Cultural Services (PRCS), Planning and Traffic departments, was formed to refine the city wayfinding signing guidelines. Through several meetings the WSC identified significant destinations, developed eight wayfinding sign types, conceptualized the vehicular wayfinding sign standard, specified sign locations and identified bicycle routes that promote a secure wayfinding network for alternative transportation. The city wayfinding signing guidelines were presented to the PRCS Board, to the community at a public open house, to City Council, and again to the PRCS Board for approval.

2.3 CITY WAYFINDING SYSTEM

The Shoreline Bicycle System Plan (2011) and the Shoreline Pedestrian System Plan (2011) provide a framework to layout the signed routes for the city wayfinding signing plan; see Appendix A: City Reference Maps. The city wayfinding sign family also references Shoreline's pilot vehicular wayfinding project and N 175th Street and Meridian Avenue N.

A comprehensive 37-mile network of routes with bicycle facilities and supporting signs map out the city wayfinding signing plan, shown on Figure 2. The interurban trail and signed routes will provide direction across north/south and east/west corridors. Wayfinding signs will be installed in phases and only after necessary pedestrian and bicyclist facilities are in place. The goal of the city wayfinding signing plan is to easily and comfortably guide pedestrians and bicyclists throughout the City of Shoreline.

Designs and final locations for potential kiosks and interpretive signs along the Interurban Trail, shown on Figure 2, will be refined in the future. As additional bicycle routes and signs are designed, implemented and installed, the guidelines will be updated to reflect best practices.

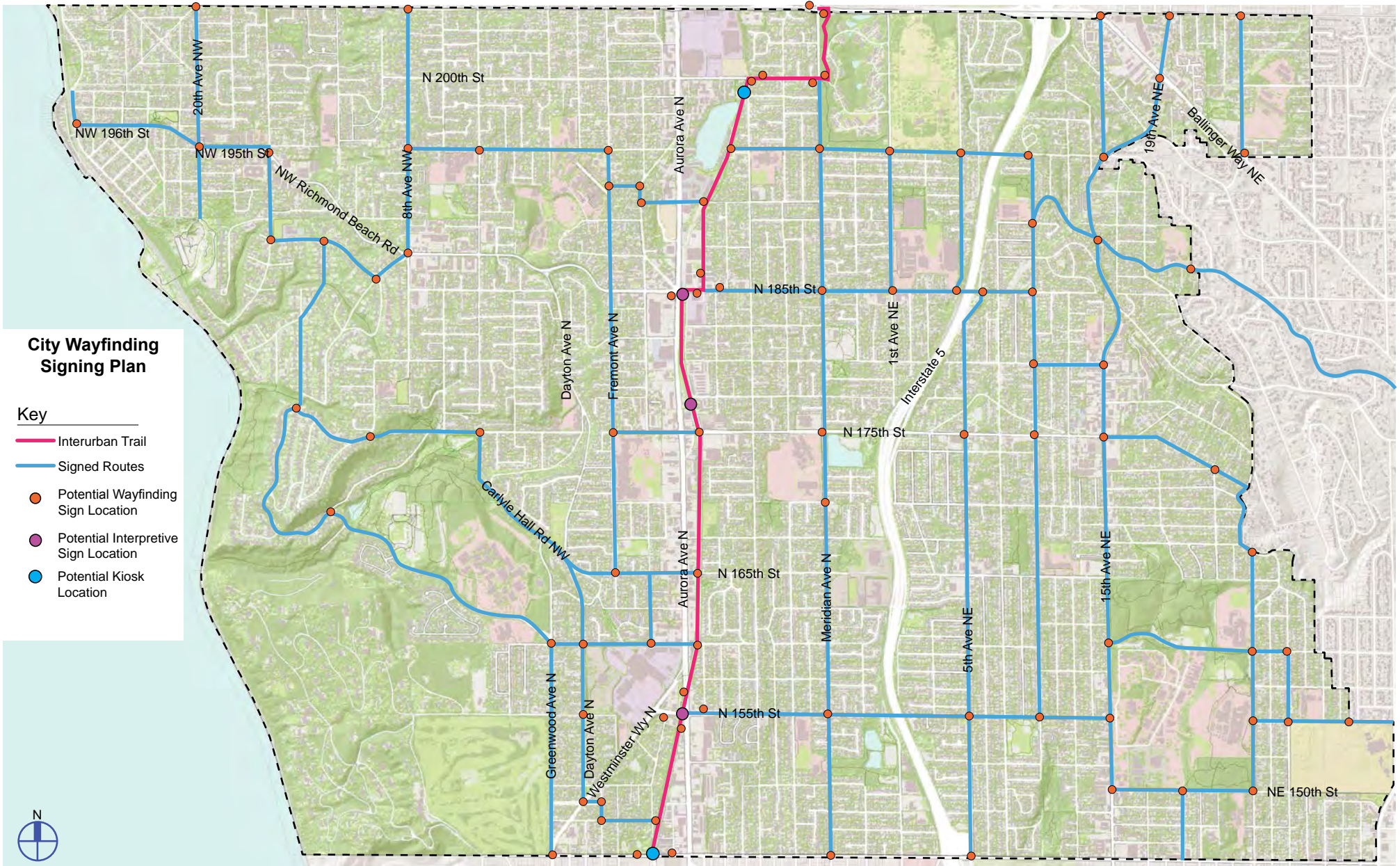

Figure 2: City Wayfinding Signing Plan

3.0 PEDESTRIAN AND BICYCLIST SIGN STANDARDS

3.1 SIGN CONTENT

Wayfinding sign content includes a broad range of destinations, mileages, and symbols and logos. Redundancy in sign content (destination and distance information) should be avoided, and wherever possible signs have been consolidated to one location providing more efficient directions to different points of interests.

3.1-1 Destinations

The WSC established a list of key destinations that would be shown on destination blade signs. Each destination is organized into one of five destination categories: parks, civic, academic, local, and city destinations. These destinations, determined to be important to cyclists and pedestrians, lie within close proximity to signed wayfinding routes and establish a key list of Shoreline destinations.

The WSC recognized that providing names of individual commercial businesses, private institutions, restaurants and other non-public destinations would be problematic. The large number of these types of destinations throughout the City as well as limited space on the signs makes it challenging to be entirely inclusive. Additional wayfinding signage may be installed as new destinations, such as the Sound Transit light rail stations, are developed in the future.

<i>Park Destinations</i>	<i>Civic Destinations</i>	<i>Academic Destinations</i>
1. Kayu Kayu Ac Park	22. Richmond Beach Library	41. Shoreline Community College
2. Richmond Beach Community Park	23. WA State Department of Transportation	42. Shorewood High School
3. Richmond Beach Saltwater Park	24. Post Office	43. Shorecrest High School
4. Kruckeberg Botanic Garden	25. Town Center (175th & Aurora)	
5. Boeing Creek Open Space	26. Shoreline City Hall/Police Department	<i>Local Destinations</i>
6. Shoreview Park	27. Shoreline Historical Museum	44. Aurora Square
7. Boeing Creek Park	28. Department of Licensing	45. Aurora Village
8. Hillwood Park	29. Shoreline Park-n-Ride	46. North City
9. Richmond Highlands Recreation Center	30. Town Center (175th & Aurora)	47. Richmond Beach
10. Echo Lake Park	31. Aurora Village Transit Center	
11. Meridian Park Turf Field	32. King County District Court	<i>City Destinations</i>
12. Cromwell Park	33. Shoreline Library	48. To Woodway
13. Shoreline Park	34. Community, Police, Storefront	49. To Edmonds
14. Ridgcrest Park	35. Post Office	50. To Edmonds, Lynnwood, Mountlake Terrace and Interurban Trail
15. Twin Ponds Park	36. State of Washington Fircrest School	51. To Lake Forest Park and Burke Gilman Trail
16. Paramount School Park	37. Public Health Lab	52. To Seattle
17. Hamlin Park	38. Spartan Recreation Center	53. To Seattle
18. Eastside Off Leash Dog Park	39. Shoreline Pool	54. To Seattle
19. South Woods	40. Shoreline Stadium	55. To Seattle and Interurban Trail
20. To Burke Gilman Trail		56. To Seattle
21. Sunset School Park		

Table 1: City Wayfinding Destinations



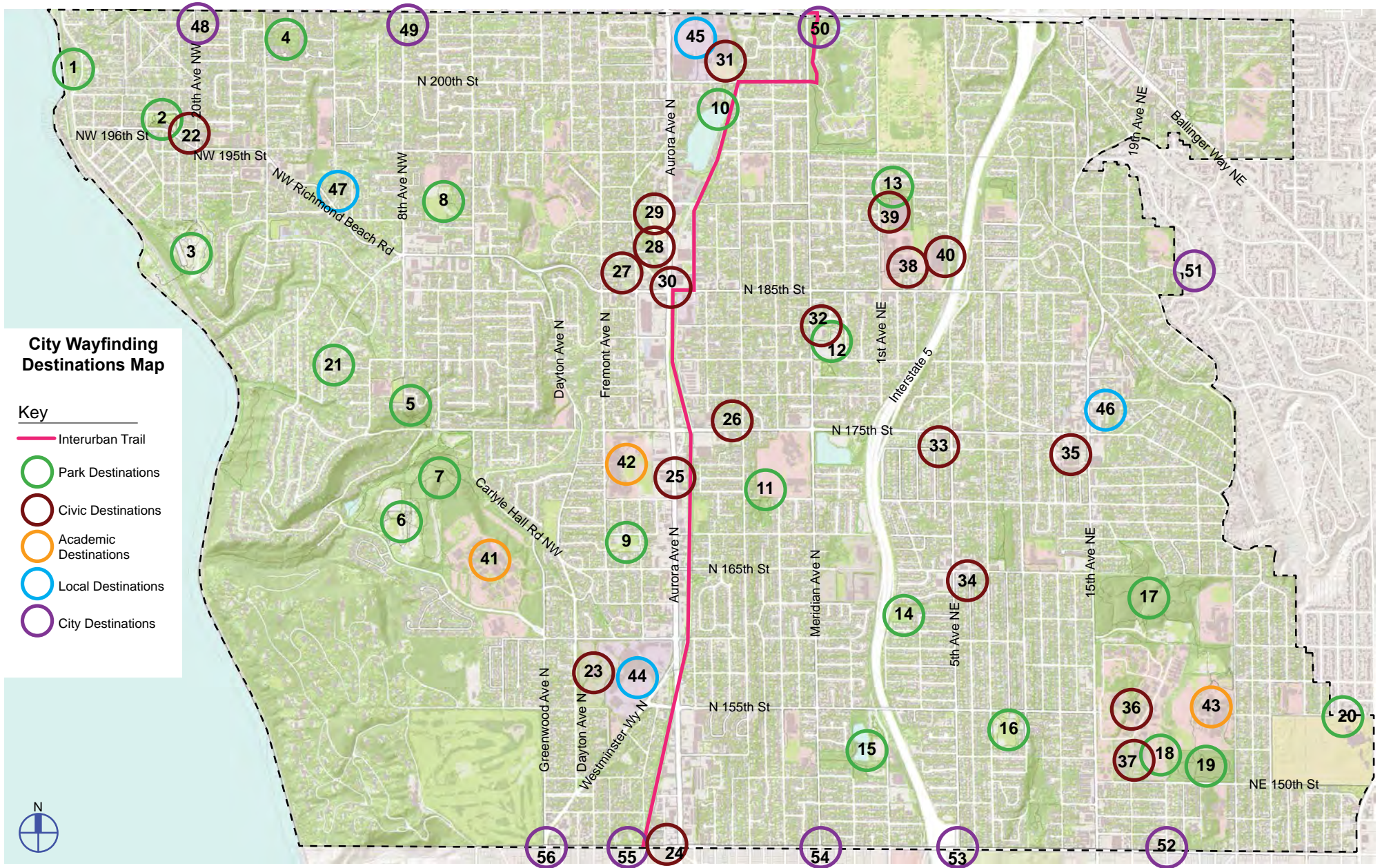

Figure 3: City Wayfinding Destinations Map

3.1-2 Abbreviations

The WSC established a list abbreviations and shortened texts for certain destinations in order to compensate for multiple words and long characters. In the case where a destination has the City’s name, it should be withheld from destination blade text (i.e. “Shoreline Police Station” becomes “Police Station”). There are three exceptions in which the City’s name should be used: Shoreline Pool, Shoreline Stadium, and Shoreline Community College.

A period will not be placed after an abbreviated destination to conserve character space on signs (i.e. Dept, not Dept.). The WSC determined that signs directing users to Richmond Beach destinations will be signed as “Richmond Beach” until you arrive at the intersection of NW 195th Street and 15th Avenue NW. At this point individual destinations names for the Richmond Beach neighborhood will be used.

The abbreviations and shortened texts should be consistent throughout the city wayfinding signing plan and destination list. See Table 2 below for a complete list of abbreviations and shortened texts.

Original Text	Abbreviated/Shortened Text
Richmond Beach Community Park	RB Community Park
Richmond Beach Saltwater Park	RB Saltwater Park
Kruckeberg Botanic Garden	Kruckeberg Garden
Richmond Highlands Recreation Center	Richmond Highlands Rec
Meridian Park Turf Field	Meridian Park Field
Eastside Off Leash Dog Park	Off Leash Dog Park
Richmond Beach Library	RB Library
Washington State Department of Transportation	WSDOT
Town Center	Town Cntr
Shoreline City Hall	City Hall
Shoreline Historical Museum	Historical Museum
Department of Licensing	Dept of Licensing
Shoreline Police Department	Police Dept
Aurora Village Transit Center	Transit Cntr
King County District Court	District Court
State of Washington Fircrest School	Fircrest School
Spartan Recreation Center	Spartan Rec Cntr
Shoreline Community College	Shoreline CC
Shorewood High School	Shorewood HS
Shorecrest High School	Shorecrest HS

Table 2: Destination Abbreviations



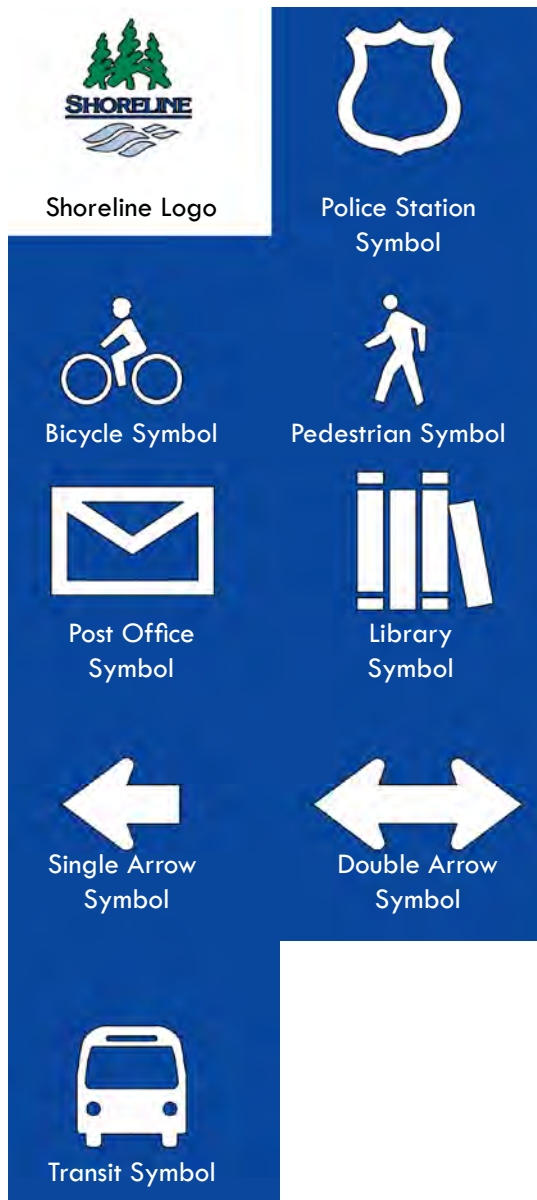

Figure 4: Symbols and Logos

3.1-3 Symbols and Logos

Each sign type in the city wayfinding signing plan have a symbol, a combination of symbols, or the City of Shoreline’s logo. The following list of ten destinations will receive a single arrow symbol and bicycle symbol on both the double-sided and single-sided destination blades (Sign Types A and B1):

- | | | |
|-------------------|------------------------------|-----------------------|
| 1. Town Center | 5. Shorecrest High School | 9. Shoreline Pool |
| 2. Shoreview Park | 6. Shorewood High School | 10. Shoreline Stadium |
| 3. Hamlin Park | 7. Interurban Trail | |
| 4. City Hall | 8. Spartan Recreation Center | |

On a destination blade that receives both the arrow and bicycle symbols it will also depict the mileage to that particular destination. The Interurban Trail destination blades will only depict mileage up to 0.5 miles from trail. The WSC specified only these ten destinations will highlight mileage information as they are key destinations for the City. All logos are oriented the same direction as the arrow.

Destinations and Signs that Receive Symbols

1. Police Symbol: Shoreline Police Department
2. Post Office Symbol: Post Office
3. Library Symbol: Shoreline Library, Richmond Beach Library
4. Bicycle Symbol: The ten destinations that receive mileage information (listed above), and Sign Types C, D1, and E
5. Pedestrian Symbol: Not specific to any destination, for Sign Types D1 and E only
6. Single Arrow Symbol: Occurs on all destination sign blades, and Sign Type D2
7. Double Arrow Symbol: Not specific to any destination, for Sign Type D3 only
8. Transit Symbol: Aurora Village Transit Center, Shoreline Park-n-Ride
9. Shoreline Logo: Interurban Trail Sign Blade (Type A) and Shoreline Logo Sign (Type B2) only

Color

1. Shoreline Logo
 - A. Trees: Green; R-0, G-128, B-77
 - B. Text with Line: Blue; R-10, G-71, B-157
 - C. Waves: Gradient of Blues with darker blue starting from left edge
 - a. Darker Blue; R-151, G- 178, B-218
 - b. Lighter Blue; R-201, G-215, B-233

2. Symbols

- A. All symbols: White; R-255, G-255, B-255

Size

1. Symbol and logo sizes vary per each sign type, see Figures 6-14 for size details.

3.2 SIGN TYPES AND STANDARDS

The city wayfinding signing plan will provide pedestrians and bicyclists with direction, destination and distance information as well as establish bicycle routes. In assisting cyclists and pedestrians, the city wayfinding signing plan will provide guidance through the use of eight sign types:

1. *Type A: Interurban Trail Directional Signs:* Occurs at major decision points, and intersections, along the Interurban Trail to provide directional guidance and primary destination information.
2. *Type B1: City Directional Signs:* Occurs at decision points along primary on-street cyclist routes (as specified by the WSC) to provide directional guidance and primary destination information at intersections.
3. *Type B2: Shoreline Logo Sign:* Occurs at the City border along primary cyclist routes to inform cyclist upon entering Shoreline. This sign type will be mounted on top of sign Type B1.
4. *Type C: Confirmation Signs:* Occurs along primary cyclist routes to confirm upcoming municipality and route choice for exiting Shoreline, and if paired with sign Type D2, or D3, can provide additional guidance at turns.
5. *Type D1: Trail Route Signs:* Directs riders to Interurban Trail from the street.
6. *Type D2: Single Arrow Auxiliary Signs:* Supplemental sign providing direction at turn points and intersections. This sign type will be mounted below sign Type C, D1, or E.
7. *Type D3: Double Arrow Auxiliary Signs:* Supplemental sign providing direction at turn points and intersections. This sign type will be mounted below sign Type C, D1, or E.
8. *Type E: Connector Sign:* Occurs along primary cyclist routes to direct cyclists to the Interurban / Burke Gilman Connector route, and occurs along the Interurban / Burke Gilman Connector route to confirm cyclist is on the connector route.

The city wayfinding sign family adopts a color scheme that establishes uniformity among the sign types and reinforces Shoreline's logo and identity. Sections 3.2-1 through 3.2-8 specify individual sign colors using the RGB color system. The RGB color system is a composition of three primary colors: red (R), green (G), and blue (B). Each color in the RGB spectrum is created first by having a dark canvas (or design area) and then adding each of the red, green and blue elements. For this reason it is also known as the Additive Color System.

The eight sign types have been modeled from the bicycle sign standards currently found in the Manual on Uniform Traffic Control Devices (MUTCD) guidelines for directional bicycle signage in part, with a few modifications for identity enhancement and branding. More informing documents include the following:

- *MUTCD, 2009*
- *AASHTO Guide for the Development of Bicycle Facilities, 2012 – 4th Edition*

Vehicular Wayfinding Sign



Refer to Section 4.0 for Vehicular Wayfinding Sign details.

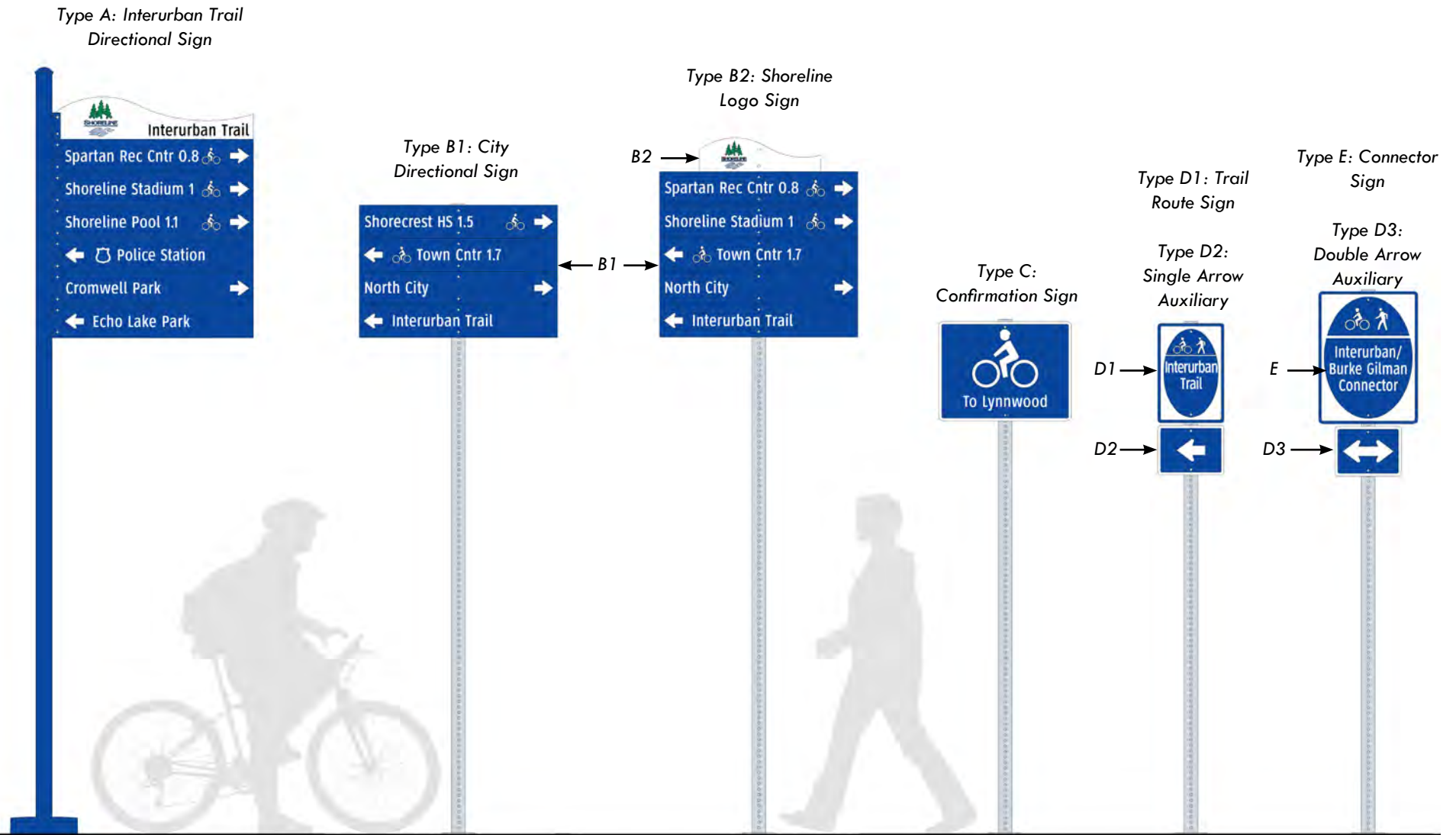

Figure 5: City Wayfinding Sign Family

3.2-1 Interurban Trail Directional Sign

Interurban Trail Directional signs include a double-sided Interurban Trail blade (with City logo), double-sided destination blades with directional arrows, symbols, destination names and mileage information.

Sign Blades

1. Interurban Trail Blade (see Figure 6)
 - A. Color: White; R-255, G-255, B-255
 - B. Located above all Destination Blades.
 - C. Blades are doubled-sided
2. Destination Blades (see Figure 7 and 8)
 - A. Color: Blue; R-10, G-71, B-157
 - B. Blades are double-sided

Sign Content

1. Destinations
 - A. There is a maximum of 6 destination blades (one destination per blade), with or without mileage, per sign pole location.
2. Text: Interurban Trail Blade
 - A. Will always read “Interurban Trail”
 - B. Color: Black; R-0, G-0, B-0
 - C. Font: Clearview Highway Type C, 2-inch cap height
 - D. First letter of each word capitalized, remaining letters lower case
 - E. Alignment: centered on low arc
3. Text: Destination Blades
 - A. Maximum characters per destination blade (includes characters for mileage, where applicable): 17-23, see Figures 7 and 8 for maximum character details
 - B. First letter of each word capitalized, remaining letters lower case
 - C. Font: Clearview Highway Type C, 2-inch cap height
 - D. Color: White; R-255, G-255, B-255
 - E. Alignment: justified left
 - F. Double-sided blade text varies per sign location. Text variations for a single blade may include (on either side): same destination, two different destinations, single destination and blank side. Refer to wayfinding matrix in Appendix B for destination text content.
4. Mileage
 - A. Mileages will be illustrated in whole numbers and decimals rounded to the nearest tenth (i.e. 0.8, 1.5, 3.0). In the instance where character space is severely limited on a sign blade, whole numbers can be reduced to whole numbers only (i.e., 2 rather than 2.0). Distance measurements are made from the intersection at which the sign will be located to the nearest point/point of

entrance to a given destination.

B. Font: Clearview Highway Type C, 2-inch cap height

C. Color: White; R-255, G-255, B-255

D. Mileages will be located immediately following destination text with one character space separation.

5. Logos and Symbols

A. Shoreline city logo is located on the Interurban Trail Blade only.

B. Refer to section 3.1-3 for complete list of symbols and specifications on destinations that receive symbols. Refer to Appendix B for sign locations, destination information, and arrow direction. Size symbols as noted in Figures 5 and 6.

C. Bicycle symbol is always oriented in the direction the arrow is pointing.

D. Single arrow symbols to be placed on each destination blade, sized as noted in Figures 5 and 6.

E. Symbols color: White; R-255, G-255, B-255

Organization of Sign Content

1. Destination is straight ahead: arrow is left justified with bicycle logo to the right. Text is left justified, immediately following symbols, followed by mileage.
2. Destination is to the right: arrow is right justified with bicycle logo to the left. Text is left justified followed by mileage.
3. Destination is to the left: arrow is left justified with bicycle logo to the right. Text is left justified, immediately following symbols, followed by mileage.

Organization of Signs within a Sign Assembly

1. The sign with the nearest destination goes at the top of the assembly with the most distant destination at the bottom. If destinations are equal in distance, the sign with a straight ahead arrow should be placed on top. This arrangement allows for the nearest destination to “fall off” the top of the sign and subsequent destinations to move-up as the cyclist approaches.
2. The number of signs on a given post pointing in the same direction is not to exceed four. Limiting destinations to two in one direction is necessary to provide space for destinations in other directions as this sign type will occur at intersecting routes.
3. The number of destinations provided on a given post is not to exceed six. This allows for the proper vertical clearance of 7'-6" to be maintained.

Sign Placement

1. Interurban Trail Directional signs are placed at decision points along the trail where signed routes and arterial roadways intersect the Interurban Trail.
2. Signs are to be located at trail splits.

3. Placing signs at these locations reinforces the use of designated routes from the Interurban Trail. The regional wayfinding system has been designed to connect parks and open spaces, civic, academic and local destinations, and important locations beyond the City of Shoreline that in many cases fall directly on a designated route.
4. Sign Location
 - A. 24" minimum setback from back of curb or edge of sidewalk pavement
 - B. 5' minimum setback from driveways

Sign Type A: Interurban Trail Blade
Interurban Trail Directional Signs, Custom Size

Clearview Highway Type C, 2" caps
 1.5" radius, 0.5" border

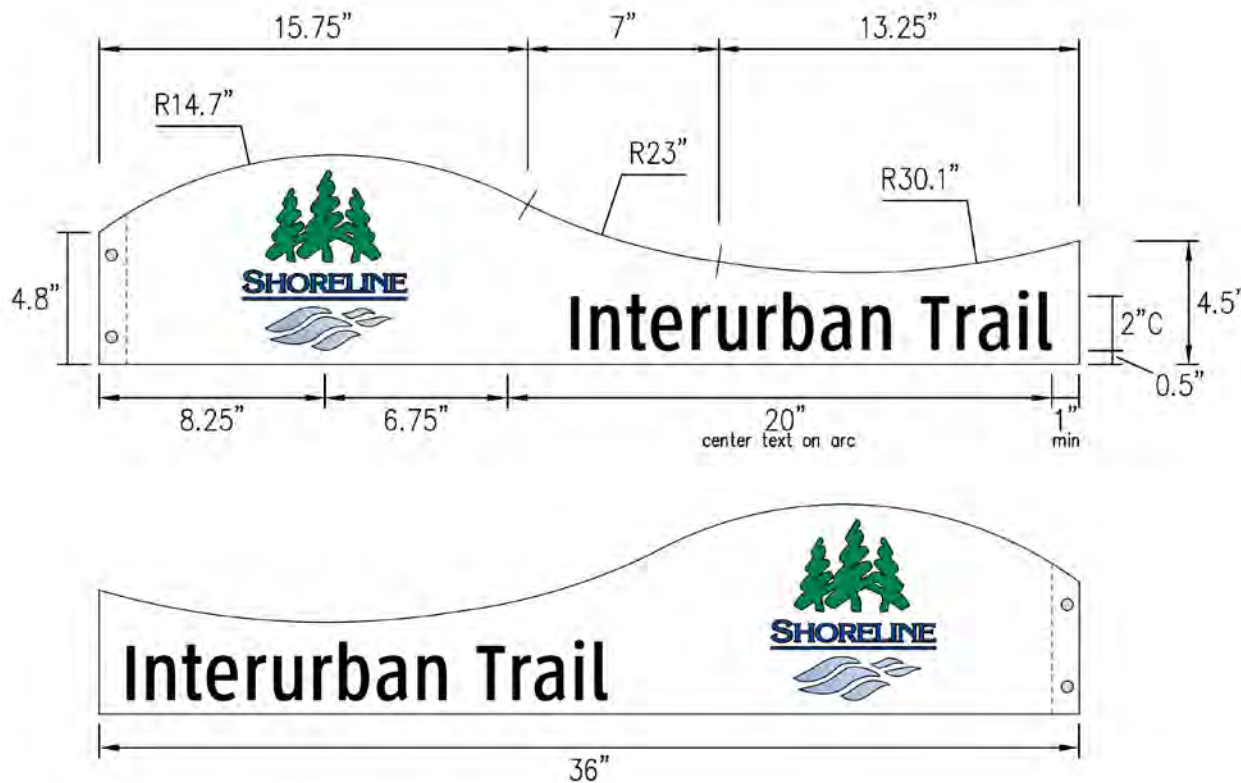

Figure 6: Double-Sided Interurban Trail Blade

Sign Type A: Destination Blade
Interurban Trail Directional Signs, 36" x 6"

Clearview Highway Type C, 2" caps
 1.5" radius, 0.5" border

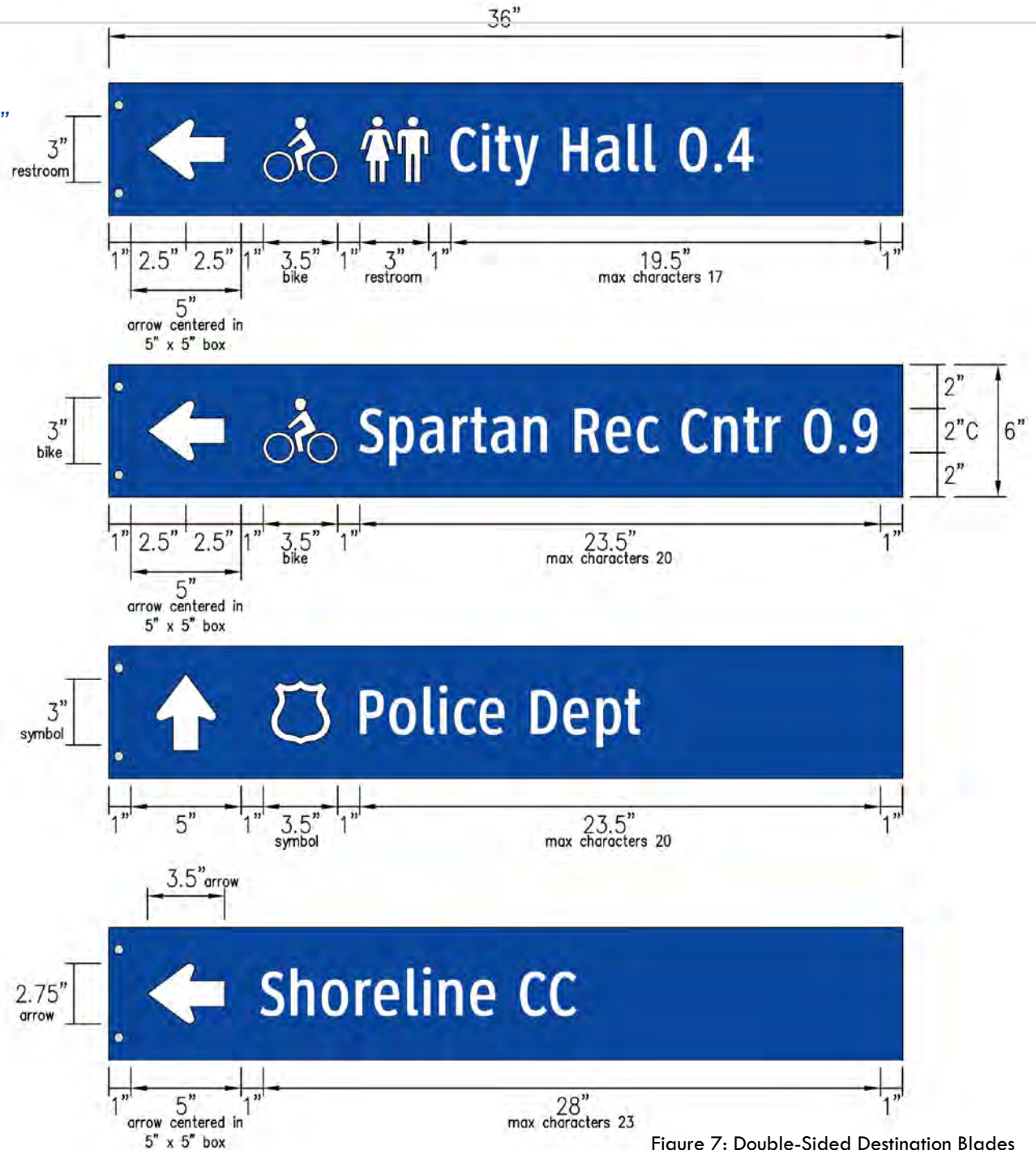
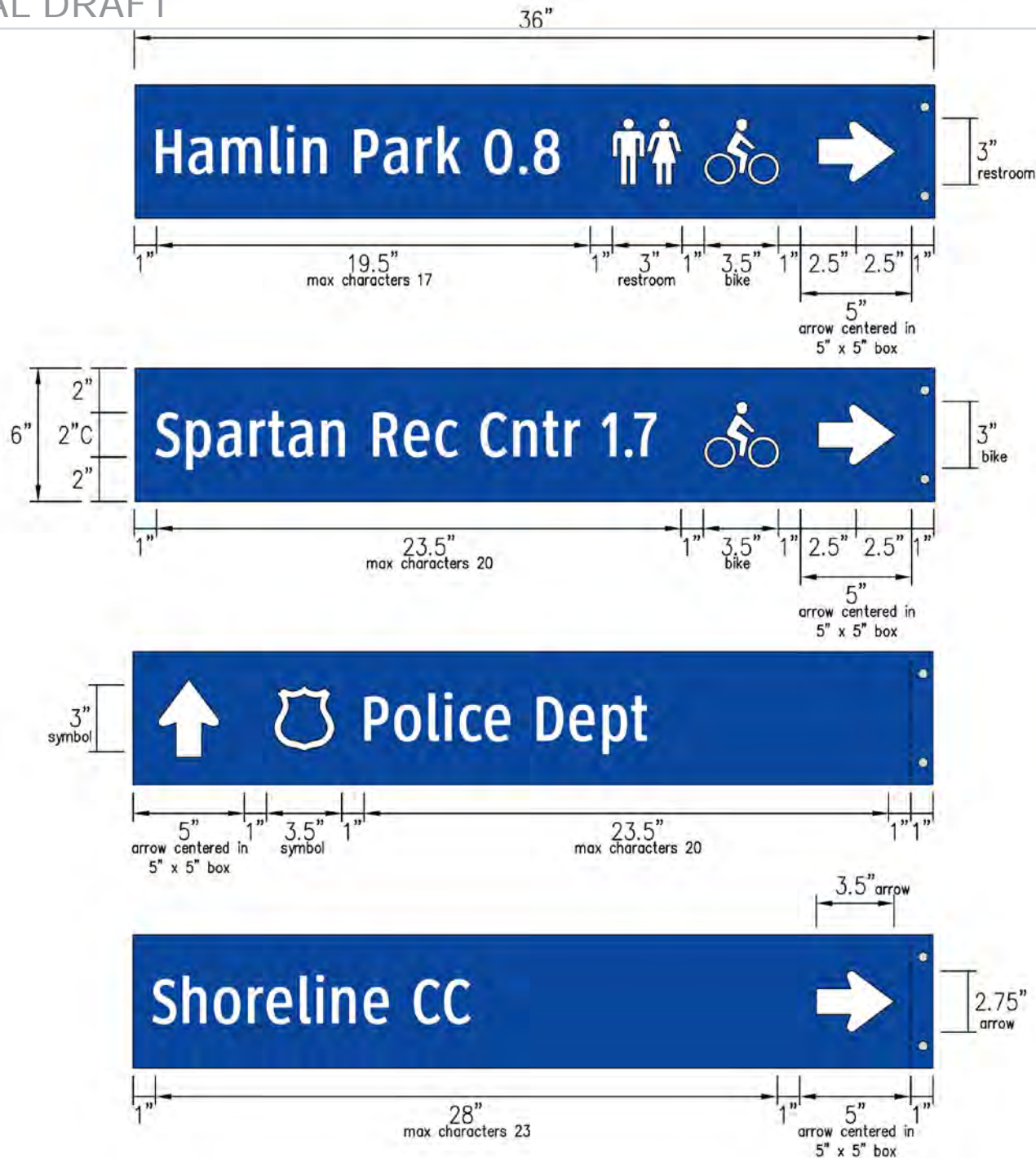

Figure 7: Double-Sided Destination Blades



Sign Type A: Destination Blade (Mirrored)
Interurban Trail Directional Signs, 36" x 6"

Clearview Highway Type C, 2" caps
 1.5" radius, 0.5" border

Figure 8: Double-Sided Destination Blades (Mirrored)

THIS PAGE INTENTIONALLY LEFT BLANK

3.2-2 Shoreline Logo Sign

Shoreline Logo signs are single-sided, include only the City logo and occur only at the City border along primary cyclist routes to inform cyclist upon entering Shoreline.

Sign

1. Color: White; R-255, G-255, B-255

Sign Content

1. Logo
 - A. Each logo sign will have one Shoreline logo, and shall be centered on the sign and sized according to Figure 10 below.
 - B. See section 3.1-3 for logo.

Organization of Signs within a Sign Assembly

1. The sign is paired with Sign Type B1, City Directional Sign, and is located above all directional blades and accompanying supplemental signs.

Sign Placement

1. Shoreline Logo Signs occur only at the City border.
2. Sign Location
 - A. 24" minimum setback from back of curb or edge of sidewalk pavement
 - B. 5' minimum setback from driveways
 - C. 100' minimum setback from intersections

Sign Type B2

Shoreline Logo Sign, Custom Size

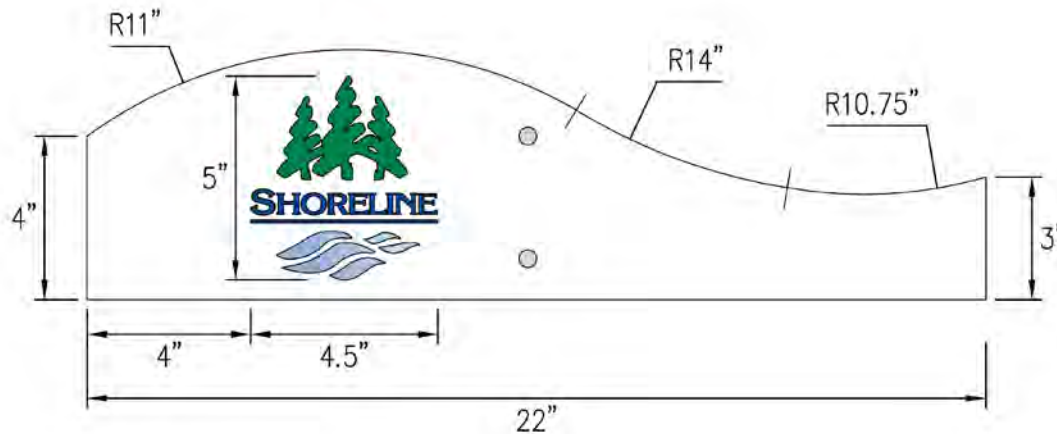

Figure 9: Single-Sided Shoreline Logo Sign

3.2-3 City Directional Sign

City directional signs are single-sided destination blades that include directional arrows, symbols, destination names, and mileage information.

Sign Blades

1. Color: Blue; R-10, G-71, B-157

Sign Content

1. Destinations
 - A. There is a maximum of 6 destination blades (one destination per blade), with or without mileage, per sign pole location.
2. Text: Destination Blades
 - A. Maximum characters per destination blade (includes characters for mileage, where applicable): 18 - 23, see Figure 9 for maximum character details
 - B. First letter of each word capitalized, remaining letters lower case
 - C. Font: Clearview Highway Type C, 2-inch cap height
 - D. Color: White; R-255, G-255, B-255
 - E. Alignment: justified left
3. Mileage: Destination Blades
 - A. Mileages will be illustrated in whole numbers and decimals rounded to the nearest tenth (i.e. 0.8, 1.5, 3.0). In the instance where character space is severely limited on a sign blade, whole numbers can be reduced to whole numbers only (i.e., 2 rather than 2.0). Distance measurements are made from the intersection at which the sign will be located to the nearest point/point of entrance to a given destination.
 - B. Font: Clearview Highway Type C, 2-inch cap height
 - C. Color: White; R-255, G-255, B-255
 - D. Mileages will be located immediately following destination text with a one character space separation.
4. Symbols: Destination Blades
 - A. Refer to section 3.1-3 for complete list of symbols and specifications on destinations that receive symbols. Refer to Appendix B for sign locations, destination information, and arrow direction. Size symbols as noted in Figure 9.
 - B. Bicycle symbol is always oriented in the direction the arrow is pointing.
 - C. Single arrow symbols to be placed on each destination blade, sized as noted in Figure 9.
 - D. Color: White; R-255, G-255, B-255

Organization of Sign Content

1. Destination is straight ahead: arrow is left justified with bicycle logo to the right. Text is left justified,

immediately following symbols, followed by mileage.

2. Destination is to the right: arrow is right justified with bicycle logo to the left. Text is left justified followed by mileage.
3. Destination is to the left: arrow is left justified with bicycle logo to the right. Text is left justified, immediately following symbols, followed by mileage.

Organization of Signs within a Sign Assembly

1. The sign with the nearest destination goes at the top of the assembly with the most distant destination at the bottom. If destinations are equal in distance, the sign with a straight ahead arrow should be placed on top. This arrangement allows for the nearest destination to “fall off” the top of the sign and subsequent destinations to move-up as the cyclist approaches.
2. The number of signs on a given post pointing in the same direction is not to exceed four. Limiting destinations to two in one direction is necessary to provide space for destinations in other directions as this sign type will occur at intersecting routes.
3. The number of destinations provided on a given post is not to exceed six. This allows for the proper vertical clearance to be maintained.

Sign Placement

1. City directional signs are placed at decision points where signed routes intersect and where routes lead directly to the intended destination. Placing signs at these locations reinforces the use of the designated routes. The city wayfinding system has been designed to connect parks and open spaces, civic, academic and local destinations, and important locations beyond the City of Shoreline that in many cases fall directly on signed routes.
2. When city directional signs are placed on regional routes or they point users directly to signed routes, Trail Route Signs (Sign Type D1) may be placed on the same sign post below the blades. Placing multiple sign types on one post will reduce the number of posts used as well as provide all necessary information for bicyclists in one location.
3. Signs are placed at the approach to an intersection route:
 - A. 100' before an intersecting route
 - B. 200' on a two lane merge within the block approaching the intersection route
4. Sign Location
 - A. 24" minimum setback from back of curb or edge of sidewalk pavement
 - B. 5' minimum setback from driveways
 - C. 100' minimum setback from intersections

Sign Type B1: Destination Blades
 City Directional Signs, 36" x 6"

Clearview Highway Type C, 2" caps
 1.5" radius, 0.5" border

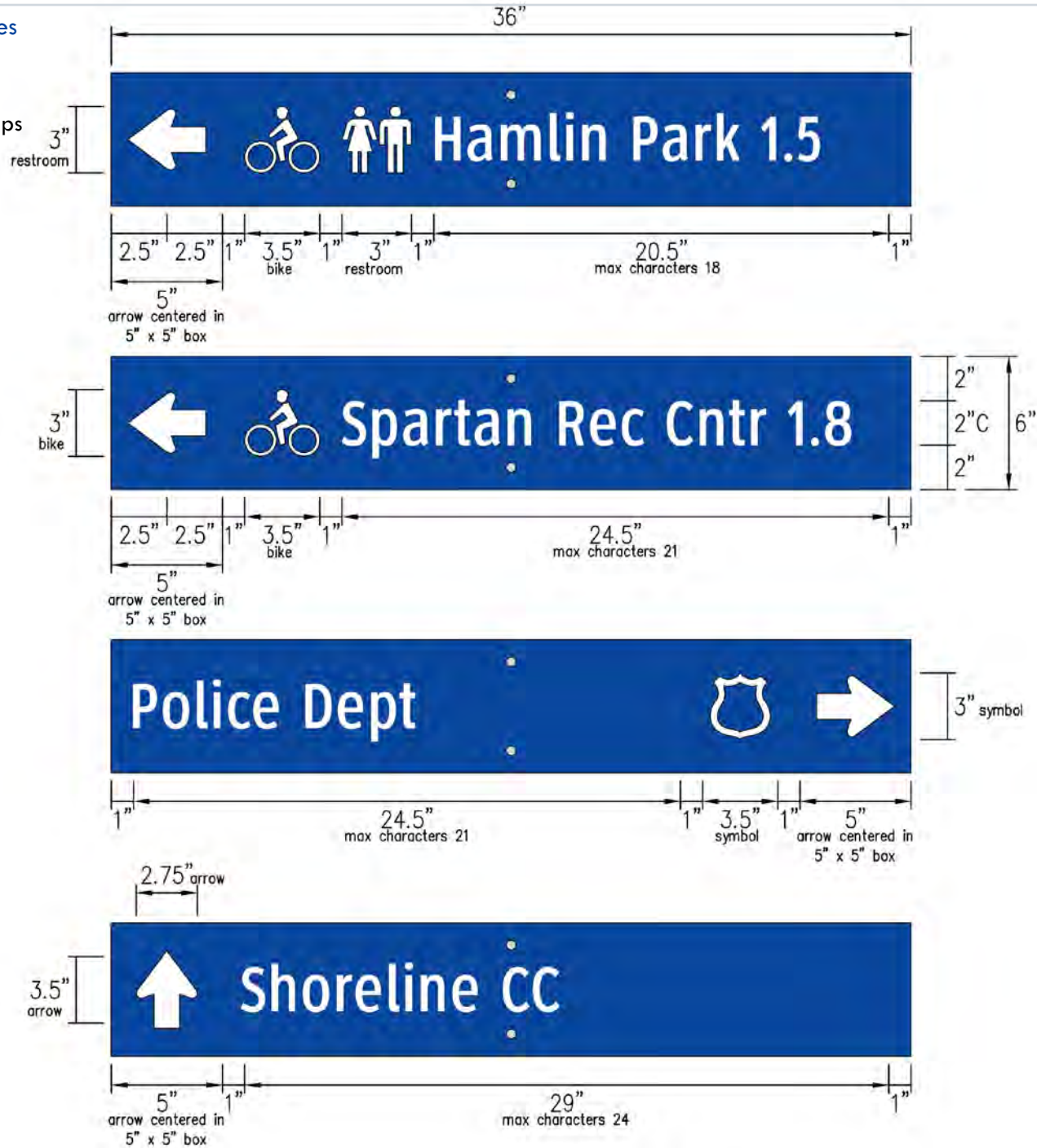

Figure 10: Single-Sided Destination Blades

3.2-4 Confirmation Sign

Confirmation signs confirm route choice and provide guidance upon entering an adjacent municipality. They can also be used with an auxiliary arrow sign (Sign Type D2 or D3) to provide direction at a turn in a route that is not a regional route. Confirmation signs include destination information generally with the text “To” before the location indicated on the sign. In cases where a confirmation sign is found on a signed route and the route must be confirmed after a turn has been made, a trail route sign (Sign Type D1) may be placed below the confirmation sign.

Sign

1. Color: Blue; R-10, G-71, B-157
2. Border color: White; R-255, G-255, B-255

Sign Content

1. Text

- A. Maximum characters: 17
- B. Two lines of text may be used where necessary. If two lines are needed the text should be centered vertically in the 6” space from the bottom of sign to the bottom of the bicycle symbol.
- C. First letter of each word capitalized, remaining letters lower case
- D. Font: Clearview Highway Type C, 2-inch cap height
- E. Color: White
- F. Alignment: Centered

2. Symbols

- A. Bicycle symbol, sized as noted in Figure 11. The bicycle symbol is always oriented to point to the left edge of the sign.
- B. See section 3.1-3 for symbol.
- C. Color: White; R-255, G-255, B-255

Sign Placement

1. 30’-60’ before Shoreline border, whether it be a street/street intersection or a street/boundary intersection.
2. Sign Location
 - A. 24” minimum setback from back of curb or edge of sidewalk pavement
 - B. 5’ minimum setback from driveways
 - C. 100’ minimum setback from intersections

Sign Type C
Confirmation Sign, 24" x 18"

Clearview Highway Type C, 2" caps
1.5" radius, 0.5" border

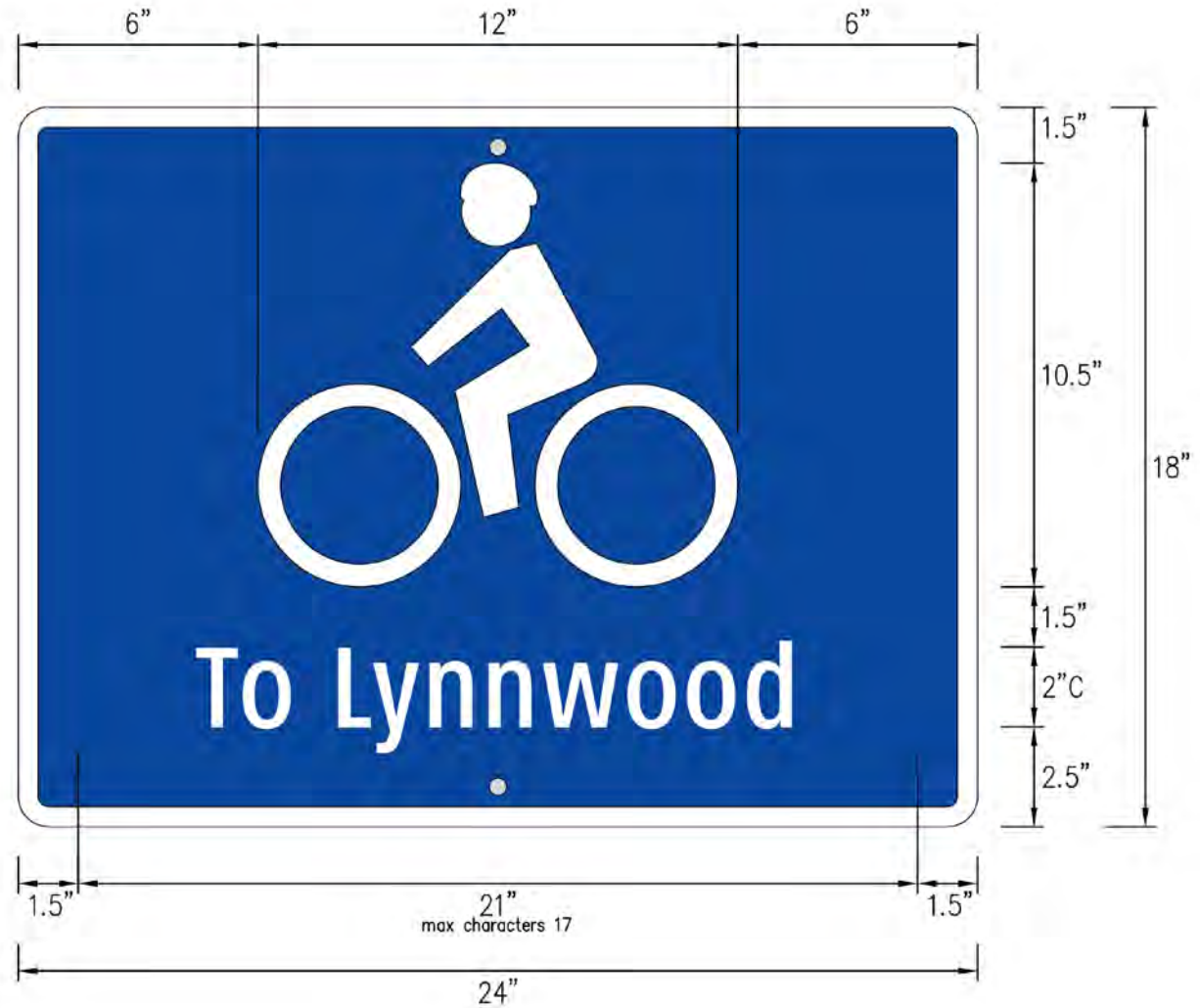

Figure 11: Confirmation Sign

3.2-5 Trail Route Sign

Trail Route signs direct pedestrians and cyclists to the Interurban Trail from the street. Trail route signs are used in conjunction with auxiliary signs Type D2 or D3 (reference MUTCD M7 sign series) to inform users of proper direction to the trail.

Sign

1. Border and oval color: Blue; R-10, G-71, B-157
2. Internal color: White; R-255, G-255, B-255

Sign Content

1. Text

- A. Top line reads "Interurban", middle line reads "Trail", and bottom line is unused
- B. First letter of each word capitalized, remaining letters lower case
- C. Font: Clearview Highway Type C, 2-inch cap height
- D. Color: White; R-255, G-255, B-255
- E. Alignment: Centered

2. Symbols

- A. Bicycle symbol, sized as noted in Figure 12. The bicycle symbol is always oriented to point to the left edge of the sign.
- B. Pedestrian symbol, sized as noted in Figure 12. The pedestrian symbol is always oriented to point to the left edge of sign.
- C. Symbol order when arrow points left, from left to right, bicycle - pedestrian
- D. Symbol order when arrow points right, from left to right, pedestrian - bicycle
- E. Symbol order when there is a double arrow, from left to right, bicycle - pedestrian
- F. See section 3.1-3 for symbols.
- G. Color: White; R-255, G-255, B-255

Organization of Signs within a Sign Assembly

1. The sign is located above Sign Types D2 and D3, but, when applicable, is located below Sign Types C and B1.

Sign Placement

1. 30'-60' before intersection of Interurban Trail and signed street route.
2. Sign Location
 - A. 24" minimum setback from back of curb or edge of sidewalk pavement
 - B. 5' minimum setback from driveways
 - C. 100' minimum setback from intersections

Sign Type D1
Trail Route Sign, 12" x 18"

Clearview Highway Type C, 2" caps
1.5" radius, 0.5" border



Figure 12: Trail Route Sign

3.2-6 Single Arrow Auxiliary Sign

Single arrow auxiliary signs are supplemental signs providing direction at decision points, turn points, and intersections. This sign type is mounted with Sign Type C, D1, or E.

Sign

1. Color: Blue; R-10, G-71, B-157
2. Border color: White; R-255, G-255, B-255

Sign Content

1. Symbol
 - A. Single arrow symbol, sized as noted in Figure 13.
 - B. See section 3.1-3 for symbol.
 - C. Color: White; R-255, G-255, B-255

Organization of Signs within a Sign Assembly

1. The sign is located below all other sign types on any give post.

Sign Placement

1. Refer to sign placements for Sign Types C, D1, or E.

3.2-7 Double Arrow Auxiliary Sign

Double arrow auxiliary signs are supplemental signs providing direction at decision points, turn points, and intersections. This sign type is mounted with Sign Type C, D1, or E.

Sign

1. Color: Blue; R-10, G-71, B-157
2. Border color: White; R-255, G-255, B-255

Sign Content

1. Symbol
 - A. Double arrow symbol, sized as noted in Figure 13.
 - B. See section 3.1-3 for symbol.
 - C. Color: White; R-255, G-255, B-255

Organization of Signs within a Sign Assembly

1. The sign is located below all other sign types on any give post.

Sign Placement

1. Refer to sign placements for Sign Types C, D1, or E.

Sign Types D2 and D3
Arrow Auxiliary Signs, 12" x 9"

1.5" radius, 0.5" border

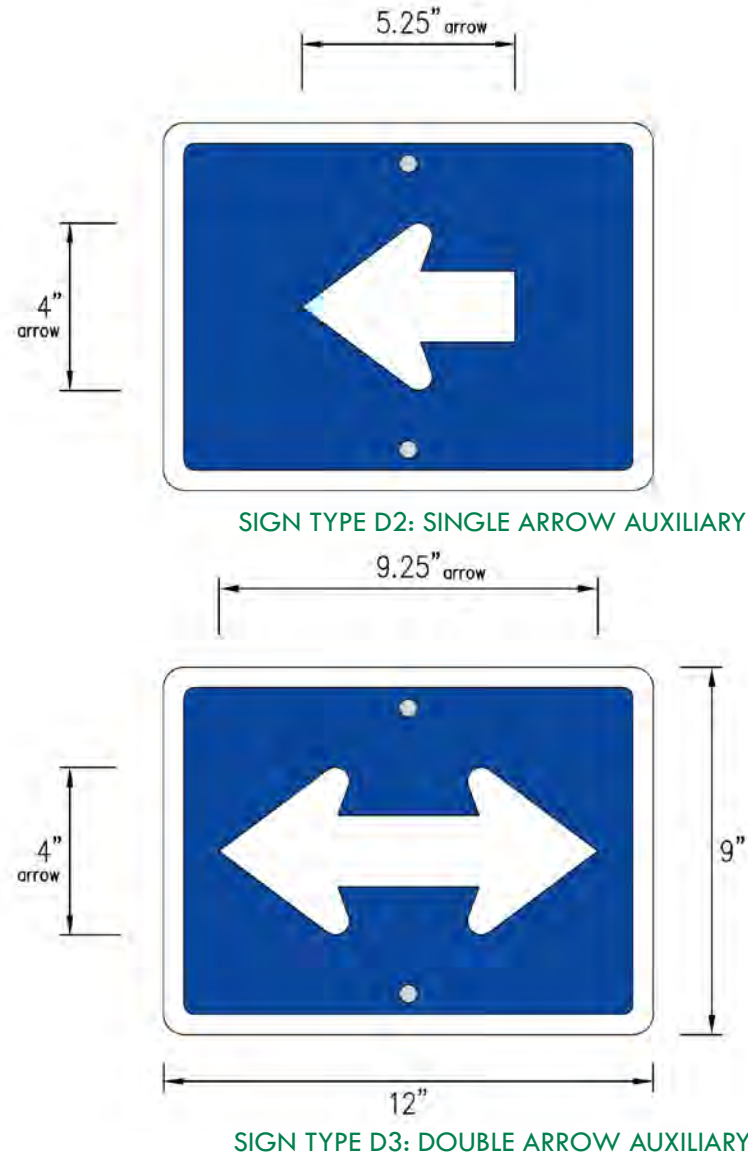

Figure 13: Arrow Auxiliary Signs

3.2-8 Connector Sign

Connector signs occur along signed routes to direct cyclists and pedestrians to the Interurban / Burke Gilman Connector Routes. They also occur on signed routes between the Interurban Trail and Burke Gilman Trail to confirm the user is on the connector route. Connector signs are used in conjunction with auxiliary signs Type D2 or D3 to inform users of proper direction to the trail. See Figure 22: Interurban / Burke Gilman Connector Routes in Appendix B for route location.

Sign

1. Border and oval color: Blue; R-10, G-71, B-157
2. Internal color: White; R-255, G-255, B-255

Sign Content

1. Text

- A. Top line reads “Interurban/”, middle line reads “Burke Gilman”, and bottom line reads “Connector”
- B. First letter of each word capitalized, remaining letters lower case
- C. Font: Clearview Highway Type C, 2-inch cap height
- D. Color: White; R-255, G-255, B-255
- E. Alignment: Centered

2. Symbols

- A. Bicycle symbol, sized as noted in Figure 14. The bicycle symbol is always oriented to point to the left edge of the sign.
- B. Pedestrian symbol, sized as noted in Figure 14. The pedestrian symbol is always oriented to point to the left edge of sign.
- C. Symbol order when arrow points left, from left to right, bicycle - pedestrian
- D. Symbol order when arrow points right, from left to right, pedestrian - bicycle
- E. Symbol order when there is a double arrow, from left to right, bicycle - pedestrian
- F. See section 3.1-3 for symbols.
- G. Color: White; R-255, G-255, B-255

Organization of Signs within a Sign Assembly

1. The sign is located above Sign Types D2 and D3, but, when applicable, will be located below Sign Types C and B1.

Sign Placement

1. 30'-60' before an intersection between signed street routes and specified Interurban/Burke Gilman Connector routes.
2. Sign Location
 - A. 5' minimum setback from driveways

Sign Type E
Connector Sign, 18" x 24"

Clearview Highway Type C, 2" caps
1.5" radius, 0.5" border

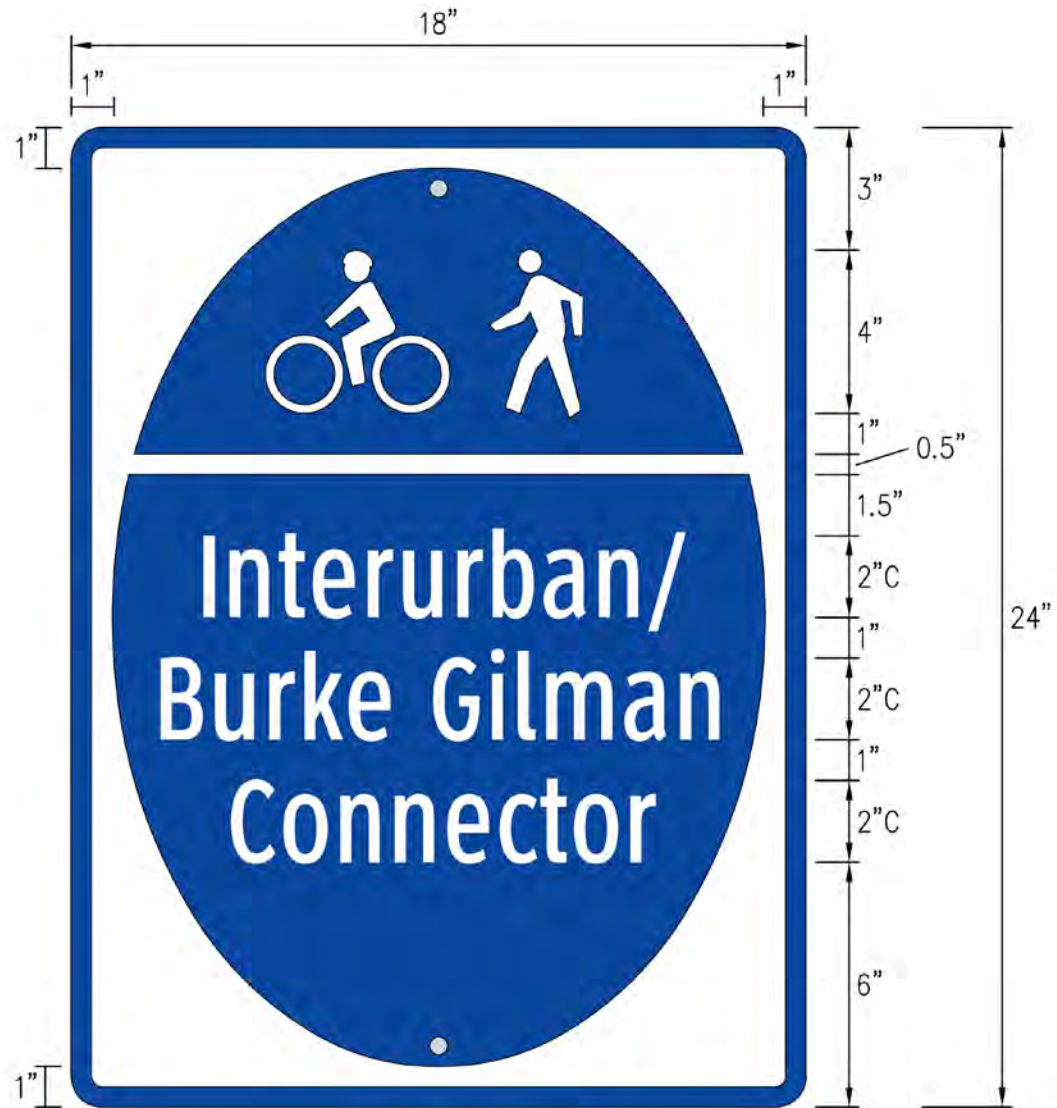

Figure 14: Connector Sign

3.3 INSTALLATION SPECIFICATIONS

Post Height

For post and sign height, different standards apply for trails and roadways. Figure 15 illustrates optimal sign height assemblies on freestanding posts along roadways and trails whereas Table 3 establishes guidelines for post height in different situations. In cases where right-of-way space is limited, vertical clearances become crucial for pedestrian safety (i.e. signs placed on the sidewalk). All city wayfinding signs are to adhere to these heights, in addition to sign height standards for signs in the right-of-way (see section 3.4), for adequate lateral clearance and system uniformity. If sign assemblies include signs of different sizes, sign post guidelines should apply to the bottom of the widest sign.

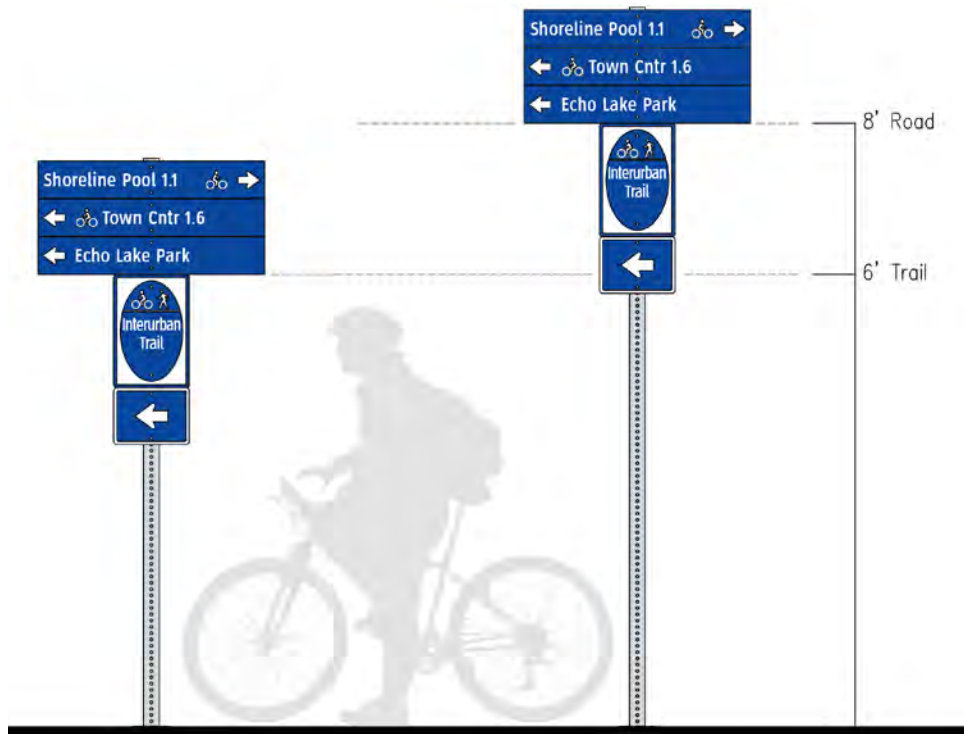

Figure 15: Sign Heights for Roadways and Trails

Vertical Clearance (from bottom of widest sign edge)				
	Trail	Sidewalk	Roadway	
	3' Lateral Clearance	0' Lateral Clearance	0'-3' Lateral Clearance	0'-3' Lateral Clearance
	6' Min.	8' Min.	8' Min.	8' Min.
Sign Type	6"	TS-7	TS-9	TS-9
	12"	TS-7	TS-9	TS-9
	18"	TS-8	TS-10	TS-10
	24"	TS-8	TS-10	TS-10

*Lateral clearances measured from nearest edge of sign to given surface.

Table 3: Sign Post Height based on AASHTO Vertical Clearances

Post Size and Materials

Three types of posts will be used for the wayfinding signing system. All post types will use the following fastening equipment: type 316 stainless steel fasteners; zinc plated fasteners with coating complying with ASTM B633, class Fe/Zn 5.

1. 3" diameter aluminum 6061-T6 post
 - A. Use for sign Type A, Interurban Trail Directional signs, only
 - B. Aluminum base used in combination with this post
2. 2.5" square Telespar Unistrut post
 - A. Use for sign Types B1, City Directional signs, only
 - B. Refer to the Shoreline Engineering Deveopment Manual (EDM) for standard details
3. 2" square Telespar Unistrut post
 - A. Use for sign Types C, D1, and E
 - B. Refer to the Shoreline Engineering Deveopment Manual (EDM) for standard details

Signs/Blades

Signs and sign blades follow the thickness specifications illustrated in Figure 16. The sign widths have been determined based on wind factors, sign size, and mounting style. Shoreline uses the following specifications/product types (per WSDOT specifications) to produce wayfinding signs:

- Material: Aluminum sheet metal plate, conforming to ASTM B209 alloy 6061-T6
- Reflective sheeting: Type II glass bead retroreflective sheeting

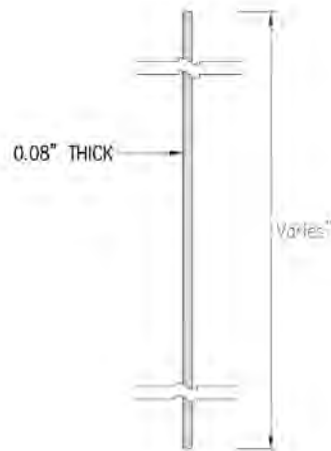

SIGN SECTION

NOTE: INCLUDES SIGN TYPES B2, C, D1, D2, D3, AND E.

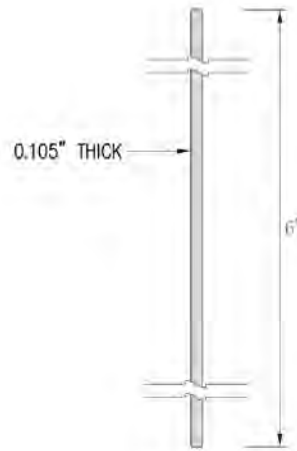

TYPE B1 SIGN SECTION



TYPE A SIGN SECTION

NOTE: INTERURBAN TRAIL DOUBLE-SIDE BLADE WILL BE SAME THICKNESS, BUT WILL BE CUSTOM SIZE, SEE FIGURE 4 FOR DETAILS.

Figure 16: Sign Blade Material Widths

3.4 SIGN PLACEMENT PRINCIPLES

The city wayfinding signing plan consists of points and paths. Points are the main feature of the system. They are locations where signs are placed for bicyclists to make a decision at the intersection of two signed bicycle routes. At these locations Type B1 signs will provide destination, directional arrows and distance information to allow bicyclists and pedestrians to make a decision to go toward major destinations throughout the city.

Paths are named trails or routes such as the Interurban Trail, Meridian Avenue North, and North 155th Street that require signage to guide cyclists along these on- and off-road routes. Type A and B1 signs will be provided along the paths for continued guidance towards a destination.

Sign Placement within the Right-of-Way

Following the Shoreline EDM, Shoreline Transportation Master Plan, MUTCD, and AASHTO guidelines, Table 4 and Figure 17 illustrate sign placement principles for signs located in the right-of-way and along shared-use paths. For additional standard clearances not listed in Table 4 see Shoreline EDM. Proper lateral placement of wayfinding signs allows for adequate visibility of the sign from the roadway, and it establishes proper spacing between sign edge and vehicles so that traffic does not damage the sign.

Along roadways, where urban elements (trees, furniture, etc.) influence sign location, placement should be based on the judgment of the designer/engineer. It is important to consider the amount of distance needed for a cyclist to read the sign and make a decision on direction as they approach an intersection.

Field Measurements

Identifying the exact placement of a sign is crucial to the effectiveness of the sign as well as preventing damages by vehicular traffic. When placing a sign in the field, follow sign placement principles such as measuring from centerlines, curblines, or back of sidewalk, respectively.

When locating new posts a spray mark (white) should be made on the surface (grass, concrete, etc.) illustrating the direction the sign will face and sign type.

Standard Lateral Clearances		
<i>From</i>	<i>To</i>	<i>Standard Clearance</i>
Curb Face	Closest part of any fixed object (excluding traffic control signs and parking meter posts)	2 feet
Edge of Sidewalk	Closest part of any fixed object (excluding traffic control signs and parking meter posts)	2 feet
Textured Surface of Wheelchair Ramp	Closest part of any fixed object (excluding traffic control signs and parking meter posts)	1 foot
Pole Face, Fire Hydrant	Closest part of any fixed object (excluding traffic control signs and parking meter posts)	5 feet
Multi-use Trail, Edge of Pavement	Closest part of any fixed object (excluding traffic control signs and parking meter posts)	2 feet (3 feet preferred)
Standard Vertical Clearances		
<i>From</i>	<i>To</i>	<i>Standard Clearance</i>
Sidewalk Surfaces	Any horizontal projection over named surface	8 feet
Bicycle Path Surfaces	Any horizontal projection over named surface	8 feet (trails) 10 feet (roadway)

Table 4: Standard Clearances for Signs in the Right-of-Way

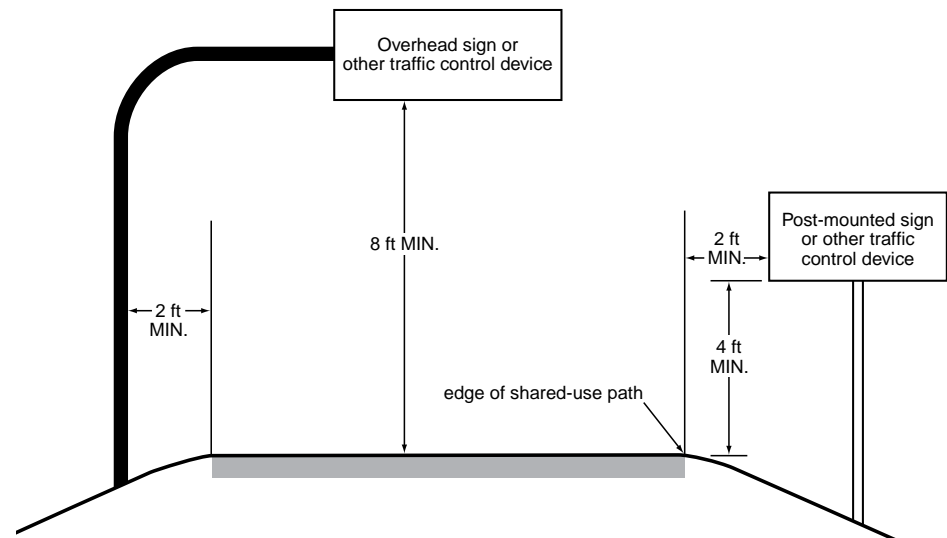

Figure 17: MUTCD Guidelines for Sign Placement on Shared-Use Paths

4.0 VEHICULAR SIGN STANDARDS

4.1 SIGN CONTENT

Vehicular wayfinding signs are currently in the early conceptual phase and will be implemented in the future. The signs have been modeled from an existing pilot vehicular wayfinding project at N 175th Street and Meridian Avenue N to fit with the pedestrian and bicyclist wayfinding signs.

4.1-1 Destinations

Destinations for vehicular wayfinding signs will be established in the future.

4.1-2 Symbols and Logos

Symbols and logos for vehicular wayfinding signs will be established in the future.

4.2 SIGN STANDARDS

Vehicular wayfinding signs are single-sided and are intended to direct and inform motorists of key destinations throughout the City. See Figure 18 for sign size specifications.

Sign

1. Border: White; R-255, G-255, B-255
2. Internal color: Blue; R-10, G-71, B-157

Sign Content

1. Text
 - A. First letter of each word capitalized, remaining letters lower case
 - B. Font: Clearview Highway Type C, 6-inch cap height
 - C. Color: White; R-255, G-255, B-255
 - D. Alignment: Justified Left
2. Destinations
 - A. There is a maximum of 3 destinations per sign.
3. Symbols and Logos
 - A. Shoreline Logo: featured in the top border of all vehicular signs
 - B. Single Arrow Symbol: one arrow symbol per destination
 1. For destinations left and straight ahead, arrow symbol justified left.
 2. For destinations right, arrow symbol justified right.

4.3 INSTALLATION SPECIFICATIONS

Installation specifications for vehicular wayfinding signs will be established in the future.

4.4 SIGN PLACEMENT PRINCIPLES

Sign placement principles for vehicular wayfinding signs will be established in the future.

Vehicular Wayfinding Sign
 Custom Size

Clearview Highway Type C, 6" caps
 1.5" radius, 0.75" border



Figure 18: Vehicular Wayfinding Sign

APPENDIX A: CITY REFERENCE MAPS

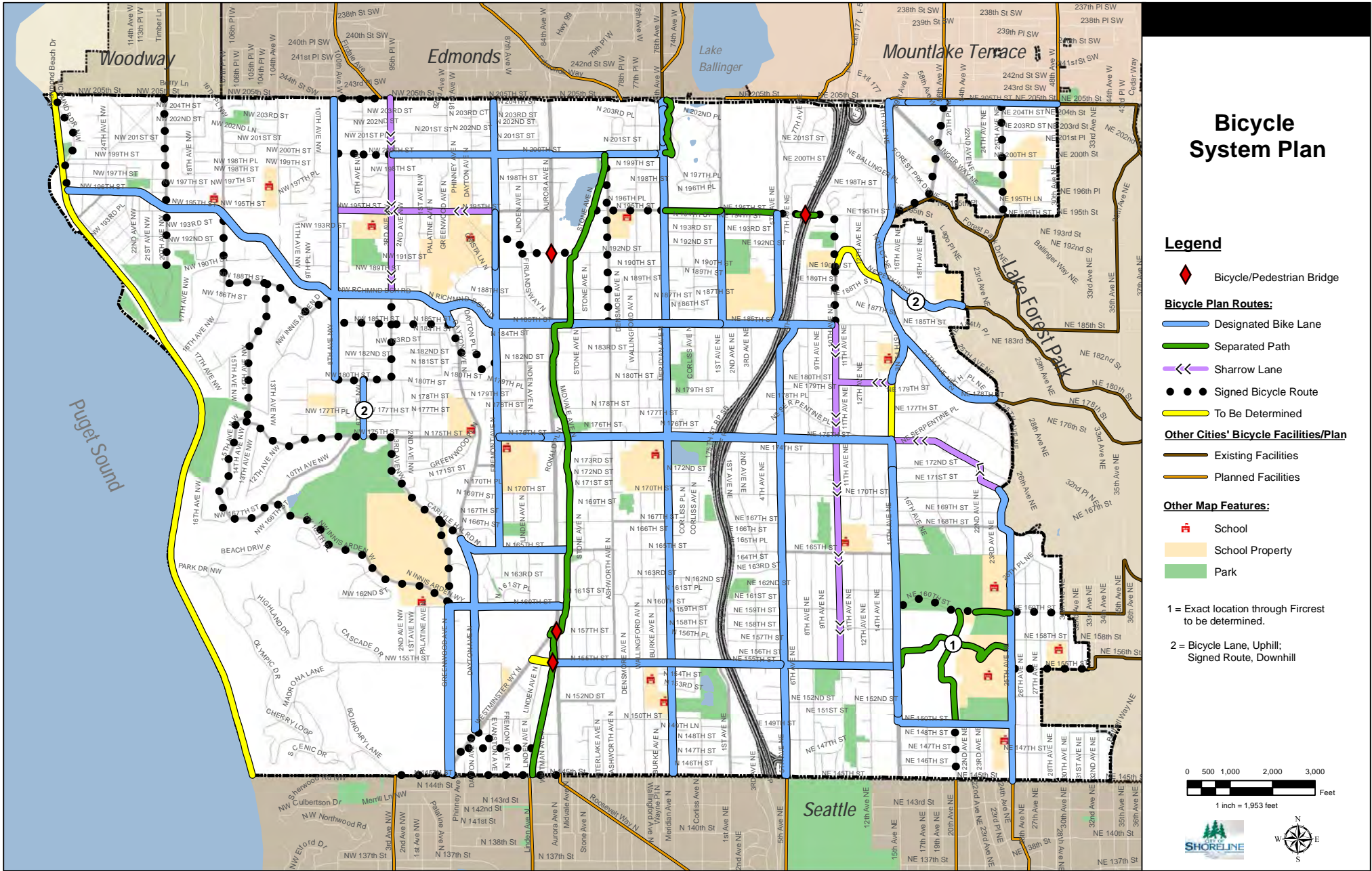

Figure 18: City Reference Map - Bicycle System Plan



APPENDIX A: CITY REFERENCE MAPS

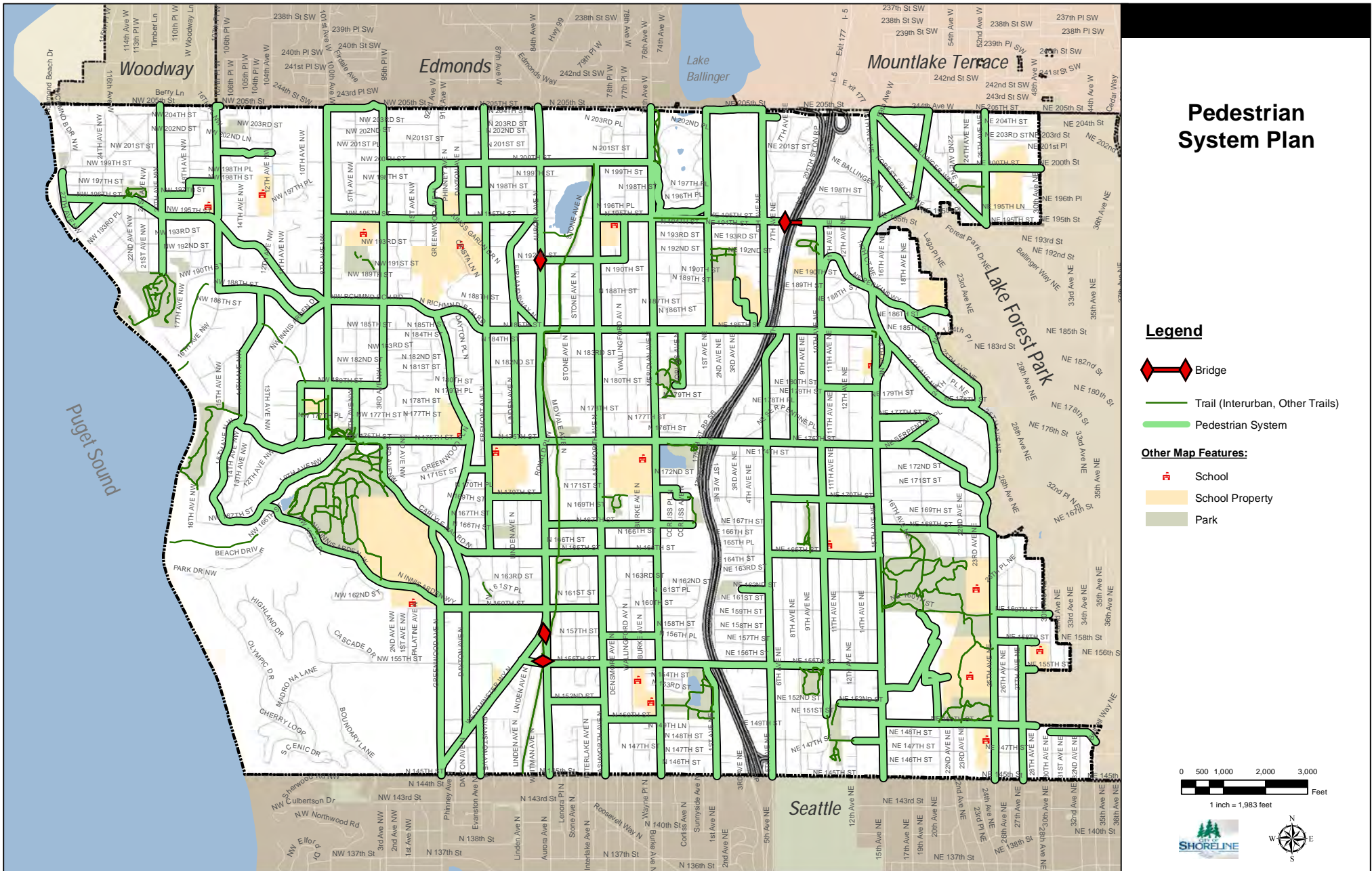

Figure 20: City Reference Map - Pedestrian System Plan

APPENDIX B: WAYFINDING SYSTEM PLAN AND MATRIX

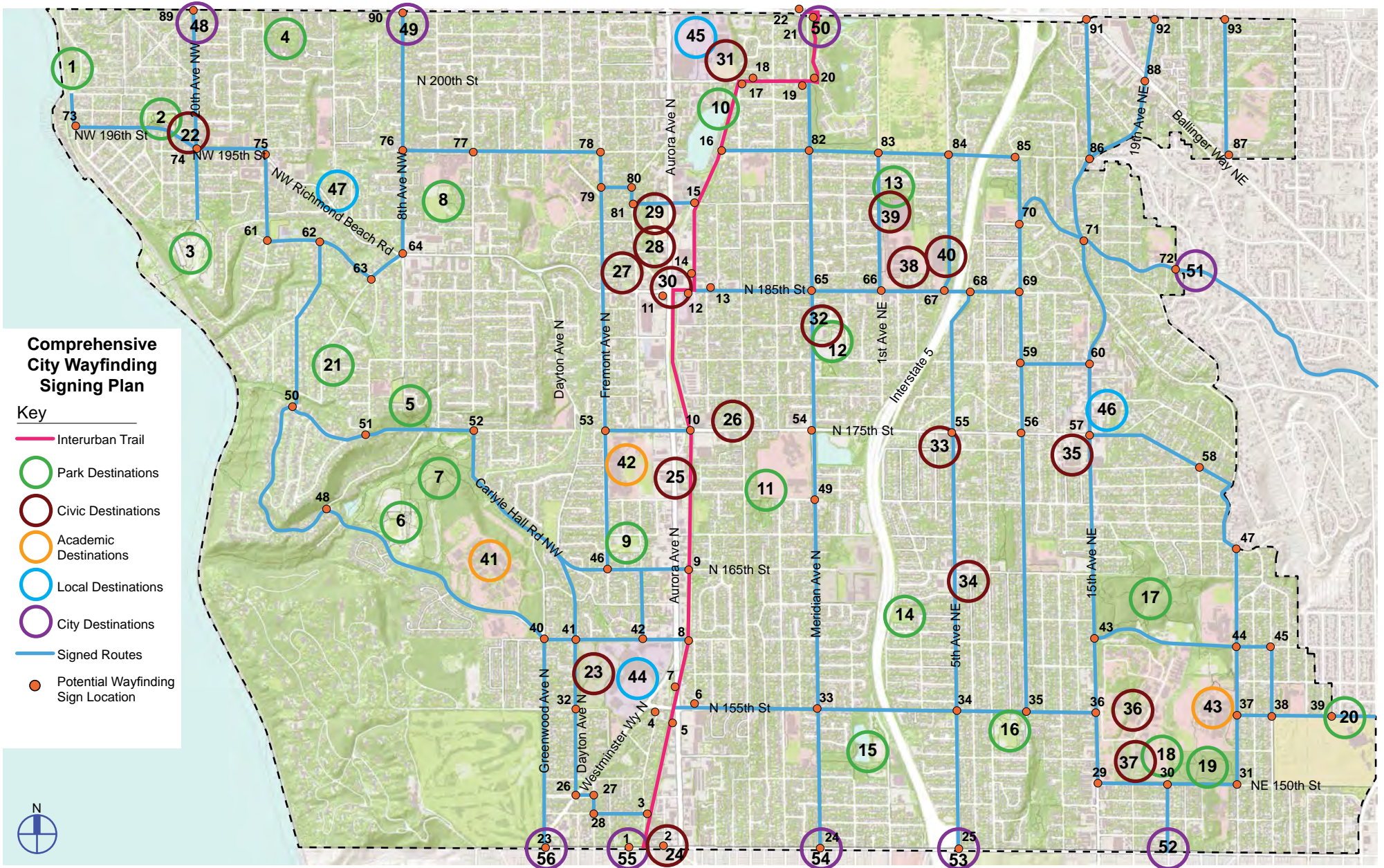

Figure 21: Comprehensive City Wayfinding Signing Plan



Sign Number	Location (Relative to Intersection)	Sign Facing	Destinations/Content	Sign Type	2- or 1-Sided	Distance (in miles)	Blade Count	Symbol	Comments
1	South side of N 145th Street, approximately 200' west of Interurban Trail.	W	N: Interurban Trail S: To Seattle, Interurban Trail	C, D2, D1, D3	1	N/A	N/A	N/A	Sign type C - To Seattle. Sign assembly order: C, D2 (pointing south), D1, D3.
2	North side of N 145th Street, equidistant between Interurban Trail and Whitman Avenue N.	E	N: Interurban Trail S: To Seattle, Interurban Trail	C, D2, D1, D3	1	N/A	N/A	N/A	Sign type C - To Seattle. Sign assembly order: C, D2 (pointing south), D1, D3.
3N	Northwest corner of trail intersection.	N	S: Seattle, Post Office W: WSDOT, Shoreline CC	A	2	N/A	4	Post Office	N/A
3S	Northwest corner of trail intersection.	S	N: Town Ctr, Hamlin Park, Aurora Square, Edmonds W: WSDOT, Shoreline CC	A	2	Town Ctr: 1.6 Hamlin Park: 2.4	6	N/A	N/A
4	South side of N 155th Street, equidistant between Linden Avenue N and Interurban Trail.	W	N: Town Ctr, Shoreview Park E: Hamlin Park S: Seattle	B1, D1, D3	1	Town Ctr: 1.2 Shoreview Park: 1.6 Hamlin Park: 1.9	4	N/A	N/A
5N	Directly at Interurban Trail Split.	N	S: Seattle, Post Office, WSDOT W: Aurora Square	A	2	N/A	4	Post Office	N/A
5S	Directly at Interurban Trail Split.	S	N: Town Ctr, Shoreview Park, Edmonds E: Hamlin Park, Burke Gilman Trail W: Aurora Square	A	2	Town Ctr: 1.3 Shoreview Park: 1.6 Hamlin Park: 2	6	N/A	N/A
6	Locate in lawn area (back of walk) on north side of N 155th Street at end of concrete retaining wall at Chevron. Intersection with Aurora Avenue N.	E	N: Town Ctr, Shoreview Park S: Seattle	B1, D1, D3	1	Town Ctr: 1.2 Shoreview Park: 1.6	3	N/A	Located at back of walk to funnel cyclists and pedestrians on sidewalk/crosswalk.
7N	Directly at Interurban Trail Split.	N	E: Hamlin Park, Burke Gilman Trail, Twin Ponds Park S: Seattle, Post Office W: Aurora Square	A	2	Hamlin Park: 2	6	Post Office	N/A
7S	Directly at Interurban Trail Split.	S	N: Town Ctr, Shoreview Park, Edmonds, Richmond Highlands Rec, Richmond Beach, Shoreline CC	A	2	Town Ctr: 1.1 Shoreview Park: 1.5 Richmond Beach: 3.9	6	N/A	N/A
8N	Southeast corner of Interurban Trail and N 160th Street intersection.	N	S: Seattle, Aurora Square W: Shoreline CC, Shoreview Park, Richmond Beach	A	2	Shoreview Park: 1.1 Richmond Beach: 3.6	6	N/A	N/A
8S	Southeast corner of Interurban Trail and N 160th Street intersection.	S	N: Town Ctr, Edmonds, Richmond Highlands Rec W: Shoreline CC, Shoreview Park, Richmond Beach	A	2	Town Ctr: 0.8 Shoreview Park: 1.1 Richmond Beach: 3.6	6	N/A	N/A

Table 5: City Wayfinding Signing Matrix

Sign Number	Location (Relative to Intersection)	Sign Facing	Destinations/Content	Sign Type	2- or 1-Sided	Distance (in miles)	Blade Count	Symbol	Comments
9N	Southwest corner of Interurban Trail and N 165th Street intersection.	N	S: Seattle, Aurora Square, Richmond Beach, Shoreview Park W: Richmond Highlands Rec, Shorewood HS	A	2	Shorewood HS: 0.8 Richmond Beach: 3.8	6	N/A	N/A
9S	Southwest corner of Interurban Trail and N 165th Street intersection.	S	N: Town Ctr, City Hall, Edmonds, Police Station W: Richmond Highlands Rec, Shorewood HS	A	2	City Hall: 0.5 Town Ctr: 0.6 Shorewood HS: 0.8	6	Police	N/A
10N	Southwest corner of Interurban Trail and N 175th Street intersection, in planter.	N	E: City Hall S: Aurora Square, Richmond Highlands Rec, Seattle, Richmond Beach W: Shorewood HS	A	2	City Hall: 0.1 Shorewood HS: 0.3	6	Police	N/A
10S	Southwest corner of Interurban Trail and N 175th Street intersection, in planter.	S	N: Police Station, Dept of Licensing, Echo Lake Park, Edmonds E: City Hall W: Shorewood HS	A	2	City Hall: 0.1 Shorewood HS: 0.3	6	Police	N/A
11	South side of N 185th Street, approximately 200' west of Aurora Avenue N.	W	N: Richmond Beach E: Shoreline Stadium and Pool, Spartan Rec Ctr S: Town Ctr, City Hall	B1, D1, D3	1	City Hall: 0.7 Town Ctr: 0.8 Spartan Rec Ctr: 0.8 Shoreline Stadium: 1 Shoreline Pool: 1.1 Richmond Beach: 3.2	6	N/A	N/A
12E	Southwest corner of Midvale Avenue N and N 185th Street.	E	N: Echo Lake Park W: City Hall, Town Ctr, Shorewood HS, Richmond Highlands Rec, Seattle	A, D1	2	City Hall: 0.6 Town Ctr: 0.6 Shorewood HS: 0.9	6	N/A	N/A
12W	Southwest corner of Midvale Avenue N and N 185th Street.	W	N: Echo Lake Park, Edmonds E: Police Station, Shoreline Stadium and Pool, Spartan Rec Ctr	A, D1	2	Spartan Rec Ctr: 0.8 Shoreline Stadium: 1 Shoreline Pool: 1.1	6	Police	N/A
13	North side of N 185th Street, equidistant between Midvale Avenue N and Stone Avenue N.	E	N: Richmond Beach, Echo Lake Park W: Town Ctr, Police Station	B1, D1, D3	1	Town Ctr: 0.7 Richmond Beach: 3.2	4	Police	N/A
14N	West side of Interurban Trail, approximately 200' north of N 185th Street.	N	E: Police Station, Shoreline Stadium, Spartan Rec Ctr S: Town Ctr, Seattle, Police Station	A	2	Town Ctr: 0.8 Spartan Rec Ctr: 1.2 Shoreline Stadium: 1.3	5	Police	N/A
14S	West side of Interurban Trail, approximately 200' north of N 185th Street.	S	N: Echo Lake Park, Edmonds, Shoreline Park-n-Ride, Transit Ctr, Shoreline Park	A	2	N/A	5	Transit	N/A
15N	Northwest corner of Interurban Trail and 192nd Street intersection.	N	S: Town Ctr, Police Station, Seattle W: Richmond Beach, Shoreline Park-n-Ride	A	2	Town Ctr: 1 Richmond Beach: 2.8	5	Police Tranist	N/A

Table 5: City Wayfinding Signing Matrix



Sign Number	Location (Relative to Intersection)	Sign Facing	Destinations/Content	Sign Type	2- or 1-Sided	Distance (in miles)	Blade Count	Symbol	Comments
15S	Northwest corner of Interurban Trail and 192nd Street intersection.	S	N: Echo Lake Park, Transit Ctr, Edmonds, Shoreline Park W: Richmond Beach, Shoreline Park-n-Ride	A	2	Richmond Beach: 2.8	6	Transit	N/A
16N	Southeast corner of Interurban Trail and N 195th Street intersection.	N	E: Shoreline Park, Shoreline Pool, Spartan Rec Ctr, Burke Gilman Trail S: Town Ctr, Seattle	A	2	Shoreline Pool: 0.9 Spartan Rec Ctr: 1.1 Town Ctr: 1.2	6	N/A	N/A
16S	Southeast corner of Interurban Trail and N 195th Street intersection.	S	N: Edmonds, Echo Lake Park, Transit Ctr E: Shoreline Park, Shoreline Pool, Burke Gilman Trail	A	2	Shoreline Pool: 0.9 Spartan Rec Ctr: 1.1	6	Transit	N/A
17N	Southwest corner of Ashworth Avenue N and N 200th Street, at Interurban Trailhead/Echo Lake Park Entrance.	N	S: Seattle, Burke Gilman Trail, Shoreline Park, Shoreline Pool, Town Ctr	A	5	Shoreline Pool: 1 Town Ctr: 1.4	4	N/A	N/A
17S	Southwest corner of Ashworth Avenue N and N 200th Street, at Interurban Trailhead/Echo Lake Park Entrance.	S	N: Transit Ctr, Aurora Village E: Interurban Trail, Edmonds	A	4	N/A	4	Transit	N/A
18	North side of N 200th Street between Ashworth Avenue N and Wallingford Avenue North.	E	W: Interurban Trail	D1, D2	1	N/A	N/A	N/A	D2 points south.
19N	West side of Meridian Avenue N, 30' north of N 200th Street.	N	W: Interurban Trail	D1, D2	1	N/A	N/A	N/A	D2 points west.
19S	South side of N 200th Street between Burke Avenue N and Meridian Avenue North.	W	E: Interurban Trail	D1, D2	1	N/A	N/A	N/A	D2 points east.
20	Northeast corner of Meridian Avenue N and N 200th Street intersection, at adjoining corner of Interurban Trail and sidewalk.	N	W: Interurban Trail	D1, D2	1	N/A	N/A	N/A	N/A
21E	Southeast corner of Meridian Avenue N and N 205th Street intersection, at Interurban Trail trailhead.	E	S: Interurban Trail, Town Ctr, Seattle, Echo Lake Park	A	2	Town Ctr: 2.1	4	N/A	N/A
21W	Southeast corner of Meridian Avenue N and N 205th Street intersection, at Interurban Trail trailhead.	W	N: Interurban Trail, Edmonds, Lynnwood, Mountlake Terrace	A	2	N/A	4	N/A	N/A
22	Northwest corner of Meridian Avenue N and N 205th Street intersection.	N	S: Interurban Trail	D1, D2	1	N/A	N/A	N/A	N/A
23N	West side of Greenwood Avenue N, 30' north of N 145th Street.	N	S: To Seattle	C	1	NA	N/A	N/A	N/A
23S	East side of Greenwood Avenue N, 30' south of N 145th Street.	S	N: Aurora Square, Shoreline CC, Shoreview Park, Edmonds	B1, B2	1	Shoreview Park: 1.5	4	N/A	Not in City limits.

Table 5: City Wayfinding Signing Matrix

Sign Number	Location (Relative to Intersection)	Sign Facing	Destinations/Content	Sign Type	2- or 1-Sided	Distance (in miles)	Blade Count	Symbol	Comments
24N	West side of Meridian Avenue N, 30' north of N 145th Street.	N	S: To Seattle	C	1	N/A	N/A	N/A	N/A
24S	East side of Meridian Avenue N, 30' south of N 145th Street.	S	N: Town Ctr, Shoreline Pool, Spartan Rec Ctr, Hamlin Park, Meridian Park Field, Twin Ponds Park	B1, B2	1	Hamlin Park: 1.9 Town Ctr: 2.7 Spartan Rec Ctr: 2.5 Shorline Pool: 2.6	6	N/A	Not in City limits.
25N	West side of 5th Avenue NE, 30' north of N 145th Street.	N	S: To Pinehurst/Northgate	C	1	N/A	N/A	N/A	N/A
25S	East side of 5th Avenue NE, 30' south of N 145th Street.	S	N: Town Ctr, Shoreline Stadium and Pool, Spartan Rec Ctr, Hamlin Park, Shoreline Library	B1, B2	1	Hamlin Park: 1.5 Town Ctr: 2.6 Spartan Rec Ctr: 2.4 Shoreline Stadium: 2.2 Shorline Pool: 2.7	6	Library	Not in City limits.
26N	West side of Dayton Avenue N, 30' north of N 149th Street (westbound travel lane).	N	E: Interurban Trail, Seattle, Hamlin Park	B1	1	Interurban Trail: 0.3 Hamlin Park: 2.7	3	N/A	N/A
26E	North side of N 149th Street (westbound travel lane), 30' east of Westminster Way N.	E	N: Shoreview Park, WSDOT, Shoreline CC	B1	1	Shoreview Park: 1.4	3	N/A	N/A
27S	East side of Evanston Avenue N, 30' south of N 149th Street (eastbound travel lane).	S	W: Shoreview Park, WSDOT, Shoreline CC	B1	1	Shoreview Park: 1.4	3	N/A	N/A
27W	South side of N 149th Street (eastbound travel lane), 30' west of Evanston Avenue N.	W	S: Interurban Trail, Seattle, Hamlin Park	B1	1	Interurban Trail: 0.3 Hamlin Park: 2.7	3	N/A	N/A
28N	West side of Evanston Avenue N, 30' north of N 148th Street.	N	E: Interurban Trail, Seattle, Hamlin Park	B1	1	Interurban Trail: 0.2 Hamlin Park: 2.6	3	N/A	N/A
28E	North side of N 148th Street, 30' east of Evanston Avenue N.	E	N: Shoreview Park, WSDOT, Shoreline CC	B1	1	Shoreview Park: 1.5	3	N/A	N/A
29N	West side of 15th Avenue NE, 30' north of NE 150th Street.	N	E: South Woods, Shorecrest HS, Burke Gilman Trail, Hamlin Park	B1, E, D2	1	Shorecrest HS: 0.7 Hamlin Park: 1.4	4	N/A	D2 arrow points east.
29E	North side of NE 150th Street, 30' east of 15th Avenue NE.	E	N: Hamlin Park, Town Ctr, North City, Paramount School Park, Interurban Trail	B1, E, D2	1	Hamlin Park: 0.7 Town Ctr: 2.8	5	N/A	D2 arrow points north.
30E	North side of NE 150th Street, 30' east of 20th Avenue NE.	E	N: Off Leash Dog Park S: To Olympic Hills W: Interurban Trail, Paramount School Park	B1	1	N/A	4	N/A	N/A
30W	South side of NE 150th Street, 30' west of 20th Avenue NE.	W	N: Off Leash Dog Park E: Shorecrest HS, Burke Gilman Trail S: To Olympic Hills	B1	1	Shorecrest HS: 0.5	4	N/A	N/A

Table 5: City Wayfinding Signing Matrix



Sign Number	Location (Relative to Intersection)	Sign Facing	Destinations/Content	Sign Type	2- or 1-Sided	Distance (in miles)	Blade Count	Symbol	Comments
31N	West side of 25th Avenue NE, 30' north of NE 150th Street.	N	W: Town Ctr, North City, Paramount School Park, Interurban Trail	B1, E, D2	1	Town Ctr: 3.3	5	N/A	D2 arrow points west.
31W	South side of NE 150th Street, 30' west of 25th Avenue NE.	W	N: Hamlin Park, Shorecrest HS, Burke Gilman Trail	B1, E, D2	1	Shorecrest HS: 0.3 Hamlin Park: 0.9	3	N/A	D2 arrow points north.
32N	West side of Dayton Avenue N, 30' north of N 155th Street.	N	S: Interurban Trail, Seattle, Hamlin Park	B1	1	Hamlin Park: 3.2	3	N/A	N/A
32S	East side of Dayton Avenue N, 30' south of N 155th Street.	S	N: Shoreview Park, WSDOT, Shoreline CC	B1	1	Shoreview Park: 1.1	3	N/A	N/A
33N	West side of Meridian Avenue N, 30' north of N 155th Street.	N	E: Hamlin Park, Burke Gilman Trail S: Seattle W: Interurban Trail	B1, E, D3	1	Hamlin Park : 1.4	4	N/A	N/A
33E	North side of N 155th Street, 30' east of Meridian Avenue N.	E	N: Shoreline Stadium and Pool, Spartan Rec Ctr S: Seattle W: Town Ctr, Interurban Trail	B1, E, D3	1	Interurban Trail: 0.5 Shoreline Pool: 2.1 Spartan Rec Ctr: 1.9 Shoreline Stadium: 2 Town Ctr: 1.7	6	N/A	Sign E and D3 mounted parallel to roadway.
33S	East side of Meridian Avenue N, 30' south of N 155th Street.	S	N: Shoreline Stadium and Pool, Spartan Rec Ctr E: Hamlin Park, Burke Gilman Trail W: Interurban Trail	B1, E, D3	1	Shoreline Pool: 2 Spartan Rec Ctr: 1.9 Shoreline Stadium: 2 Hamlin Park : 1.4	6	N/A	N/A
33W	South side of N 155th Street, 30' west of Meridian Avenue N.	W	N: Shoreline Pool, Spartan Rec Ctr S: Seattle E: Hamlin Park, Burke Gilman Trail, Twin Ponds Park	B1, E, D3	1	Shoreline Pool: 2 Spartan Rec Ctr: 1.9 Hamlin Park : 1.4	6	N/A	Sign E and D3 mounted parallel to roadway.
34N	West side of 5th Avenue NE, 30' north of NE 155th Street.	N	E: Hamlin Park, Burke Gilman Trail S: Pinehurst/Northgate W: Interurban Trail, Town Ctr	B1, E, D3	1	Hamlin Park: 0.9 Town Ctr: 2.2	5	N/A	N/A
34E	North side of NE 155th Street, 30' east of 5th Avenue NE.	E	N: Shoreline Stadium and Pool, Library S: Pinehurst/Northgate W: Town Ctr, Interurban Trail	B1, E, D3	1	Shoreline Pool: 2.1 Shoreline Stadium: 1.8 Town Ctr: 2.2	6	Library	Sign E and D3 mounted parallel to roadway.
34S	East side of 5th Avenue NE, 30' south of NE 155th Street.	S	N: Shoreline Stadium and Pool, Library E: Hamlin Park, Burke Gilman Trail W: Interurban Trail	B1, E, D3	1	Shoreline Pool: 2.1 Shoreline Stadium: 1.8 Hamlin Park : 0.9	6	Library	N/A
34W	South side of NE 155th Street, 30' west of 5th Avenue NE.	W	N: Shoreline Stadium and Pool, Library S: Pinehurst/Northgate E: Hamlin Park, Burke Gilman Trail	B1, E, D3	1	Shoreline Pool: 2.1 Shoreline Stadium: 1.8 Hamlin Park : 0.9	6	Library	Sign E and D3 mounted parallel to roadway.
35N	West side of 10th Avenue NE, 30' north of NE 155th Street.	N	E: Hamlin Park, Burke Gilman Trail, South Woods W: Interurban Trail, Twin Ponds Park	B1, E, D3	1	Hamlin Park: 0.7	5	N/A	N/A

Table 5: City Wayfinding Signing Matrix

Sign Number	Location (Relative to Intersection)	Sign Facing	Destinations/Content	Sign Type	2- or 1-Sided	Distance (in miles)	Blade Count	Symbol	Comments
35E	North side of NE 155th Street, 30' east of 10th Avenue NE.	E	W: Twin Ponds Park, Shoreline Stadium and Pool, Spartan Rec Ctr, Town Ctr, Interurban Trail	B1, E, D3	1	Shoreline Pool: 2.4 Spartan Rec Ctr: 2.1 Shoreline Stadium: 2 Town Ctr: 2.4	6	N/A	Sign E and D3 mounted parallel to roadway.
35W	South side of NE 155th Street, 30' west of 10th Avenue NE.	W	E: Hamlin Park, South Woods, Burke Gilman Trail	B1, E, D3	1	Hamlin Park: 0.7	3	N/A	Sign E and D3 mounted parallel to roadway.
36N	West side of 15th Avenue NE, 30' north of NE 155th Street.	N	S: South Woods, Burke Gilman Trail W: Town Ctr, Interurban Trail, Paramount School Park	B1, E, D3	1	Town Ctr: 2.7	5	N/A	N/A
36S	East side of 15th Avenue NE, 30' south of NE 155th Street.	S	N: Hamlin Park, Post Office, North City W: Town Ctr, Paramount School Park, Interurban Trail	B1, E, D2	1	Hamlin Park: 0.4 Town Ctr: 2.7	6	Post Office	D2 arrow points west.
36W	South side of NE 155th Street, 30' west of 15th Avenue NE.	W	N: Hamlin Park, Post Office, North City S: Burke Gilman Trail, South Woods, Shorecrest HS	B1, E, D2	1	Hamlin Park: 0.4 Shorecrest HS: 1	6	Post Office	D2 arrow points south.
37N	West side of 25th Avenue NE, 30' north of NE 155th Street.	N	E: Burke Gilman Trail S: South Woods, Interurban Trail, Town Ctr, Paramount School Park	B1, E, D3	1	Town Ctr: 3.7	5	N/A	N/A
37E	North side of NE 155th Street, 30' east of 25th Avenue NE.	E	N: Hamlin Park, North City, Post Office S: Town Ctr, Paramount School Park, Interurban Trail	B1, E, D2	1	Hamlin Park: 0.7 Town Ctr: 3.7	6	Post Office	D2 arrow points south.
37S	East side of 25th Avenue NE, 30' south of NE 155th Street.	S	N: Hamlin Park, North City, Post Office E: Burke Gilman Trail	B1, E, D2	1	Hamlin Park: 0.7	4	Post Office	D2 arrow points east.
38N	West side of 27th Avenue NE, 30' north of NE 155th Street.	N	E: Burke Gilman Trail W: Shorecrest HS, Hamlin Park, Interurban Trail	B1, E, D3	1	Shorecrest HS: 0.2 Hamlin Park: 0.7	4	N/A	N/A
38E	North side of NE 155th Street, 30' east of 27th Avenue NE.	E	W: Hamlin Park, South Woods, Town Ctr, Shorecrest HS, Interurban Trail	B1, E, D3	1	Shorecrest HS: 0.2 Hamlin Park: 0.8 Town Ctr: 3.8	5	N/A	Sign E and D3 mounted parallel to roadway.
38W	South side of NE 155th Street, 30' west of 27th Avenue NE.	W	E: Lake Forest Park, Burke Gilman Trail	B1, E, D3	1	N/A	2	N/A	Sign E and D3 mounted parallel to roadway.
39E	North side of NE 155th Street at Shoreline city limits, midblock between 32nd Avenue NE and 33rd Avenue NE.	E	W: Hamlin Park, South Woods, Town Ctr, Shorecrest HS, Interurban Trail	B1, B2, E, D3	1	Shorecrest HS: 0.4 Hamlin Park: 1 Town Ctr: 4	4	N/A	N/A
39W	South side of NE 155th Street at Shoreline city limits, midblock between 32nd Avenue NE and 33rd Avenue NE.	W	E: Burke Gilman Trail, To Lake Forest Park	B1, C, E, D3	1	N/A	1	N/A	Sign C reads - To Lake Forest Park.
40E	North side of N 160th Street, 30' east of Greenwood Avenue N.	E	N: Shoreview Park, Richmond Beach, Boeing Creek Park, Shoreline CC, Edmonds S: Seattle	B1	1	Shoreview Park: 0.7 Richmond Beach: 3.1	6	N/A	N/A

Table 5: City Wayfinding Signing Matrix



Sign Number	Location (Relative to Intersection)	Sign Facing	Destinations/Content	Sign Type	2- or 1-Sided	Distance (in miles)	Blade Count	Symbol	Comments
40W	South side of NW Innis Arden Way, 30' west of Greenwood Avenue N.	W	E: Hamlin Park, Interurban Trail, Town Ctr, Richmond Highlands Rec S: Seattle	B1	1	Interurban Trail: 0.5 Hamlin Park: 2.8 Town Ctr: 1.4	5	N/A	N/A
41N	West side of Dayton Avenue N, 30' north of N 160th Street.	N	E: Town Ctr, Interurban Trail S: WSDOT W: Shoreview Park, Shoreline CC	B1	1	Interurban Trail: 0.4 Town Ctr: 1.2 Shoreview Park: 0.8	5	N/A	N/A
41E	North side of N 160th Street, 30' east of Dayton Avenue N.	E	S: WSDOT W: Shoreview Park, Richmond Beach, Boeing Creek Park and Open Space, Shoreline CC	B1	1	Shoreview Park: 0.8 Richmond Beach: 3.2	6	N/A	N/A
41S	East side of Dayton Avenue N, 30' south of N 160th Street.	S	E: Hamlin Park, Town Ctr, Interurban Trail, Richmond Highlands Rec W: Shoreview Park, Richmond Beach	B1	1	Interurban Trail: 0.4 Hamlin Park: 2.7 Town Ctr: 1.2 Shoreview Park: 0.8 Richmond Beach: 3.2	6	N/A	N/A
41W	South side of N 160th Street, 30' west of Dayton Avenue N.	W	E: Hamlin Park, Interurban Trail, Town Ctr, Richmond Highlands Rec S: WSDOT	B1	1	Interurban Trail: 0.4 Hamlin Park: 2.7 Town Ctr: 1.2	5	N/A	N/A
42E	North side of N 160th Street, 30' east of Linden Avenue N.	E	N: Richmond Highlands Rec W: Shoreview Park, Richmond Beach, Boeing Creek Park, Shoreline CC	B1	1	Shoreview Park: 1.1 Richmond Beach: 3.4	5	N/A	N/A
42W	South side of N 160th Street, 30' west of Linden Avenue N.	W	N: Richmond Highlands Rec E: Interurban Trail, Town Ctr, Hamlin Park	B1	1	Interurban Trail: 0.2 Hamlin Park: 2.5 Town Ctr: 1	4	N/A	N/A
43E	North side of NE 160th Street, 30' east of 15th Avenue NE.	E	N: North City, Post Office S: Interurban Trail, Town Ctr, Paramount School Park	B1	1	Town Ctr: 3	5	Post Office	N/A
43S	East side of 15th Avenue NE, 30' south of NE 160th Street.	S	N: North City, Post Office E: Burke Gilman Trail, Shorecrest HS	B1	1	Shorecrest HS: 0.9	4	Post Office	N/A
44S	East side of 25th Avenue NE, 30' south of NE 160th Street.	S	W: Town Ctr, Interurban Trail, North City, Post Office, Paramount School Park, Hamlin Park	B1	1	Hamlin Park: 0.3 Town Ctr: 3.5	6	Post Office	N/A
44W	West side of 25th Avenue NE, in landscape bed directly south of Hamlin Park entrance drive at NE 160th Street.	W	S: South Woods, Shorecrest HS, Burke Gilman Trail	B1	1	Shorecrest HS: 0.3	4	N/A	N/A
45S	East side of 27th Avenue NE, 30' south of NE 160th Street.	S	W: Hamlin Park, Town Ctr, Interurban Trail, North City, Post Office	B1	1	Hamlin Park: 0.5 Town Ctr: 3.7	5	Post Office	N/A
45W	South side of NE 160th Street, 30' west of 27th Avenue NE.	W	S: Burke Gilman Trail, South Woods, Shorecrest HS, Burke Gilman Trail	B1	1	Shorecrest HS: 0.4	4	N/A	N/A
46N	West side of Fremont Avenue N, 30' north of N 165th Street.	N	E: Town Ctr, Interurban Trail W: Shoreview Park, Richmond Beach, Boeing Creek Park and Open Space	B1	1	Interurban Trail: 0.3 Town Ctr: 0.9 Richmond Beach: 2.9	6	N/A	N/A

Table 5: City Wayfinding Signing Matrix

Sign Number	Location (Relative to Intersection)	Sign Facing	Destinations/Content	Sign Type	2- or 1-Sided	Distance (in miles)	Blade Count	Symbol	Comments
46E	North side of N 165th Street, 30' east of Fremont Avenue N.	E	N: Richmond Highlands Rec, Shorewood HS W: Shoreview Park, Richmond Beach, Boeing Creek Park	B1	1	Shorewood HS: 0.5 Shoreview Park: 1.4 Richmond Beach: 2.9	5	N/A	N/A
46W	South side of N 165th Street, 30' west of Fremont Avenue N.	W	N: Richmond Highlands Rec, Shorewood HS E: Town Ctr, Interurban Trail	B1	1	Interurban Trail: 0.3 Shorewood HS: 0.5 Town Ctr: 0.9	4	N/A	N/A
47N	South side of NE 168th Street, 30' west of 25th Avenue NE.	N	S: Hamlin Park, Shorecrest HS, South Woods, Burke Gilman Trail, Interurban Trail	B1	1	Shorecrest HS: 0.8 Hamlin Park: 0.8	5	N/A	N/A
47S	East side of 25th Avenue NE, 30' south of NE 168th Street.	S	N: North City, Post Office	B1	1	N/A	2	Post Office	N/A
48E	North side of NW Innis Arden Way, 30' east of 10th Avenue NW.	E	W: Richmond Beach, Edmonds	B1	1	Richmond Beach: 2.1	2	N/A	N/A
48S	East side of NW 167th Street, 30' south of NW Innis Arden Way.	S	E: Interurban Trail, Town Ctr, Richmond Highlands Rec S: Seattle, Shoreline CC, Shoreview Park	B1	1	Shoreview Park: 0.3 Town Ctr: 2.3	6	N/A	N/A
49N	West side of Meridian Avenue N, 30' north of N 170th Street.	N	S: Hamlin Park, Interurban Trail, Twin Ponds Park, Seattle	B1	1	Hamlin Park: 2.2	4	N/A	N/A
49S	East side of Meridian Avenue N, 30' south of N 170th Street.	S	N: King County Court, Cromwell Park, Shoreline Stadium and Pool, Spartan Rec Ctr	B1	1	Spartan Rec Ctr: 1.2 Shoreline Stadium: 1.3 Shoreline Pool: 1.3	5	N/A	N/A
50N	West side of 14th Avenue NW, 30' north of NW 175th Street.	N	E: Richmond Highlands Rec, Town Ctr, Interurban Trail, Boeing Creek Park S: Shoreview Park, Seattle	B1	1	Town Ctr: 2.4 Shoreview Park: 1	6	N/A	N/A
50E	North side of NW 175th Street, 30' east of 14th Avenue NW.	E	N: Richmond Beach, Edmonds S: Shoreview Park	B1	1	Richmond Beach: 1.4 Shoreview Park: 1	3	N/A	N/A
50S	East side of 15th Avenue NW, 30' south of NW 175th Street.	S	N: Richmond Beach, Edmonds E: Richmond Highlands Rec, Town Ctr, Interurban Trail, Boeing Creek Park	B1	1	Richmond Beach: 1.4 Town Ctr: 2.4	6	N/A	N/A
51E	North side of NW 175th Street, 30' east of 10th Avenue NW.	E	N: Sunset School Park W: Richmond Beach	B1	1	Richmond Beach: 1.6	2	N/A	N/A
51W	South side of NW 175th Street, 30' west of 10th Avenue NW.	W	N: Sunset School Park E: Richmond Highlands Rec, Town Ctr, Interurban Trail, Boeing Creek Park	B1	1	Town Ctr: 2.1	5	N/A	N/A
52S	West side of 3rd Avenue NW, 30' south of NW 175th Street.	S	W: Boeing Creek Open Space, Richmond Beach	B1	1	Richmond Beach: 2.1	2	N/A	N/A
52W	South side of NW 175th Street, 30' west of 3rd Avenue NW.	W	S: Richmond Highlands Rec, Town Ctr, Interurban Trail	B1	1	Town Ctr: 1.7	3	N/A	N/A

Table 5: City Wayfinding Signing Matrix



Sign Number	Location (Relative to Intersection)	Sign Facing	Destinations/Content	Sign Type	2- or 1-Sided	Distance (in miles)	Blade Count	Symbol	Comments
53N	West side of Fremont Avenue N, 30' north of N 175th Street.	N	E: City Hall, Town Ctr, Interurban Trail S: Richmond Highlands Rec	B1	1	City Hall: 0.3 Town Ctr: 0.2 Interurban Trail: 0.3	4	N/A	N/A
53E	North side of N 175th Street, 30' east of Fremont Avenue N.	E	N: Shoreline Park-n-Ride, Historical Museum, Dept of Licensing S: Richmond Highlands Rec	B1	1	N/A	4	Transit	N/A
53S	East side of Fremont Avenue N, 30' south of N 175th Street.	S	N: Shoreline Park-n-Ride, Historical Museum, Dept of Licensing E: City Hall, Town Ctr, Interurban Trail	B1	1	City Hall: 0.3 Town Ctr: 0.2 Interurban Trail: 0.3	6	Transit	N/A
54N	West side of Meridian Avenue N, 60' north of N 175th Street.	N	S: Hamlin Park, Interurban Trail, Twin Ponds Park, Seattle	B1	1	Hamlin Park: 2.4	4	N/A	N/A
54S	East side of Meridian Avenue N, 60' south of N 175th Street.	S	N: King County Court, Cromwell Park, Shoreline Stadium and Pool, Spartan Rec Ctr	B1	1	Spartan Rec Ctr: 0.9 Shoreline Stadium: 1 Shoreline Pool: 1	5	N/A	N/A
55N	West side of 5th Avenue NE, 30' north of N 175th Street.	N	S: Pinehurst/Northgate	B1	1	N/A	1	N/A	N/A
55S	East side of 5th Avenue NE, 30' south of N 175th Street.	S	N: Shoreline Park, Shoreline Stadium and Pool, Spartan Rec Ctr	B1	1	Spartan Rec Ctr: 0.9 Shoreline Stadium: 0.8 Shoreline Pool: 1.1	4	N/A	N/A
56N	West side of 10th Avenue NE, 30' north of N 175th Street.	N	S: Hamlin Park, Interurban Trail, Paramount School Park	B1	1	Hamlin Park: 1.7	3	N/A	N/A
56S	East side of 10th Avenue NE, 30' south of N 175th Street.	S	N: Shoreline Stadium and Pool, Spartan Rec Ctr	B1	1	Spartan Rec Ctr: 1 Shoreline Stadium: 0.9 Shoreline Pool: 1.3	3	N/A	N/A
57N	West side of 15th Avenue NE, 30' north of N 175th Street.	N	S: Hamlin Park, South Woods, Shorecrest HS	B1	1	Hamlin Park: 0.9 Shorecrest HS: 1.6	3	N/A	N/A
57E	North side of NE 175th Street, 30' east of 15th Avenue NE.	E	N: Burke Gilman Trail, Interurban Trail, Shoreline Stadium and Pool, Spartan Rec Ctr S: Hamlin Park	B1	1	Spartan Rec Ctr: 1.3 Shoreline Stadium: 1.2 Shoreline Pool: 1.5 Hamlin Park: 0.9	6	N/A	N/A
57S	East side of 15th Avenue NE, 30' south of N 175th Street.	S	N: Burke Gilman Trail, Interurban Trail, Shoreline Stadium and Pool, Spartan Rec Ctr	B1	1	Spartan Rec Ctr: 1.3 Shoreline Stadium: 1.2 Shoreline Pool: 1.5	5	N/A	N/A
58E	North side of NE 175th Street, 30' east of 22nd Avenue NE.	E	W: North City, Post Office	B1	1	N/A	2	Post Office	N/A
58W	South side of NE 175th Street, 30' west of 22nd Avenue NE.	W	E: Hamlin Park, South Woods, Shorecrest HS, Burke Gilman Trail	B1	1	Shorecrest HS: 1.1 Hamlin Park: 1.2	4	N/A	N/A
59N	West side of 10th Avenue NE, 30' north of NE 180th Street.	N	N: Interurban Trail S: Paramount School Park E: Hamlin Park, North City	B1	1	Hamlin Park: 1.4	4	N/A	N/A

Table 5: City Wayfinding Signing Matrix

Sign Number	Location (Relative to Intersection)	Sign Facing	Destinations/Content	Sign Type	2- or 1-Sided	Distance (in miles)	Blade Count	Symbol	Comments
59E	North side of NE 180th Street, 30' east of 10th Avenue NE.	E	N: Shoreline Stadium and Pool, Spartan Rec Ctr S: Paramount School Park	B1	1	Spartan Rec Ctr: 0.8 Shoreline Stadium: 0.7 Shoreline Pool: 1	4	N/A	N/A
59S	East side of 10th Avenue NE, 30' south of NE 180th Street.	S	N: Shoreline Stadium and Pool, Spartan Rec Ctr, Interurban Trail E: North City	B1	1	Spartan Rec Ctr: 0.8 Shoreline Stadium: 0.7 Shoreline Pool: 1	5	N/A	N/A
60N	West side of 15th Avenue NE, 30' north of NE 180th Street.	N	S: North City, Hamlin Park W: Interurban Trail, Shoreline Stadium and Pool, Spartan Rec Ctr	B1	1	Spartan Rec Ctr: 1 Shoreline Stadium: 0.9 Shoreline Pool: 1.3 Hamlin Park: 1.1	6	N/A	N/A
60S	East side of 15th Avenue NE, 30' south of NE 180th Street.	S	N: Burke Gilman Trail W: Interurban Trail, Shoreline Stadium and Pool, Spartan Rec Ctr	B1	1	Spartan Rec Ctr: 1 Shoreline Stadium: 0.9 Shoreline Pool: 1.3	5	N/A	N/A
60W	South side of NE 180th Street, 30' west of 15th Avenue NE.	W	N: Burke Gilman Trail S: North City, Hamlin Park	B1	1	Hamlin Park: 1.2	3	N/A	N/A
61N	West side of 15th Avenue NW, 30' north of NW 188th Street.	N	E: Shoreview Park, Interurban Trail, Town Ctr, Hillwood Park, Seattle	B1	1	Shoreview Park: 1.8 Town Ctr: 3.2	5	N/A	N/A
61E	North side of NW 188th Street, 30' east of 15th Avenue NW.	E	N: Richmond Beach, Kayu Kayu Ac Park, Edmonds	B1	1	Richmond Beach: 0.6	3	N/A	N/A
62E	North side of Ridgefield Road NW, 30' east of Springdale Court NW.	E	S: Boeing Creek Park, Shoreview Park, Seattle W: Richmond Beach, Kayu Kayu Ac Park, Edmonds	B1	1	Richmond Beach: 0.8 Shoreview Park: 1.6	6	N/A	N/A
62S	East side of Springdale Court NW, 30' south of Ridgefield Road NW.	S	E: Interurban Trail, Hillwood Park, Town Ctr W: Richmond Beach, Kayu Kayu Ac Park, Edmonds	B1	1	Town Ctr: 3 Richmond Beach: 0.8	6	N/A	N/A
62W	South side of NW 188th Street, 30' west of Springdale Court NW.	W	E: Town Ctr, Interurban Trail, Hillwood Park S: Boeing Creek Park, Shoreview Park, Seattle	B1	1	Shoreview Park: 1.6 Town Ctr: 3	6	N/A	N/A
63E	North side of Innis Arden Drive NW, 30' north of Ridgefield Road NW.	NE	W: Richmond Beach, Shoreview Park, Boeing Creek Park, Kayu Kayu Ac Park	B1	1	Richmond Beach: 1 Shoreview Park: 1.9	4	N/A	N/A
63W	South side of Ridgefield Road NW, 30' west of Innis Arden Drive NW.	NW	E: Hillwood Park, Town Ctr, Interurban Trail, Edmonds	B1	1	Town Ctr: 2.7	4	N/A	N/A
64N	West side of 8th Avenue NW, 30' north of NW Richmond Beach Road.	N	S: Richmond Beach, Shoreview Park, Boeing Creek Park, Kayu Kayu Ac Park	B1	1	Richmond Beach: 1.1 Shoreview Park: 2	4	N/A	Directional arrows on sign blades should point southwest to compensate for soft right turn.
64S	South of Innis Arden Drive NW, west of 8th Avenue NW. Locate at southwest corner of planted median at above intersection.	S	N: Hillwood Park, Town Ctr, Interurban Trail, Edmonds	B1	1	Town Ctr: 2.6	4	N/A	N/A

Table 5: City Wayfinding Signing Matrix



Sign Number	Location (Relative to Intersection)	Sign Facing	Destinations/Content	Sign Type	2- or 1-Sided	Distance (in miles)	Blade Count	Symbol	Comments
65N	West side of Meridian Avenue N, 60' north of N 185th Street.	N	E: Burke Gilman Trail S: District Court W: Town Ctr, Interurban Trail, Police Station, Historical Museum	B1	1	Interurban Trail: 0.4 Town Ctr: 1.1	6	Police	N/A
65E	North side of N 185th Street, 30' east of Meridian Avenue N.	E	N: Edmonds S: District Court W: Town Ctr, Interurban Trail, Historical Museum, Police Station	B1	1	Interurban Trail: 0.4 Town Ctr: 1.1	6	Police	N/A
65S	East side of Meridian Avenue N, 60' south of N 185th Street.	S	E: Shoreline Stadium and Pool, Spartan Rec Ctr, Burke Gilman Trail W: Town Ctr, Interurban Trail	B1	1	Interurban Trail: 0.4 Shoreline Stadium: 0.5 Shoreline Pool: 0.5 Spartan Rec Ctr: 0.4 Town Ctr: 1.1	6	N/A	N/A
65W	South side of N 185th Street, 30' west of Meridian Avenue N.	W	N: Edmonds E: Shoreline Stadium and Pool, Spartan Rec Ctr, Burke Gilman Trail S: District Court	B1	1	Shoreline Stadium: 0.5 Shoreline Pool: 0.5 Spartan Rec Ctr: 0.4	6	N/A	N/A
66E	North side of NE 185th Street, 30' east of 1st Avenue NE.	E	W: Town Ctr, Interurban Trail, Historical Museum, Police Station	B1	1	Town Ctr: 1.3	4	Police	N/A
66W	South side of NE 185th Street, 30' west of 1st Avenue NE.	W	N: Shoreline Pool E: Burke Gilman Trail, North City	B1	1	Shoreline Pool: 0.3	3	N/A	N/A
67E	North side of NE 185th Street, 30' east of 5th Avenue NE.	E	W: Interurban Trail, Town Ctr, Shoreline Pool	B1	1	Town Ctr: 1.5 Shoreline Pool: 0.5	3	N/A	5th Avenue NE located west of I-5.
67W	South side of NE 185th Street, 30' west of 5th Avenue NE.	W	E: Burke Gilman Trail, North City, Hamlin Park	B1	1	Hamlin Park: 1.9	3	N/A	5th Avenue NE located west of I-5.
68E	North side of NE 185th Street, 30' east of 5th Avenue NE.	E	W: Interurban Trail, Town Ctr, Shoreline Stadium and Pool, Spartan Rec Ctr S: Library	B1	1	Shoreline Stadium: 0.2 Shoreline Pool: 0.6 Spartan Rec Ctr: 0.4 Town Ctr: 1.6	6	Library	5th Avenue NE located east of I-5.
68S	East side of 5th Avenue NE, 30' south of NE 185th Street.	S	E: Burke Gilman Trail, Hamlin Park W: Shoreline Stadium and Pool, Spartan Rec Ctr, Town Ctr	B1	1	Hamlin Park: 1.8 Town Ctr: 1.6 Shoreline Stadium: 0.2 Shoreline Pool: 0.6 Spartan Rec Ctr: 0.4	6	N/A	5th Avenue NE located east of I-5.
68W	South side of NE 185th Street, 30' west of 5th Avenue NE.	W	E: Burke Gilman Trail, North City, Hamlin Park S: Library	B1	1	Hamlin Park: 1.8	4	Library	5th Avenue NE located east of I-5.
69N	West side of 10th Avenue NE, 30' north of NE 185th Street.	N	S: Hamlin Park, North City W: Shoreline Stadium and Pool, Spartan Rec Ctr, Town Ctr	B1	1	Hamlin Park: 1.7 Town Ctr: 1.8 Shoreline Stadium: 0.4 Shoreline Pool: 0.8 Spartan Rec Ctr: 0.5	6	N/A	N/A

Table 5: City Wayfinding Signing Matrix

Sign Number	Location (Relative to Intersection)	Sign Facing	Destinations/Content	Sign Type	2- or 1-Sided	Distance (in miles)	Blade Count	Symbol	Comments
69S	East side of 10th Avenue NE, 30' south of NE 185th Street.	S	N: Burke Gilman Trail W: Interurban Trail, Shoreline Stadium and Pool, Spartan Rec Ctr	B1	1	Spartan Rec Ctr: 0.5 Shoreline Stadium: 0.4 Shoreline Pool: 0.8	5	N/A	N/A
69W	South side of NE 185th Street, 30' west of 10th Avenue NE.	W	N: Burke Gilman Trail S: Hamlin Park, North City	B1	1	Hamlin Park: 1.7	3	N/A	N/A
70N	West side of 10th Avenue NE, 30' north of NE Perkins Way.	N	E: Burke Gilman Trail S: North City	B1, E, D2	1	N/A	2	N/A	D2 arrow points east.
70E	North side of NE Perkins Way, 30' north of 10th Avenue NE.	E	N: Interurban Trail S: Shoreline Stadium and Pool, Spartan Rec Ctr, Town Ctr	B1, E, D2	1	Town Ctr: 2.1 Shoreline Stadium: 0.7 Shoreline Pool: 1 Spartan Rec Ctr: 0.8	5	N/A	D2 arrow points north.
70S	East side of 10th Avenue NE, 30' south of NE 190th Street.	S	N: Interurban Trail, Echo Lake Park E: Burke Gilman Trail	B1, E, D3	1	N/A	3	N/A	N/A
71N	West side of 15th Avenue NE, 30' north of NE Perkins Way.	N	E: Lake Forest Park, Burke Gilman Trail S: North City W: Town Ctr, Interurban Trail, Spartan Rec Ctr	B1, E, D3	1	Spartan Rec Ctr: 1.1 Town Ctr: 2.4	6	N/A	N/A
71E	North side of NE Perkins Way, 30' east of 15th Avenue NE.	E	W: Shoreline Stadium and Pool, Spartan Rec Ctr, Town Ctr, Interurban Trail	B1, E, D3	1	Town Ctr: 2.4 Shoreline Stadium: 1 Shoreline Pool: 1.4 Spartan Rec Ctr: 1.1	5	N/A	Sign E and D3 mounted parallel to roadway.
71S	East side of 15th Avenue NE, 30' south of NE Perkins Way.	S	E: Lake Forest Park, Burke Gilman Trail W: Town Ctr, Interurban Trail, Spartan Rec Ctr	B1, E, D3	1	Spartan Rec Ctr: 1.1 Town Ctr: 2.4	5	N/A	N/A
71W	South side of NE Perkins Way, 30' west of 15th Avenue NE.	W	E: Lake Forest Park, Burke Gilman Trail	B1, E, D3	1	N/A	2	N/A	Sign E and D3 mounted parallel to roadway.
72E	North side of NE Perkins Way, locate on City boundary line.	E	W: Shoreline Stadium and Pool, Spartan Rec Ctr, Town Ctr, Interurban Trail	B1, B2, E, D3	1	Town Ctr: 2.8 Shoreline Stadium: 1.4 Shoreline Pool: 1.7 Spartan Rec Ctr: 1.5	5	N/A	Sign E and D3 mounted parallel to roadway.
72W	South side of NE Perkins Way, 30' east of 20th PINE.	W	E: Burke Gilman Trail	C, E, D3	1	N/A	1	N/A	Sign Type C - To Lake Forest Park. Sign E and D3 mounted parallel to roadway.
73N	West side of Richmond Beach Drive NW, 30' north of NW 196th Street.	N	E: Shoreview Park, Town Ctr, Interurban Trail, RB Community Park, RB Saltwater Park	B1	1	Shoreview Park: 2.8 Town Ctr: 4.2	5	N/A	N/A
73E	North side of NW 196th Street, 30' east of Richmond Beach Drive NW.	E	N: Kayu Kayu Ac Park	B1	1	N/A	1	N/A	N/A

Table 5: City Wayfinding Signing Matrix



Sign Number	Location (Relative to Intersection)	Sign Facing	Destinations/Content	Sign Type	2- or 1-Sided	Distance (in miles)	Blade Count	Symbol	Comments
74E	North side of NW 195th Street, 30' east of 20th Avenue NW.	E	N: Edmonds S: RB Saltwater Park W: RB Community Park, Kayu Kayu Ac Park, RB Library	B1	1	N/A	5	Library	N/A
74W	South side of NW 196th Street, 30' west of 20th Avenue NW.	W	N: Edmonds E: Shoreview Park, Town Ctr S: RB Saltwater Park	B1	1	Shoreview Park: 2.4 Town Ctr: 3.7	4	N/A	N/A
75S	East side of 15th Avenue NW, 30' south of NW Richmond Beach Road.	S	N: Kruckenberg Botanic Garden W: Richmond Beach, Kayu Kayu Ac Park, Edmonds	B1	1	Richmond Beach: 0.3	4	N/A	N/A
75W	South side of NW 195th Street, 50' west of 15th Avenue NW.	W	S: Shoreview Park, Town Ctr, Interurban Trail, Hillwood Park, Seattle	B1	1	Shoreview Park: 2.1 Town Ctr: 3.5	5	N/A	N/A
76E	North side of NW 195th Street, 30' east of 8th Avenue NW.	E	N: Edmonds S: Richmond Beach, Shoreview Park	B1	1	Richmond Beach: 1.5 Shoreview Park: 2.4	3	N/A	N/A
76S	East side of 8th Avenue NW, 30' south of NW 195th Street.	S	N: Edmonds E: Town Ctr, Interurban Trail, Shoreline Park-n-Ride, Hillwood Park	B1	1	Town Ctr: 2.2	5	Transit	N/A
77E	North side of NW 195th Street, 30' east of 3rd Avenue NW.	E	S: Hillwood Park W: Richmond Beach, Edmonds	B1	1	Richmond Beach: 1.8	3	N/A	N/A
77W	South side of NW 195th Street, 30' west of 3rd Avenue NW.	W	E: Town Ctr, Interurban Trail, Shoreline Park-n-Ride S: Hillwood Park	B1	1	Town Ctr: 2	4	Transit	N/A
78S	East side of Fremont Avenue N, 30' south of N 195th Street.	S	W: Hillwood Park, Richmond Beach, Kayu Kayu Ac Park	B1	1	Richmond Beach: 2.3	3	N/A	N/A
78W	South side of N 195th Street, 30' west of Fremont Avenue N.	W	S: Town Ctr, Interurban Trail, Shoreline Park-n-Ride, Richmond Highlands Rec	B1	1	Interurban Trail: 0.5 Town Ctr: 1.5	4	Transit	N/A
79N	West side of Fremont Avenue N, 30' north of N 193rd Street.	N	E: Town Ctr, Interurban Trail, Shoreline Park-n-Ride S: Richmond Highlands Rec, Shorewood HS	B1	1	Interurban Trail: 0.4 Shorewood HS: 0.9 Town Ctr: 1.4	5	Transit	N/A
79E	North side of N 193rd Street, 30' east of Fremont Avenue N.	E	N: Hillwood Park, Richmond Beach, Kayu Kayu Ac Park S: Shorewood HS	B1	1	Shorewood HS: 0.9 Richmond Beach: 2.4	4	N/A	N/A
80S	East side of Firlands Way N, 30' south of N 193rd Street.	S	W: Hillwood Park, Richmond Beach, Kayu Kayu Ac Park, Richmond Highlands Rec	B1	1	Richmond Beach: 2.5	4	N/A	N/A
80W	South side of N 193rd Street, 30' west of Firlands Way N.	W	S: Interurban Trail, Town Ctr, Shoreline Park-n-Ride, Echo Lake Park	B1	1	Interurban Trail: 0.3 Town Ctr: 1.3	4	Transit	N/A

Table 5: City Wayfinding Signing Matrix

Sign Number	Location (Relative to Intersection)	Sign Facing	Destinations/Content	Sign Type	2- or 1-Sided	Distance (in miles)	Blade Count	Symbol	Comments
81N	West side of Firlands Way N, 30' north of N 192nd Street.	N	E: Interurban Trail, Town Ctr, Shoreline Park-n-Ride, Echo Lake Park	B1	1	Interurban Trail: 0.3 Town Ctr: 1.2	4	Transit	N/A
81E	North side of N 192nd Street, 30' east of Firlands Way N.	E	N: Hillood Park, Richmond Beach, Kayu Kayu Ac Park, Richmond Highlands Rec	B1	1	Richmond Beach: 2.5	4	N/A	N/A
82N	West side of Meridian Avenue N, 30' north of N 195th Street.	N	E: Shoreline Pool, Spartan Rec Ctr, Burke Gilman Trail S: District Court W: Interurban Trail, Echo Lake Park	B1, E, D3	1	Interurban Trail: 0.3 Shoreline Pool: 0.5 Spartan Rec Ctr: 0.8	6	N/A	N/A
82E	North side of N 195th Street (trail), 30' east of Meridian Avenue N.	E	N: Edmonds S: District Court W: Interurban Trail, Town Ctr, Echo Lake Park	B1, E, D3	1	Interurban Trail: 0.3 Town Ctr: 1.5	5	N/A	Sign E and D3 mounted parallel to roadway.
82S	East side of Meridian Avenue N, 30' south of N 195th Street (trail).	S	N: Edmonds E: Shoreline Pool, Spartan Rec Ctr, Burke Gilman Trail W: Interurban Trail, Echo Lake Park	B1, E, D3	1	Interurban Trail: 0.3 Shoreline Pool: 0.5 Spartan Rec Ctr: 0.8	6	N/A	N/A
82W	South side of N 195th Street, 30' west of Meridian Avenue N.	W	N: Edmonds E: Shoreline Stadium and Pool, Spartan Rec Ctr, Burke Gilman Trail S: District Court	B1, E, D3	1	Spartan Rec Ctr: 0.8 Shoreline Stadium: 0.9 Shoreline Pool: 0.5	6	N/A	Sign E and D3 mounted parallel to roadway.
83E	North side of NE 195th Street, 30' east of 1st Avenue NE.	E	S: Shoreline Pool, Spartan Rec Ctr, Shoreline Park W: Town Ctr, Echo Lake Park, Interurban Trail	B1, E, D3	1	Spartan Rec Ctr: 0.6 Shoreline Pool: 0.2 Town Ctr: 1.7	6	N/A	Sign E and D3 mounted parallel to roadway.
83S	East side of 1st Avenue NE, 30' south of NE 195th Street.	S	E: Burke Gilman Trail W: Town Ctr, Echo Lake Park, Interurban Trail	B1, E, D3	1	Town Ctr: 1.7	4	N/A	N/A
83W	South side of N 195th Street (trail), 30' west of 1st Avenue NE.	W	E: Burke Gilman Trail S: Shoreline Stadium and Pool, Spartan Rec Ctr, Shoreline Park	B1, E, D3	1	Spartan Rec Ctr: 0.6 Shoreline Stadium: 0.7 Shoreline Pool: 0.2	5	N/A	Sign E and D3 mounted parallel to roadway.
84E	North side of NE 195th Street, 30' east of 5th Avenue NE.	E	W: Shoreline Stadium and Pool, Spartan Rec Ctr, Town Ctr, Echo Lake Park, Interurban Trail	B1, E, D3	1	Spartan Rec Ctr: 0.8 Shoreline Stadium: 0.9 Shoreline Pool: 0.5 Town Ctr: 2	6	N/A	Sign E and D3 mounted parallel to roadway.
84S	East side of 5th Avenue NE, 30' south of NE 195th Street.	S	E: Burke Gilman Trail W: Shoreline Pool, Shoreline Park, Town Ctr, Echo Lake Park, Interurban Trail	B1, E, D3	1	Shoreline Pool: 0.5 Town Ctr: 2	6	N/A	N/A
84W	South side of NE 195th Street, 30' west of 5th Avenue NE.	W	E: Burke Gilman Trail	B1, E, D2	1	N/A	1	N/A	Sign E and D3 mounted parallel to roadway.

Table 5: City Wayfinding Signing Matrix



Sign Number	Location (Relative to Intersection)	Sign Facing	Destinations/Content	Sign Type	2- or 1-Sided	Distance (in miles)	Blade Count	Symbol	Comments
85S	East side of 10th Avenue NE, 30' south of NE 195th Street.	S	W: Town Ctr, Shoreline Stadium and Pool, Spartan Rec Ctr, Echo Lake Park, Interurban Trail	B1, E, D2	1	Spartan Rec Ctr: 1.1 Shoreline Stadium: 1.2 Shoreline Pool: 0.7 Town Ctr: 2.2	6	N/A	D2 arrow points west.
85W	South side of NE 195th Street, 30' west of 10th Avenue NE.	W	S: Burke Gilman Trail	B1, E, D2	1	N/A	1	N/A	D2 arrow points south.
86	West side of 15th Avenue NE, 30' south of NE 196th Street.	N	S: Burke Gilman Trail, Post Office, North City, Hamlin Park, Town Ctr	B1	1	Hamlin Park: 2 Town Ctr: 2.7	5	Post Office	N/A
87	West side of 25th Avenue NE, 100' north of Ballinger Way NE.	N	S: To Lake Forest Park	C	1	N/A	N/A	N/A	N/A
88	West side of 19th Avenue NE, 30' north of Ballinger Way NE.	N	S: Burke Gilman Trail, Post Office, North City, Hamlin Park	B1	1	Hamlin Park: 2.4	4	Post Office	N/A
89N	West side of 20th Avenue NW, 30' north of NW 205th Street.	N	S: RB Saltwater Park, RB Community Park, Shoreview Park	B1, B2, C	1	Shoreview Park: 2.9	3	N/A	Not in City limits.
89S	East side of 20th Avenue NW, 30' south of NW 205th Street.	S	N: To Edmonds	C	1	N/A	N/A	N/A	N/A
90N	West side of 8th Avenue NW, 30' north of NW 205th Street.	N	S: Hillwood Park, Town Ctr, Richmond Beach, Shoreview Park	B1, B2, C	1	Richmond Beach: 2 Shoreview Park: 2.9	4	N/A	Not in City limits.
90S	East side of 8th Avenue NW, 30' south of NW 205th Street.	S	N: To Edmonds	C	1	N/A	N/A	N/A	N/A
91	West side of 15th Avenue NE, south of NE 205th Street at pedestrian crossing.	N	S: To Shoreline	B1, B2	1	N/A	1	N/A	N/A
92	West side of 56th Avenue W, 30' north of NE 205th Street.	N	S: To Shoreline	B1, B2	1	N/A	1	N/A	Not in City limits.
93	West side of 52nd Avenue W, 30' north of NE 205th Street.	N	S: To Shoreline	B1, B2	1	N/A	1	N/A	Not in City limits.

Table 5: City Wayfinding Signing Matrix

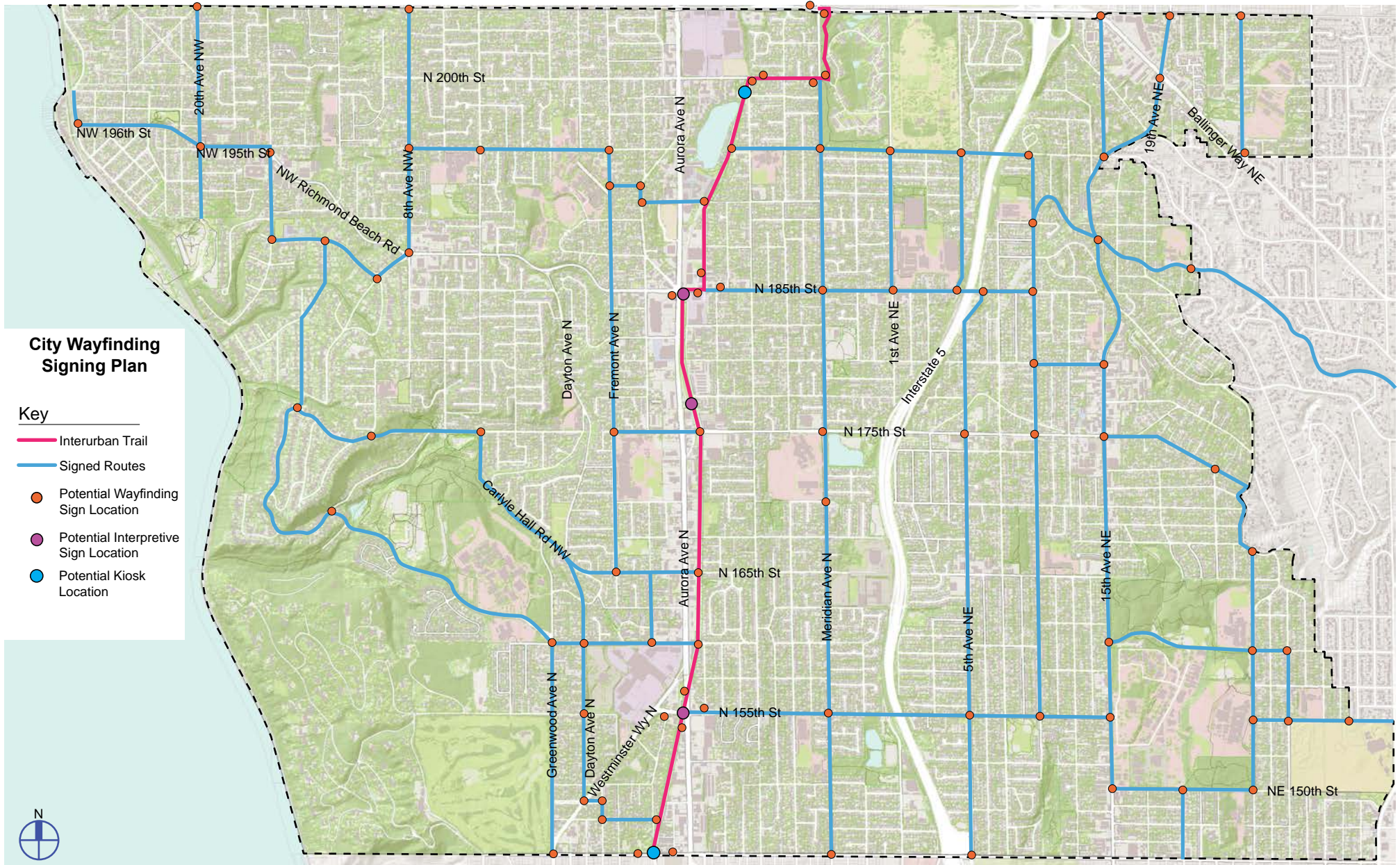

Figure 2: City Wayfinding Signing Plan

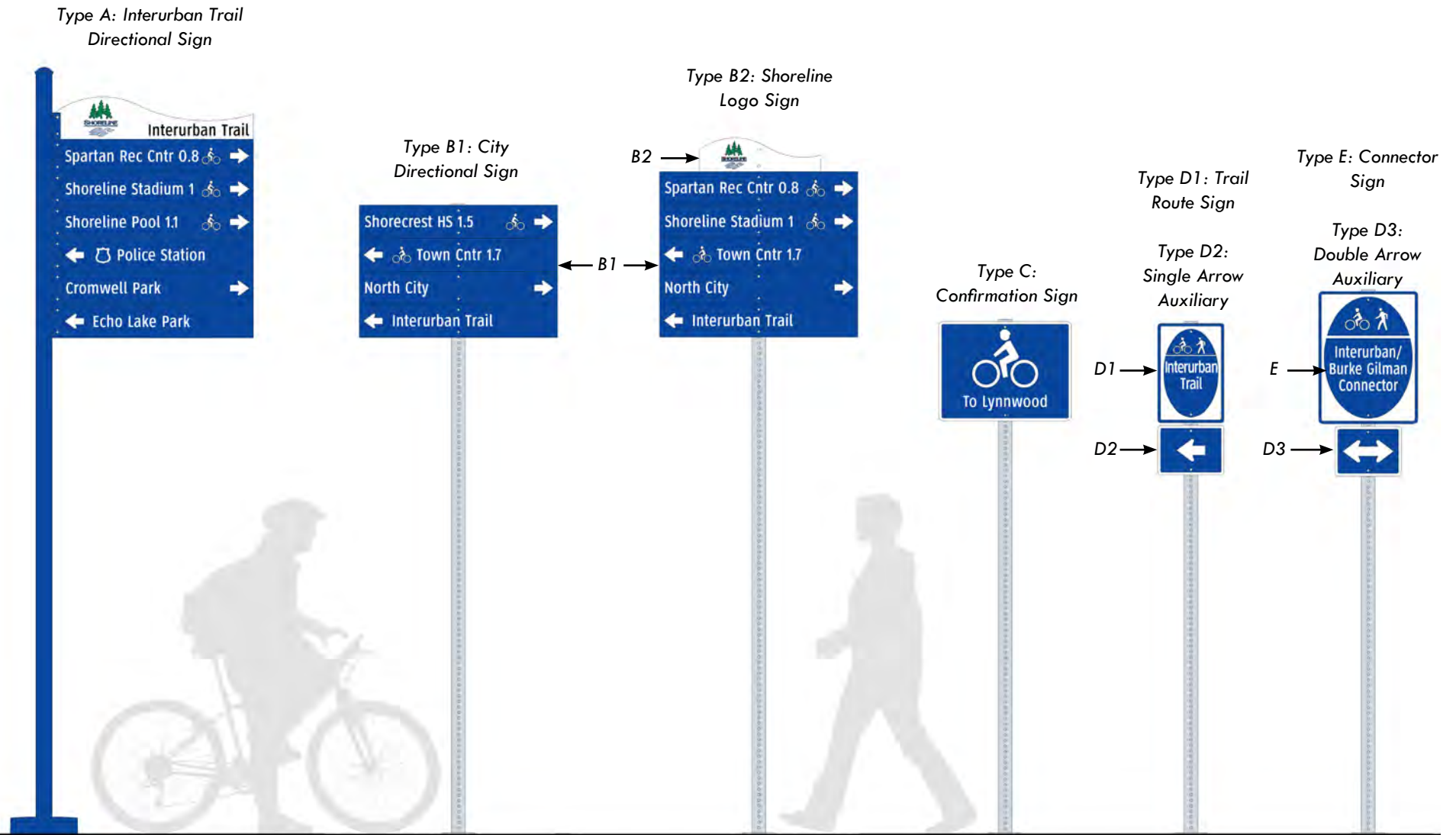

Figure 5: City Wayfinding Sign Family