



CITY OF
SHORELINE



2007

P r o p o s e d B u d g e t
S h o r e l i n e , W A

J a n u a r y 1, 2007—D e c e m b e r 31, 2007



2007 Proposed Budget

Robert L. Ransom, Mayor
Maggie Fimia, Deputy Mayor
Rich Gustafson, Councilmember
Ron Hansen, Councilmember
Keith McGlashan, Councilmember
Cindy Ryu, Councilmember
Janet Way, Councilmember

Robert Olander, City Manager
Debbie Tarry, Finance Director

Prepared by the Finance Department
For Fiscal Year January 1, 2007 - December 31, 2007

For more detail, copies of the 2007 Budgets are available on the City's web site, at City Hall, both Neighborhood Police Centers, Shoreline Library and Richmond Beach Library



GOVERNMENT FINANCE OFFICERS ASSOCIATION

*Distinguished
Budget Presentation
Award*

PRESENTED TO

**City of Shoreline
Washington**

For the Fiscal Year Beginning

January 1, 2006

President

Executive Director

The Government Finance Officers Association (GFOA) of the United States and Canada presented a Distinguished Budget Presentation Award to the City of Shoreline for its annual budget for the 2006 fiscal year beginning January 1, 2006. In order to receive this award, a governmental unit must publish a budget document that meets program criteria as a policy document, as an operations guide, as a financial plan, and as a communication device.

The award is valid for a period of one year only. We believe our current budget continues to conform to program requirements, and we are submitting it to GFOA to determine its eligibility for another award.



2007 Proposed Budget

Table of Contents

Page

Introduction

Reader's Guide to the Budget.....	1
City Organization Chart.....	3
Shoreline Community Profile	4
Budget Procedures and Process.....	15
Budget Calendar.....	20
General Budget Policies.....	21
City Vision, Values & Council Workplan	23

City Manager's Transmittal Letter

City Manager's 2006 Budget Message.....	27
Shoreline Strategic Directions 2007-2008.....	47A

Executive Summary

City Resources and Expenditures by Category.....	48
City Budget Summary.....	49
All Funds Resources/Expense Summary.....	50
Operating Budget Six Year Forecast	51
2006 Revenue Sources.....	52
Expenditures by Object Category.....	76
2006 Budget Distributed by Critical Success Factor	77
2006 Program Budget Summary.....	78
Ending Fund Balances.....	79
Change in Ending Fund Balances.....	80
Municipal Debt Capacity.....	81
Other Long-Term Debt.....	82
Schedule of Long-Term Debt	83
Debt Policies	84

Operating Budget

Department/Fund Overview.....	86
2006 FTE Summary and Explanation of Changes.....	87
2006 Budgeted Positions.....	88
City Council.....	92
City Manager.....	98
City Clerk.....	108
Communications and Intergovernmental Relations.....	116
Human Services.....	124
City Attorney.....	130
Finance	136
Human Resources.....	154
Customer Response Team.....	160
Police.....	170
Criminal Justice.....	190
Parks, Recreation and Cultural Services.....	196
Planning and Development Services.....	216
Economic Development	234
Public Works.....	240

Budget By Fund

City Fund Structure.....	262
All Funds Historical Revenue/Expenditures Summary.....	264
General Fund Summary.....	265
Street Fund Summary.....	266
Arterial Street Fund Summary.....	267
Surface Water Management Fund Summary.....	268
General Reserve Fund Summary.....	269



2007 Proposed Budget

Table of Contents

Page

Introduction

Development Services Fund Summary.....	270
Code Abatement Fund Summary.....	271
Asset Seizure Fund Summary.....	272
Public Arts Fund Summary.....	273
General Capital Fund Summary.....	274
City Facility Major Maintenance Fund.....	275
Roads Capital Fund Summary.....	276
Surface Water Capital Fund Summary.....	277
Vehicle Operations and Maintenance Fund Summary.....	279
Equipment Replacement Fund Summary.....	280
Unemployment Fund Summary.....	281
Revenue and Expenditure Report for All Funds.....	283

Capital Improvement Program

Introduction.....	286
Impacts of Growth Management.....	286
Capital Improvement Fund Descriptions	287
Capital Budget Criteria.....	288
Advantages of Capital Planning	288
Capital Improvement Plan Policies.....	289
2007-2012 Capital Resources by Category.....	295
2007-2012 Capital Projects by Category.....	296
2007-2012 Capital Program Summary.....	297
2007-2012 General Capital Fund.....	302
2007-2012 Facilities Major Maintenance Fund	304
2007-2012 Roads Capital Fund.....	306
2007-2012 Surface Water Capital Fund.....	308

Appendix

Financial Policies.....	310
2007 Salary Schedule.....	320
2007 Fee Schedule.....	328
Department Revenue Detail.....	339
Department Expenditure Detail	348
Expenditure Categories	369
Glossary of Budget Terms and Acronyms.....	372



INTRODUCTION

READER'S GUIDE TO THE BUDGET

The City's budget, in its basic structure, is similar to a family household budget. What a family spends (city expenditures), must not exceed its income (city revenues), and to be prudent a family should also place some of its income each year in a savings account (city reserves) to cover future emergencies or unanticipated opportunities.

Once beyond the basic comparisons, however, budgets for cities are certainly more complex than a family or even a small business would require. Cities draw their revenues from a wide variety of sources, divide their expenditures into separate funds and allocate their program expenditures in ways that serve the special needs of municipal services. Much of this complexity is created to allow for proper accounting and tracking techniques that are established by State law. Unlike the federal government, the City of Shoreline must adopt a balanced budget.

Organization of this Document

This budget document is organized into seven sections to facilitate the reader's understanding of the City's 2007 budget and to help the reader to find information regarding the City and its budget. Those seven sections are: Introduction, Transmittal Letter, Executive Summary, Operating Budget, Budget by Fund, Capital Improvement Program, and Appendix.

Introduction – This section is designed to introduce the reader to the City and the budget process. It includes the following:

- ◆ Table of Contents
- ◆ Reader's Guide
- ◆ City Organization Chart
- ◆ Shoreline Community Profile
- ◆ Budget Procedures and Process
- ◆ Budget Calendar
- ◆ Budget Ordinance
- ◆ General Budget Policies
- ◆ City Vision, Values & Work Plan

Transmittal Letter - This section includes the City Manager's 2007 budget message to the City Council and the City's Performance, Results, and Outcomes (PRO) Card.

Executive Summary – This section provides an overview of the City's financial condition and includes:

- ◆ City Resources and Expenditures by Category
- ◆ City Budget Summary
- ◆ All Funds Resources/Expense Summary
- ◆ Operating Budget Forecast
- ◆ 2007 Revenue Sources
- ◆ Expenditures by Object Category
- ◆ 2007 Program Budget Summary
- ◆ Ending Fund Balances
- ◆ Change in Ending Fund Balances
- ◆ Municipal Debt Capacity, City Long Term Debt, and City Debt Policy

Operating Budget – This section highlights the departmental budgets. It is organized to give the reader various levels of information by including department and program overviews. It includes:

- ◆ Department/Fund Overview
- ◆ 2007 FTE Summary
- ◆ 2007 Budgeted Positions

Department Budgets

- ◆ Mission Statement
- ◆ Programs
- ◆ Historical Comparison of Total Expenditures, % of General Fund, and FTE's
- ◆ 2006 Key Accomplishments
- ◆ 2007 Key Department Objectives
- ◆ Historical Comparison of Expenditure/Revenue Categories
- ◆ Historical Program Comparison
- ◆ Historical Fund Comparison
- ◆ 2007 Budget Changes
- ◆ Program Detail

Budget by Fund – This section illustrates the financial condition of each of the City's funds. It includes:

- ◆ City Fund Structure
- ◆ All Funds Historical Revenue/Expenditure Summary
- ◆ Fund Summaries
- ◆ Revenue and Expenditure Report for All Funds

Capital Improvement Program – This section identifies the multi-year plan for the three Capital Funds; General Capital (improvements to Parks and Facilities), Roads Capital (street, sidewalk, and traffic improvements), and Surface Water Capital (drainage improvements). A summary of each fund's projects is included. This section includes:

- ◆ Impacts of Growth Management
- ◆ Capital Budget Criteria
- ◆ Advantages of Capital Planning
- ◆ Description of Capital Funds
- ◆ Capital Improvement Plan Policies
- ◆ Impact of CIP on Operating Budgets
- ◆ 2007– 2012 CIP Expenditures and Resources by Category
- ◆ 2007 Capital Program Summary
- ◆ 2007– 2012 CIP Expenditures and Resources by Fund

Appendix – This section includes:

- ◆ Financial Policies
- ◆ 2007 Salary Table
- ◆ 2007 Fee Schedules
- ◆ Expenditure and Revenue Detail
- ◆ Expenditure Categories
- ◆ Glossary of Budget Terms

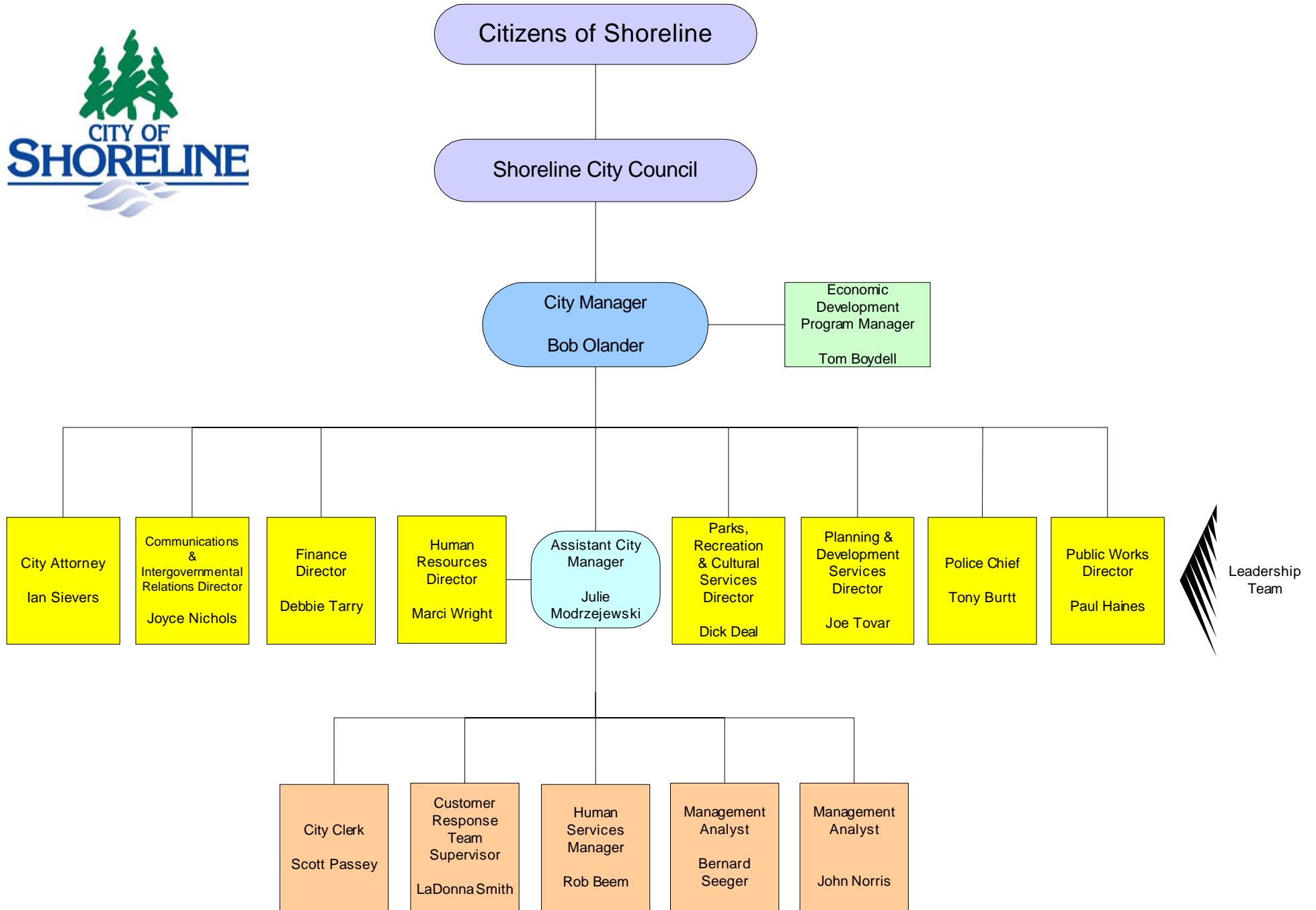

SHORELINE COMMUNITY PROFILE



Demographics (from 2000 Census Data)	
Male/Female.....	48.2%/51.8%
Median Age	39.3
% under 20	24.9
Households.....	20,716
Owner Occupied Housing Units.....	68%
Median Value of Unit.....	\$205,300
Educational Attainment:	
B.A. or higher.....	37.3%
H.S. or Higher.....	90.2%
Median Household Income.....	\$51,658
Per Capita Income.....	\$24,959
Families in Poverty	4.4%

The City of Shoreline was incorporated on August 31, 1995, and operates as a Council/Manager form of government. The Council is comprised of seven members, elected at large by citizens of Shoreline. They are part-time officials who exercise the legislative powers of the City and determine matters of policy.

The Mayor is a council member selected by the Council to chair meetings, authenticate documents and serves as the City’s ceremonial head. The Council is supported by various advisory boards and commissions. The Council appoints a full-time City Manager who serves as the professional administrator of the organization, coordinating day-to-day activities.

SHORELINE AT A GLANCE	
Population.....	52,830
Elevation (average)	375 feet
Highest Elevation	536 feet
Land Area.....	7500 acres (11.7 sq.mi.)
Average Temperature.....	52.8
Average Annual Precipitation.....	38 in.
Miles of City Streets	191*
*(includes 36 mi. arterials, 4 mi. state roads, 3 mi. Interstate & 148 mi. residential streets)	
Residential Dwellings	21,338
City Retail Sales Tax.....	8.8 or 9.3% (Food and Beverage)
City Employees (Full-Time)	145.2
Assessed Valuation.....	\$5,965,510,119



The City of Shoreline is located in the northwestern corner of King County along the shores of Puget Sound. Shoreline is generally bounded by the City of Lake Forest Park to the east, the City of Seattle to the south, Puget Sound to the west, and Snohomish County to the north (including the Cities of Mountlake Terrace and Edmonds, and the Town of Woodway).

Shoreline Yesterday

Before the Turn of the Century: The area which is now Shoreline was once forested with deep woods, pockets of meadows, and bog areas. The area provided rich fishing, hunting, and gathering opportunities for local Native Americans, who occupied permanent settlements along Lake Washington, and temporary camps on Puget Sound. Homesteaders began arriving in the area in the 1880's, following the loggers and mill owners who had earlier set up operations along the waterways. Farmers cleared the fields and built modest homes. Richmond Beach is the site of the first village in the area. Located on the new Great Northern railroad line running along Puget Sound, this area gained its identity in 1890. By the turn of the century, numerous businesses were clustered around Market Street, now known as N.W. 195th Place.

Early 1900's until World War I: By the early 1900's an additional community had developed up the hill known as the Richmond Highlands centered at the current intersection of Aurora and 185th. The Interurban Railroad increased access to the area upon its opening from Seattle to Halls Lake in 1906. The next year the Great Northern railroad depot opened, providing additional transportation facilities to the area. Around 1910, the Seattle Golf Club and the Highlands were established, and Greenwood, or Country Club Road, as it was known then, was the only good road into Seattle. The Interurban was completed to Everett that year, causing more development along its line, particularly in the Ronald area, located roughly along 175th. The North Trunk Road, now known as Aurora or highway 99, was bricked in 1914 and became the primary automobile corridor in the area.

Between World War I and World War II: In the 1920's, 30's and 40's residential development continued. The area that became known as North City developed in the late 1920's along 15th Ave. N.E., and Lago Vista was also developed during this period with its own clubhouse. During this time, the North Trunk Road was upgraded and became known as Aurora, and was designated as Highway 99 in 1930. Aurora served as the emerging center of commerce, and by the mid-20's was home to numerous businesses and roadhouses. Innis Arden was developed by the Boeing Family, and became a prime residential community in the 1940's.

Following World War II: The area which is now Shoreline experienced tremendous growth after World War II as the suburban lifestyle grew in popularity. The Shoreline School District was established in 1944, and in response to the growth, Shoreline High School was built in 1955. Shoreline Community College was founded in 1963 and the I-5 freeway was opened the next year. Commercial development thrived along Aurora in the mid-60's with the opening of Aurora Village and Sears.

Through the 60's, 70's and 80's the community continued to grow. Additional parks and schools were developed including Shorewood and Shorecrest High

Schools, and changes were made to reflect the needs of the community. Shoreline High became the Shoreline Center, and a site that had once been considered for a high school to be called Shoreview High became Shoreview Park. Richmond Beach Park, Hamlin Park, and Ronald Bog Park were significant additions to the Parks system in the area.

In January of 1992, a citizen effort called "Vision Shoreline" organized to promote incorporation of Shoreline as a city. In September of 1994, the incorporation of Shoreline was approved by an overwhelming majority of voters. Following the election, a "Transition Team" was formed to organize the incorporation effort. This effort was successful and Shoreline officially incorporated on August 31, 1995.

Shoreline Today

Over the years, Shoreline has become a community distinguished by strong neighborhoods, excellent schools and parks. According to the Census 2000, Shoreline is home to 53,025. The State Office of Financial Management has estimated the 2004 to be 52,740. The City is now substantially developed with less than 1% of its total area (about 12 square miles) remaining vacant or available for use. Shoreline is primarily residential in character and over 74% of the households are single-family homes. Commercial development stretches along Aurora Avenue with other neighborhood centers located at intersections of primary arterials such as N. 175th Street at 15th Avenue N.E. and N. 185th Street at 8th Avenue N.W. There is limited industrial development. There is a substantial number of institutional, public or tax exempt uses, including cemeteries, schools, public services and churches. Significant lands are devoted to open space, including regional parks, the Boeing creek ravine, and the Seattle Golf Course.

Shorelines

The City of Shoreline has several shorelines totaling 3.4 miles. Puget Sound, the primary shoreline, extends the length of the western edge of the City. It is the City's only shoreline of statewide significance, as defined by the Washington State Shorelines Management Act. The City regulates these shorelines as a part of the Comprehensive Plan process. Designations are intended to reflect the character of land adjacent to the shorelines and guide and regulate development in these areas. The Washington State Department of Ecology reaffirms regulations, as determined by local governments, for shorelines of statewide significance.

In addition, the City has several lakes and ponds including Echo Lake, Ronald Bog and Twin Ponds. Finally, there are several creeks and streams that run through Shoreline and the potential annexation areas. City regulations may also be set for these shorelines. The State does not have to affirm these regulations, but our regulations need to be consistent with State laws.

Neighborhoods

Upon incorporation, the City supported the concept of neighborhood organizations. Twelve neighborhood organizations were recognized or organized by the City, and one was added later through annexation. The following is a short description of each neighborhood.

Ballinger: This area was annexed into the City of Shoreline in two sections A-3 in 1998 and A-2 in 1999. This area is east of I-5, South of NE 205th St (North City Limit), West of 30th Ave NE (East City Limit) and generally north of NE 195th St.

Briarcrest: The area commonly referred to as Briarcrest (or Annexation Area B) was annexed into the City of Shoreline in February of 1997. This area is east of the Ridgecrest neighborhood and extends to the western City limits of Lake Forest Park.

Echo Lake: Echo Lake is the central natural landmark of this neighborhood located on the northern edge of the City and bounded by Aurora Avenue, N.E. 185th Street and I-5.

Highland Terrace: This neighborhood is located just to the east of the Highlands neighborhood and Shoreline Community College. It is also bounded by the Seattle Golf Club, Westminster Way and Aurora Avenue.

Hillwood: The Hillwood community is located along the northern edge of the City between Aurora Avenue and the Richmond Beach neighborhood north of N. 185th Street and N.W. Richmond Beach Road and south of N.W. 205th Street.

Innis Arden: This neighborhood was developed in the 1940s and the neighborhood organization has been in existence since that time. Bordered in part by Shoreview Park, it is located on the western edge of the City along Puget Sound.

Meridian Park: Meridian Park contains portions of the historic Ronald community dating back to the early 1900s. It is located at the core of Shoreline and is bounded by N.E. 185th Street, I-5, N. 160th Street and Aurora Avenue.

North City: Founded around the late 1930s and early 1940s, this neighborhood is located in the northeastern portion of Shoreline and is bounded by I-5, N.E. 175th Street and the eastern edge of the City.

Parkwood: Parkwood is located along the southern edge of the City between Aurora Avenue and I-5. This neighborhood dates back to the early part of the century.

Richmond Beach: This area was settled in the late 1800s and is located in the Northwest corner of the City along Puget Sound.

Richmond Highlands: The Richmond Highlands neighborhood was first settled around the turn of the century. Bordered by N. 185th Street, Aurora Avenue, N. 165th Street and the Innis Arden neighborhood, the area is located in the core of Shoreline.

The Highlands: Designed by the Olmstead Brothers, this neighborhood dates back to 1910. It is located overlooking Puget Sound on the western edge of the City.

Westminster Triangle: This area is located at the southern gateway to the City along Westminster Way and Aurora Avenue.

Ridgecrest: Ridgecrest started developing around the end of World War II and is located in the southeastern corner of the City. It is roughly bordered by I-5, N.E. 15th Street, N.E. 175th Street and N.E. 145th Street.

Commercial Areas

The Aurora Corridor is a major north-south state route (Highway 99) corridor that runs through Shoreline. Highway 99 is one of three north-south state routes in the region and is also the primary non-freeway transportation corridor in the City of Shoreline.

The Aurora Avenue corridor has been primarily a commercial strip for thirty years, containing a wide variety of retail and service uses serving local and regional markets. Office uses are scattered throughout the corridor while residential uses (e.g. apartments, condos, mobile homes and small pockets of single-family homes) are limited to the areas along or near Aurora Avenue.

A number of institutional uses, public uses and government uses are located in or near the Aurora Corridor. These uses include Shoreline Community College, CRISTA Schools, the fire station, the City of Shoreline municipal offices, the Shoreline Sewer District, Shoreline Historical Museum, Washington State Department of Transportation, and METRO facilities (e.g. bus transfer center, park/ride lot).

Other commercial areas include North City, Ridgecrest, and Richmond Beach. The North City business district is located on 15th Avenue N.E. between N. 170th and N. 185th Streets. This district serves the local community and neighboring communities. The Hillwood/Richmond Beach commercial area is located on N.W. 185th Street and 8th Avenue N.W. It serves the City's northwest neighborhoods including Hillwood, Richmond Beach, Richmond Highlands, and Innis Arden. The Ridgecrest Business District is located at 145th Avenue N.E. between 15th Avenue and Lake City Way N.E. It serves the City's southeast neighborhoods including Ridgecrest and Briarcrest.

Community Institutions

Located on an 80-acre site on 15th Avenue N.E. and N.E. 155th Street, the Fircrest Campus is Shoreline's largest public institution. It is owned by several state agencies that administer the site (in part as trust lands) for the State of Washington. Presently, Fircrest School, located on the campus, is home to approximately 300 developmentally disabled citizens and is run by the Department of Social and Health Services (DSHS). Other separate campus uses include the Washington State Department of Health laboratories; Food Lifeline (the wholesale distributor of food to the food banks); and Washington State Patrol offices.

The City also has a significant number of private institutions including the Northwest School for Hearing Impaired Children, Shoreline Center, CRISTA

Ministries, as well as several private elementary and secondary schools, churches and other religious facilities, group homes and cemeteries.

Employment

Approximately 14,000 jobs existed in the City at incorporation. Of these jobs, approximately 40% were in the service sector, 29% were in the education and government sector, 27% were in the retail sector and 4% were in the manufacturing, wholesale, transportation, communications and utilities sectors.

Most of these jobs are located along Aurora Avenue, however, other employment clusters include the Shoreline Community College, the Fircrest Campus and neighborhood business centers in North City, Richmond Village, 5th Avenue N.E. and N.E. 165th Street, and 15th Avenue N.E. and N.E. 145th Street

Major employers within the community include:

- Shoreline Community College
- Fred Meyer
- Costco
- State Department of Transportation
- Sears
- Marshall's
- Home Depot
- CRISTA Ministries
- Shoreline School District
- Fircrest
- City of Shoreline

According to the 2000 census, 28,144 City residents over age 16 were employed in the region, most in the management and professional sector (40.2%) followed by sales and office occupations (26.7%), service occupations (14.5%), production and transportation occupations (10.2%), construction and maintenance occupations (8.1%) and farming and fishing occupations (0.2%).

DEMOGRAPHICS

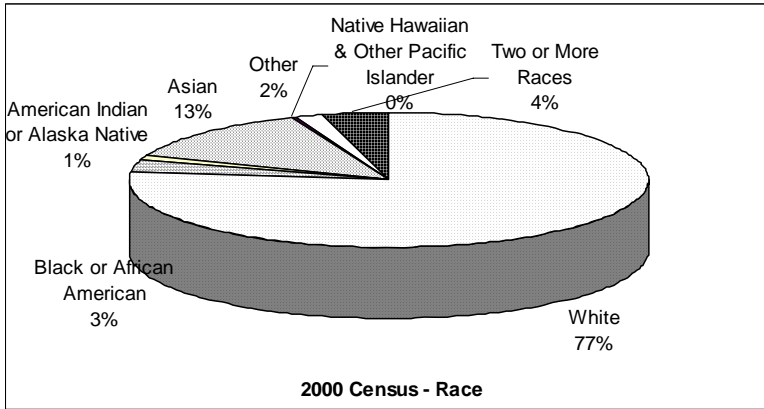

2000 Census - Age Distribution of Residents

Age Group	Count	Percentage
Under 5 years	2,769	5.2%
5 to 9 years	3,268	6.2%
10 to 14 years	3,662	6.9%
15 to 19 years	3,485	6.6%
20 to 24 years	2,844	5.4%
25 to 34 years	6,782	12.8%
35 to 44 years	9,329	17.6%
45 to 54 years	8,641	16.3%
55 to 59 years	2,605	4.9%
60 to 64 years	1,926	3.6%
65 to 74 years	3,601	6.8%
75 to 84 years	2,888	5.4%
85 years and older	1,225	2.3%
Total	53,025	100.0%

2000 Census - Types of Housing Units

Housing Unit Type	Count	Percentage
Single Family-Detached	15,262	71.6%
Single Family-Attached	508	2.4%
Duplex	394	1.8%
3 or 4 units	516	2.4%
5 to 9 units	622	2.9%
10 to 19 units	1,037	4.9%
20 or more units	2,802	13.1%
Mobile home	170	0.8%
Boat, RV, van, etc.	19	0.1%
Total	21,330	100.0%

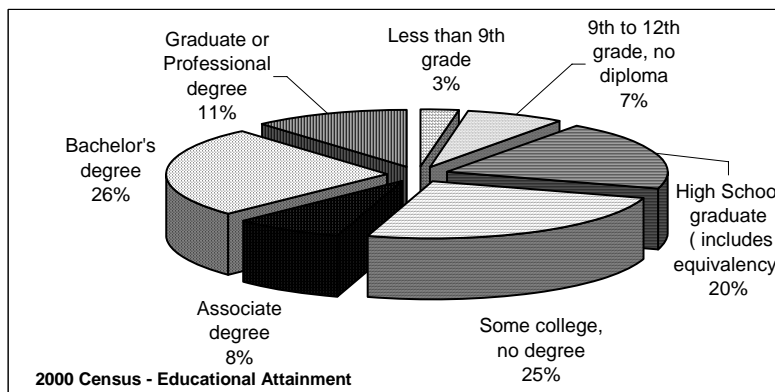
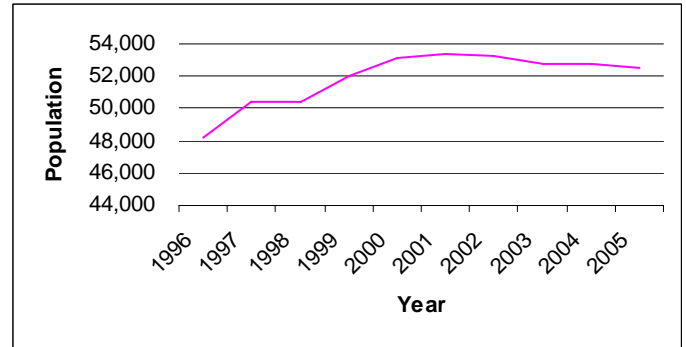

COMMUNITY SERVICES

Police Services

- Shoreline Police Department (Contracted from King County Sheriff's Office)
- Shoreline Police Station
- Eastside Neighborhood Center
- Westside Neighborhood Center

Fire Services

Shoreline Fire District #4

- Fire District Headquarters/Station 61
- Fire Station 63
- Fire Station 64
- Fire Station 65

Court Services

- King County District Court – Shoreline Division

Recreation Facilities

- Richmond Highlands Recreation Center
- Shoreline Pool
- Spartan Gym
- Annex Teen Center

Library Services

King County Library District

- Shoreline Library
- Richmond Beach Library

Utility Services

- Cable: Comcast
- Electricity: Seattle City Light
- Garbage/Recycling: Waste Management
- Natural Gas: Puget Sound Energy
- Sewer: Ronald Wastewater District
- Water: Seattle Public Utilities
Shoreline Water District
- Telephone/Cellular: Various

MAP SHOWING SHORELINE'S PARKS AND RECREATION CENTERS

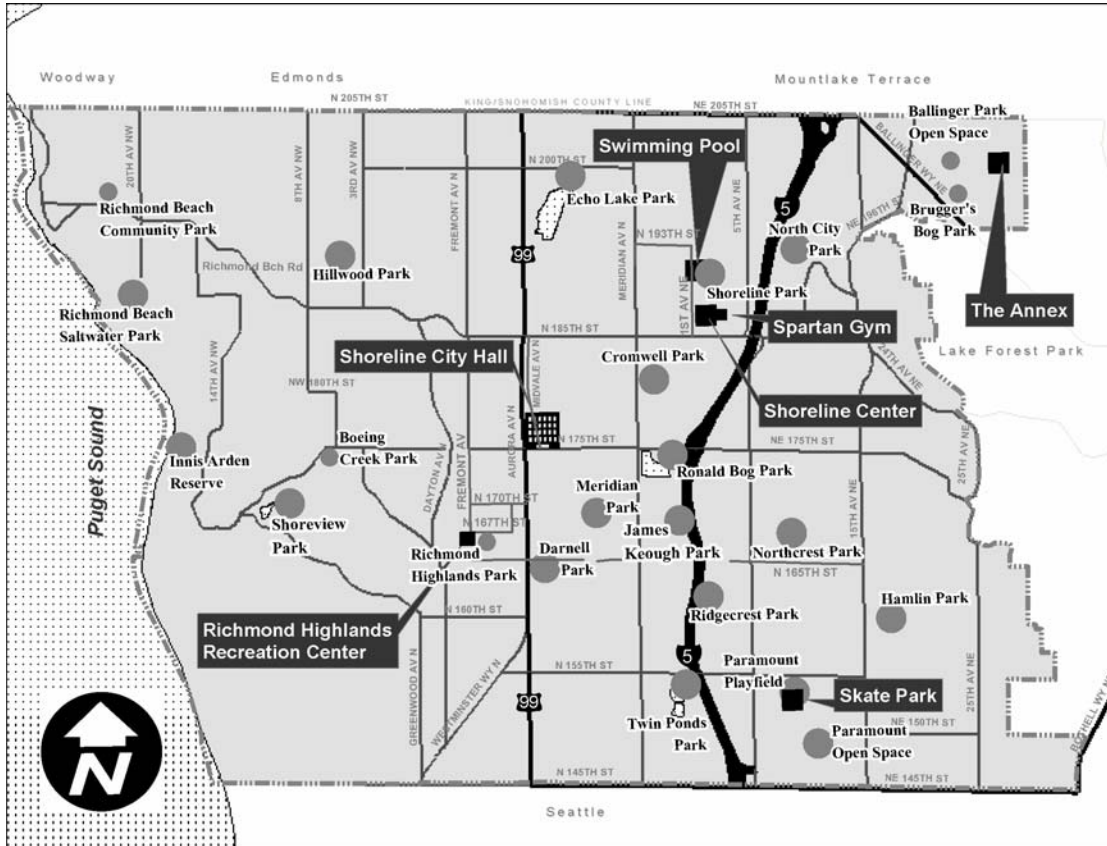

PARKS FACILITIES AMENITIES

Park Facility	Restrooms	Play-ground	Basketball	Soccer	Tennis	Handball	Baseball	Hiking	Swimming	Waterfront	Picnic Areas	Fishing
Ballinger Open Space								✓				
Boeing Creek								✓		✓		
Brugers Bog		✓						✓			✓	
Cromwell		✓	✓	✓			✓					
Echo Lake	✓									✓		✓
Hamlin Park	✓	✓					✓	✓			✓	
Hillwood	✓	✓		✓	✓		✓					
James Keough		✓	✓	✓								
Meridian Park			✓		✓			✓				
North City								✓				
Northcrest		✓						✓				
Paramount Park Open Space								✓				
Paramount Playfield	✓	✓		✓			✓	✓			✓	
Richmond Beach Community Park	✓	✓			✓							
Richmond Beach Saltwater Park	✓	✓						✓		✓	✓	✓
Richmond Highlands Park	✓	✓	✓				✓					
Ridgecrest Playfield		✓				✓	✓					
Ronald Bog										✓	✓	
Shoreline Park	✓	✓		✓	✓			✓		✓		
Shoreline Pool									✓			
Shoreview Park	✓	✓		✓	✓		✓	✓				
Twin Ponds	✓	✓		✓	✓			✓		✓	✓	

BUDGET PROCEDURES AND PROCESS

Operating Budget Procedures and Amendments Process

The City's budget procedures are mandated by Chapter 35A.33 of the Revised Code of Washington. The budget, as adopted annually by the City Council, constitutes the legal authority for expenditures. The budget covers the fiscal year from January 1st to December 31st. The City's budget is adopted at the fund level. Expenditures during the year may not legally exceed the total appropriation within any specific fund.

Budgets are appropriated and adopted for all of the City's funds. All fund budgets, with the exception of the capital funds, are adopted on an annual basis. Calendar year budgets are adopted by the City Council for the General Fund, Special Revenue, Capital, and Internal Service funds. Total project budgets are approved by the City Council when the six-year Capital Improvement Plan (CIP) is adopted. However, budgets for the capital funds are appropriated annually for that year's portion of each capital project. For operating funds, all appropriations lapse at year-end. Programs or projects that need to continue into the following year can be included in the annual re-appropriation process. This process allows budget authority to be carried forward into the new fiscal year for any commitments that have been made for purchases or contracts that were not completed in the prior year.

Budget Transfers and Amendments

The City Manager is authorized to transfer appropriations during the fiscal year, between department and programs within the same fund. However, any revisions that change the total expenditures of a fund or that affect the number of authorized employee positions, salary ranges, hours, or other conditions of employment must be approved by the City Council. The budget is typically only amended during the year to provide for new grant or other revenue sources or for program developments and new opportunities that occur outside of the timing of the typical budget process.

Basis of Accounting

Basis of accounting refers to when revenues, expenditures, expenses, transfers and the related assets and liabilities are recognized, recorded and reported in the financial statements. The full accrual basis of accounting is used for proprietary or internal service funds. This includes the Surface Water Utility Fund, Vehicle & Operations Fund, Equipment Replacement Fund and the Unemployment Fund. Under this method, revenues are recognized when earned, and expenses are recognized when incurred.

The modified accrual basis of accounting is used by governmental, expendable trust and agency funds. This includes all other City funds. Revenues and other financial resources are recognized when they become susceptible to accrual, i.e., when the related funds become both measurable and available to finance expenditures of the current period. To be considered "available", revenue must be collected during the period or soon enough thereafter to pay current liabilities. For example, property taxes and other taxpayer assessed revenues due for the current year are considered measurable and available and therefore as revenues even though a portion of the taxes may be collected in the subsequent year. Licenses, fines, and miscellaneous revenues

BUDGET PROCEDURES AND PROCESS

are recorded as revenues when they are received in cash because this is when they can be accurately measured. Investment earnings are accrued as earned. Expenditures are considered as a liability when they are incurred. Interest on long-term debt, judgments and claims, and compensated absences are considered as a liability when they are paid.

Basis of Budgeting

In some cases, the City prepares the annual budget using a different basis than is used for accounting. The budgeting basis differs by fund type. Budgets are prepared for Governmental Funds (General Fund Street Fund) on a modified accrual basis and can be directly compared to the fund operating statements in the City's annual financial report. The Surface Water Utility Fund and the Internal Service Funds are budgeted on a modified accrual basis and are depicted in the operating statements using an accrual basis; therefore these funds are not directly comparable.

The Annual Operating Budget Process

The budget process is a continuous cycle that includes the following phases of budget development and monitoring: City Council's Annual Planning Retreat, Leadership Team's Annual Planning Retreat, City Manager's Proposed Budget, City Council budget review and formal adoption, ongoing monitoring of expenditures and revenues, and any required budget adjustments/amendments due to additional revenues or new opportunities.

The City typically utilizes an incremental budgeting approach that assumes, for most functions of government, that the current year's budget is indicative of the base required for the following year. Any increases are incremental and based on need as defined by the organization's budget policies, emerging issues, Council goals, and available resources.

This incremental process recognizes that most mandated functions will not likely change from year to year. Therefore, the major emphasis of the budget analysis and decision-making is focused around Council priorities and requested increases in funding rather than ongoing mandated functions.

The budget development phase begins in April with the Council Planning Retreat. During the retreat, the City Council reviews the City's Long-term (six-year) Financial Plan to determine the City's financial condition. Every other year, the City surveys its citizens to gather their priorities. During the retreat, the Council establishes their priorities for the upcoming year using input from the citizen survey and various advisory boards. The City's strategic plan and the Council's annual work plan are updated to reflect the Council priorities.

In May, the Annual City Leadership Team Planning Retreat is held. During this retreat, the City's current financial condition is reviewed to determine the amount of available

BUDGET PROCEDURES AND PROCESS

funding. Emerging issues are identified and prioritized based on the City's strategic plan and the Council's annual work plan.

During June, the Finance Department conducts a formal training process for the departments to explain the budget instructions, the budget preparation system, and to answer any questions prior to the departments beginning their base budget development.

In June and July, the departments develop their base budgets and prepare requests for new staff, programs, or significant increases to their current year budget that will address emerging issues and other operational needs. In their requests, the departments identify the problem that they are trying to address, the recommended solution, implementation plan, projected cost and expected outcomes. The Finance Department conducts an analysis of the departmental base budgets and the revenue outlook for the coming year to determine the availability of funds for any new initiatives. These budget requests are submitted to the Finance Department by the end of July.

In August, the Finance Department meets with each of the departments to discuss their current budget, new Council goals, year-end projections, emerging issues and priorities, and their budget requests for the next fiscal year.

In late August or early September, the City Manager meets with each department to review their budget requests. In September, the City Manager develops preliminary budget recommendations and presents an update to the City Council of the status of the proposed budget.

Based on City Council policy and program input, the City Manager and Finance staff finalize the City Manager's Proposed Budget and present it to the City Council in late October. This Proposed Budget is made available to the public in the City's libraries, City Hall, and at Council meetings and workshops.

During the months of October and November, the City Council holds workshops on the proposed budget to receive input from the public and budget presentations from City departments, to discuss priorities and options, and to make final adjustments and decisions on the budget.

Also in October and November, the City Council holds two formal public hearings, one on the setting of the annual property tax levy and one on the next year's budget. Following these hearings, the City Council adopts the property tax ordinance and the annual budget.

After the budget is adopted, the City enters the budget implementation and monitoring phase. Throughout the year, expenditures are monitored by the Finance Department and department directors to ensure that funds are used as intended. Finance provides quarterly financial updates to the City Council to keep them current with the City's

BUDGET PROCEDURES AND PROCESS

financial condition. Any budget amendments made during the year are adopted by a City Council ordinance.

Once the fiscal year begins, budget amendments may be required to increase adopted appropriation levels. In February, departments may request to carryover committed funds from the prior year to be used to complete operating or capital project work that is not included in the new fiscal year budget. These requests may be included in the re-appropriation budget ordinance that is presented to the City Council in March.

The Capital Improvement Plan is updated and adopted each year in July. The plan can contain changes to project budgets in the current year. Therefore, a budget amendment may be presented to the City Council along with the CIP to revise the project appropriations.

Throughout the year, as circumstances requires, other budget amendments may be presented to the City Council to address issues that arise outside of the normal budget process.

The Annual Capital Improvement Plan Process

Each year the City Council adopts a six-year Capital Improvement Plan. The annual CIP process begins in February. The status of current projects and funding sources is reviewed. Adjustments to estimated costs and project timing are made as necessary. Estimated project costs for future years are based upon current year cost plus estimated inflation. Future grant revenue estimates are based upon anticipated funding requests to granting agencies. Revenue estimates may be adjusted as more concrete information is received on specific grant awards.

In February, departments also begin to develop requests for new capital projects for inclusion in the upcoming Capital Improvement Plan. Proposed projects are developed in conjunction with the City Council priorities and input from citizens and City advisory boards. In 2005, the City Council adopted master plans for transportation, surface water facilities, and parks, recreation and open spaces. These plans identify problems, prioritize needs and develop long-term solutions that are in line with community priorities and City resources. In the future, the master plans will guide the development of the six-year Capital Improvement Plan.

In April, departments complete their CIP project updates and new requests and submit them to Finance for review. Once Finance completes its review, the proposed CIP is presented to the CIP Coordination Team. The CIP Coordination Team reviews and prioritizes the proposed CIP and submits a recommended CIP to the City Manager. The Team evaluates projects and selects those with the highest priority based on input from citizens, project stakeholders, advisory committees and City Council goals.

BUDGET PROCEDURES AND PROCESS

The City Manager finalizes the proposed CIP in May for submittal to the City Council in early June. The Council holds a public hearing to receive public comment on the proposed CIP and adopts the CIP in July.

An appropriation for the first year of the adopted CIP is included in the 2007 proposed budget. This first year appropriation may be modified from what was included in the adopted CIP if changes occur in the City's financial condition during the interim period or as projections are finalized. The City Council adopted the 2007-2012 Capital Improvement Program (CIP) in July of this year. The total 2007-2012 CIP is \$158.9 million. The 2007 budget for facilities, parks, and transportation is approximately \$31 million. Surface water capital expenditures for 2007 total \$3.9 million and are budgeted within the Surface Water Utility Fund.

**City of Shoreline
2007 Budget Calendar**

BUDGET PROCESS DESCRIPTION	Feb.	Mar.	Apr.	May	June	July	Aug.	Sep.	Oct.	Nov.
Capital Improvement Process Begins										
Council Planning Retreat										
Departments Submit CIP Project Updates and Requests for New Projects										
Finance Reviews New CIP Project Requests and Potential CIP Funding Sources										
Finance Develops Initial 2007 Revenue Forecast										
Leadership Team Budget Retreat										
CIP Coordination Team Reviews CIP										
Finance Staff Provides Budget Training Session and Delivers Base Budget Targets										
Proposed 2007 – 2012 CIP Presented to Council										
Public Hearing on Proposed 2007 – 2012 CIP										
2007 – 2012 CIP Adopted by Council										
Departments Submit Current Year-End Projections, 2007 Budget Requests, and 2007 Service Package Requests										
Finance Updates 2007 Revenue Estimates										
Finance Reviews Department Requests for Funding and Meets with Each Department										
City Manager Meets with Department Staff to Review Their Budget Proposals										
City Manager Makes Specified Adjustments to Department Submittals/Establishes Preliminary Budget										
2007 Proposed Budget Update to City Council										
Preliminary Budget Document Prepared, Printed and Filed With City Clerk and Presented to the City Council (at Least 60 Days Prior to the Ensuing Fiscal Year)										
City Council Conducts Workshops and Public Hearings on the Preliminary Budget										
Council Holds a Public Hearing on the 2007 Property Tax Levy and Adopts the 2007 Property Tax Levy										
Preliminary Budget Modified per Council Direction										
Final Budget Adoption										

GENERAL BUDGET POLICIES

(Excerpted from the City's Financial Policies, which can be found in the Appendix of this document.)

These general budget policies are the basis on which staff develops budget recommendations and establishes funding priorities within the limited revenues the City has available to provide municipal services.

- No Operating Deficit (*Balanced Budget*): Current revenues will be sufficient to support current expenditures. Revenue estimates will be realistic and debt financing will not be used for current operating expenses.
- Resources Greater than Budget Estimates: Resources (fund balance) greater than budget estimates in any fund shall be considered "one-time" resources and shall not be used to fund ongoing service delivery programs.
- Budget Adoption Level: Budget adoption by the City Council shall be at fund level. Any changes in appropriations at fund level require City Council approval.
- Necessary to Implement City Council Goals Identified in Annual Workplan: The City Council identifies specific goals as part of its work-plan, and departmental budgets should include adequate resources to accomplish those goals in the expected timeframes.
- Public Safety Protection: Public safety is a top priority, and as such, unmet needs in this area should have a priority over other service areas.
- Degradation of Current Service Levels: When increased service demands are experienced over a sustained period of time, resources should be provided to prevent service level degradation below an acceptable level.
- Investments that are Primarily Funded by Additional Fees or Grants: Programs and investments that are funded through a dedicated revenue source (i.e., non-tax revenue), that meet the goals of the City Council, will receive priority consideration.
- Investments that Delay Future Cost Increases: When practical, resources should be allocated for selective preventative investments that can be made to avoid even larger costs in the future.
- Investments that Forestall Adding Permanent Staff: Recognizing that personnel related expenditures represent the largest portion of the City's budget, methods to increase efficiency and effectiveness of the delivery of City services through technology improvements should receive priority funding if it can forestall the addition of permanent staff.
- Commitments that can Reasonably be Maintained over the Long-Term: Funding for new programs and services in operating funds should be limited to the extent that they can be reasonably funded over the near-to-long-term given the current revenue stream.
- Overhead and Full Cost Allocation: Department budgets should be prepared in a manner to reflect the full cost of providing services.

- Maintenance of Quality Service Programs: The City of Shoreline will offer quality service programs. If expenditure reductions are necessary as a result of changing economic status, selective service elimination is preferable to poor or marginal quality programs that are caused by across the board cuts.
- Distinguished Budget Presentation: The City will seek to comply with the suggested criteria of the Government Finance Officers Association in producing a budget document that meets the Distinguished Budget Presentation program criteria as policy document, as an operations guide, as a financial plan, and as a communication device.



Vision

A community of families, safe neighborhoods, diverse cultures, active partnerships, quality businesses, natural resources and responsive government

Values

- **Strong neighborhoods, citizen partnerships and active volunteers**
- **Social, cultural and economic diversity**
- **Human service connections and networks**
- **Open, efficient, participatory government**
- **Community and regional leadership and collaboration**
- **Sustainability and stewardship of the environment and natural resources**
- **Quality educational, recreational and cultural opportunities for all ages**

Strategic Objectives

- **Safe and attractive neighborhoods and business districts**
- **Quality services, facilities and infrastructure**
- **Human Services**
- **Safe, healthy and sustainable environment**
- **Economic vitality and financial stability**
- **Governmental excellence**
- **Effective citizen communication and engagement**

CITY COUNCIL WORK PLAN

2007-2008

Goal No. 1

Complete the projects approved in the 2006 Parks Bond

Goal No. 2

Implement the Economic Development Strategic Plan

Goal No. 3

Implement an affordable civic center/city hall project

Goal No. 4

Complete the Aurora improvements from 165th to 205th Streets including, but not limited to, sidewalks, drainage and transit

Goal No. 5

Develop a comprehensive housing strategy



Goal No. 6

Create an "environmentally sustainable community"

Goal No. 7

Provide safe and affordable transportation options to support land use plans including walking, bicycling, transit and vehicular options

Goal No. 8

Develop a Fircrest master plan in partnership with the state

Goal No. 9

Increase emergency preparedness training and education

Goal No. 10

Increase opportunities for all residents, including our youth, to get more involved in neighborhood safety and improvement programs



CITY COUNCIL WORKPLAN 2007-08

Goal No. 1: Complete the projects approved in the 2006 Parks Bond

- Acquire bond issue properties
- Develop park plans
- Construct improvements

Goal No. 2: Implement the Economic Development Strategic Plan

- Implement Small Business Assistance Plan
- Work to redevelop Aurora Square/Westminster
- Facilitate planning for 175th/Aurora properties
- Develop Ridgecrest Neighborhood plan

Goal No. 3: Implement an affordable civic center/city hall project

- Adopt delivery method, public process and schedule
- Select development team and negotiate agreement
- Finalize design and development agreement

Goal No. 4: Complete the Aurora improvements from 165th to 205th Streets including, but not limited to, sidewalks, drainage and transit

- Finalize preliminary design and environmental review
- Complete final design
- Initiate right-of-way acquisition

Goal No. 5: Develop a comprehensive housing strategy

- Develop workplan and citizen involvement process
- Finalize alternative strategies
- Complete draft plan
- Review and adopt final strategies

Goal No. 6: Create an “environmentally sustainable community”

- Develop a Natural Resources Management Plan
- Complete Forest Management Plan
- Develop options for a Green Street Demonstration Project
- Adopt advanced stormwater standards for Aurora II
- Update Stormwater Management Manual and standards
- Work on implementing Mayor’s Climate Protection Agreement



Goal No. 7: Provide safe and affordable transportation options to support land use plans including walking, bicycling, transit and vehicular options

- Develop “Town Center” plan
- Continue construction of priority sidewalk routes
- Complete Neighborhood Traffic Action Plans and continue implementation
- Expand local transit service
- Develop Interurban Trail Connectors

Goal No. 8: Develop a Fircrest master plan in partnership with the State

- Develop agreement with State
- Complete draft plan
- Review and adopt final plan

Goal No. 9: Increase emergency preparedness training and education

- Develop public outreach campaign
- Provide emergency power for Spartan Rec Center shelter
- Provide federally mandated emergency management training
- Implement Hazard Mitigation Plan priority projects

Goal No. 10: Increase opportunities for all residents, including our youth, to get more involved in neighborhood safety and improvement programs

- Increase Block Watches
- Expand Adopt-a-Road, -Park and -Trail programs
- Provide Mini-Grants for neighborhood safety and preparedness
- Provide increased opportunity for youth safety involvement

Community participation is a critical value in both the development and implementation of Council Goals and Workplans. For information on how you can be informed and involved in any of these goals please visit the City of Shoreline Web site at www.cityofshoreline.com and click on the City Council Goals.



TRANSMITTAL LETTER



October 16, 2006

Honorable Mayor, City Council, and Shoreline Residents:

I am pleased to present the 2007 Proposed Budget. This document presents the overall plan for allocating the resources of the City to a variety of programs necessary to keep the community safe, enhance the quality of life, and maintain and develop quality facilities, parks, roads, and storm drainage systems.

The City of Shoreline is in excellent financial condition. This condition has intentionally been obtained as a result of the prudent financial policies adopted by the City Council and the implementation of those policies with fiscally constrained budgets. To date, the City has been able to maintain service levels for existing programs and increase maintenance levels as street and park capital projects have been completed within existing revenue sources. Although we have been able to maintain our service levels, and in some cases improved service levels, both our near-term and long-range forecasts indicate that this will become more challenging, as the City's revenue growth is anticipated to be below the projected inflation and expenditure levels for the next several years.

In preparing this budget, it was my goal to allocate our resources to provide services that support "Shoreline Strategic Directions" for 2007-08. Consistent with Council direction and input, the budget places primary emphasis on maintaining current services, investing in capital projects to enhance the facility, transportation, surface water, and environmental systems throughout the City, and implementing programs to enhance the economic development, health and sustainability, and human service programs within our community.

Budget Highlights

The City's 2007 proposed budget is balanced in all funds and totals \$68.2 million. The 2007 proposed budget is \$21.4 million or 23.9% less than the current 2006 Budget. This is primarily a result of the 2007 capital budget being \$22.5 million less than the 2006 capital budget. The decrease in capital expenditures is a result of the near completion of the Aurora Avenue Improvements from 145th to 165th and the completion of the North City Business District/15th Avenue improvements. The Civic Center project and the parks bond related projects remain as the most significant capital projects that will occur in 2007.

The following table summarizes the 2007 budget and provides a comparison to the 2006 current budget by fund. The 2006 budgeted expenditures represent the adopted budget and any budget amendments, such as reappropriations, that have occurred in 2006 through September.

Fund	2007 Proposed Budget			2006 Current Budget	
	Beginning Fund Balance	Revenue	Expenditures	Ending Fund Balance	Budget Expenditures
Operating Funds:					
General Fund	\$ 7,394,350	\$ 27,775,480	\$ 28,426,981	\$ 6,742,849	\$ 29,398,166
General Reserve	2,282,647	58,546	0	2,341,193	0
Streets	795,243	2,302,087	2,422,087	675,243	2,559,651
Code Abatement	68,128	82,500	100,000	50,628	100,000
Asset Seizure	33,831	23,500	23,500	33,831	23,000
Sub-Total Operating Funds	10,574,199	30,242,113	30,972,568	9,843,744	32,080,817
Internal Service Funds:					
Equipment Replacement	1,470,072	315,569	100,000	1,685,641	138,180
Public Art Fund	212,240	0	0	212,240	115,775
Unemployment	72,258	10,500	10,000	72,758	10,000
Vehicle Operations & Maintenance	59,637	139,988	139,988	59,637	88,717
Sub-Total Internal Service Funds	1,814,207	466,057	249,988	2,030,276	352,672
Enterprise Funds:					
Surface Water Utility Fund	6,363,913	5,339,508	5,948,957	5,754,464	3,682,346
Sub-Total Enterprise Funds	6,363,913	5,339,508	5,948,957	5,754,464	3,682,346
Capital Funds:					
General Capital	12,232,990	14,930,580	23,691,223	3,472,347	18,951,460
City Facility-Major Maintenance Fund	177,152	77,972	110,000	145,124	60,000
Roads Capital	7,885,027	5,883,505	7,233,434	6,535,098	34,488,919
Sub-Total Capital Funds	20,295,169	20,892,057	31,034,657	10,152,569	53,500,379
Total City Budget	\$ 39,047,488	\$ 56,939,735	\$ 68,206,170	\$ 27,781,053	\$ 89,616,214

The Surface Water Utility Fund does not include the operating transfer that was originally included in the Surface Water Management Fund to the Surface Water Capital Fund. This transfer was eliminated when the two funds were consolidated. For this reason the 2006 Budget on this table is \$3,242,693 less than the actual adopted 2006 budget.

The budget can be divided into four parts: Operating, Internal Service, Enterprise and Capital. The City's operating budget represents the cost of providing services to the Shoreline Community on a day-to-day basis. The capital budget represents the cost of making improvements to the City's facilities, parks, and transportation systems. Internal service funds represent transfers between funds (Vehicle Operations, Equipment Replacement, and Unemployment) to fund maintenance and replacement of City equipment and unemployment claims. The enterprise fund consists of the operation and capital improvements of the surface water utility.

The 2007 operating budget supports current service levels along with some minor on-going service enhancements and one-time special projects. The operating budget totals \$31 million. The City's operating expenditures decreased by \$1,108,249 or 3.5%, when compared to the 2006 budget.

The 2006 operating budget included \$2.3 million in one-time transfers. Approximately \$1.65 million was to be used towards the purchase of property for the future Civic Center/City Hall, \$200,000 for traffic calming devices and the remaining \$450,000 was to provide funding for the rehabilitation of six to eight traffic signals during the next three years. This transfer was possible because revenues exceeded expenditures for the past five years in the General Fund resulting in annual surpluses. As these surpluses were considered one-time savings, the City's financial policies dictate that the savings should be expended for one-time expenditures. Currently staff is estimating that the General Fund will end 2006 with a \$7.4 million ending fund balance. This is approximately \$1.4 million greater than was anticipated when the 2006 budget was adopted. This was primarily because the 2006 beginning fund balance was \$9.68 million, or \$1.87 million more than originally projected.

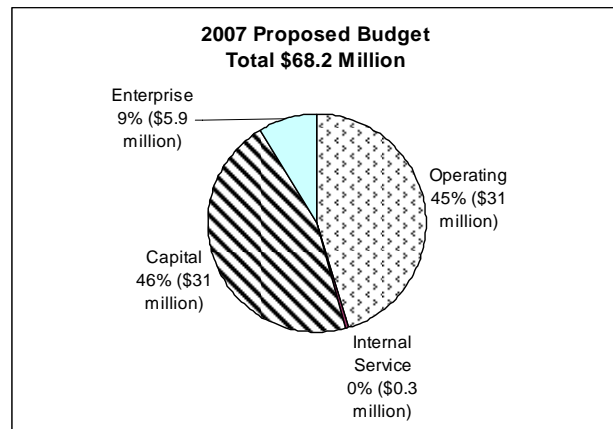

I have proposed in the 2007 budget that we use \$651,500 of the General Fund fund balance for one-time expenditures. The largest portion of this is the budgeting of \$505,000 for general budget contingencies and insurance reserves, per the City's adopted financial policies. In addition to the \$505,000, I am proposing to use \$146,500 for one-time investments. This includes \$100,000 that will be used to develop a Natural Resources Management Strategy (NRMS) in conjunction with Council Goal No. 6 - Create an "environmentally sustainable community"; \$30,000 to develop a Town Center Development Plan, and \$16,500 to purchase a truck for the new Parks Maintenance Worker position.

The projected 2007 General Fund ending fund balance is \$6.7 million. Combined with the projected \$2.3 million in General Reserve fund balance, total General Reserves will be approximately \$9 million, or 33% of budgeted General Fund revenue.

The preceding table reflects a 3.3% decrease in the General Fund budget for 2007. When comparing the 2007 budget to the 2006 budget, it is important to remember that the 2006 budget includes \$2.3 million in one-time expenditures and approximately \$613,000 in carry-over appropriations from 2005. If these items were eliminated from the 2006 budget and the \$146,500 in one-time appropriations were eliminated from the 2007 budget, the 2007 General Fund budget increased by 6.8%, \$1.8 million when compared to 2006. The most significant changes between the 2006 and 2007 General Fund budget will be discussed later in this letter.

The proposed 2007 General Fund budget has \$63,465 in unallocated resources. These monies have been placed in a contingency account. I am recommending that the City Council leave these monies in contingency because there are two significant items that could have additional budget impact on the City in 2007. The first would be an additional increase in the 2007 Washington State Public Employees Retirement System (PERS) employer contribution. When the 2006 Washington State Legislature established the long-term PERS employer contribution rates they did not address the funding for the gain-sharing provisions in PERS 1 and 3. On September 29, 2006, the Pension Funding Council set the proposed PERS employer contribution rates for the 2007-2009 biennium. The rates set by the Council included rate increases to fund the gain-sharing provisions and a phasing in of the unfunded PERS 1 liability. As a result, the rates set by the Council are 0.64% greater than those adopted by the Legislature in 2006. It is unclear at this time whether the 2007 Legislature will adopt the rates set by the Council or modify them in some manner. If the Legislature adopts the Council's rates, then the City's PERS contributions will increase an additional \$31,000 in 2007.

The second item that may have a negative budget impact to the City in 2007 is the proposed Seattle City Light (SCL) rate increases for street lights. At this time it is estimated that the proposed rate increases could result in increased costs, beyond those in the 2007 budget, to the City ranging from \$40,000 to \$120,000. The primary reason for the range is that staff and SCL are still trying to reconcile the SCL inventory of street lights so that the City has a comprehensive billing inventory of the street lights in Shoreline.

The \$63,465 in contingency would not be sufficient to fund both the street light increase and the PERS rate increase in a worse case scenario, but it would fund a significant portion if the need arises.

From 2006 to 2007 the City's capital expenditures are projected to decrease by \$22.5 million, or 42%. The capital budget includes resources that are allocated for completion of projects that enhance the City's facilities, parks, and transportation systems.

Major changes within the City's 2007 budget include the following:

- ◆ **Personnel Costs:** The 2007 budget includes an increase of \$991,310, 8.4%, in personnel costs. This table summarizes the changes with a more detailed explanation following.

	2006 Budget	New Positions	Position Adjust.	Extra-Help Budget Change	Vacation Buy-Out	Step Increases	Market Adjust.	Retirement, L&I and Health Premium Changes	2007 Budget	% Change
Salaries	9,266,184	51,510	(22,997)	33,362	(20,000)	147,642	341,830		9,797,531	5.7%
Benefits	2,493,062	19,553	(1,733)	-		17,709	41,001	383,430	2,953,022	18.4%
Sub-Total	11,759,246	71,063	(24,730)	33,362	(20,000)	165,351	382,831	383,430	12,750,553	8.4%
Budget Reductions/New Revenues		(95,326)		(30,000)					(125,326)	
Net Budget Impact	11,759,246	(24,263)	(24,730)	3,362	(20,000)	165,351	382,831	383,430	12,625,227	7.4%

- ◆ The major changes in personnel costs include a combination of the following:
 - Salaries and wages are increasing by \$531,352 or 5.7% in 2007. Increases to salaries and wages include:
 - New employee positions account for 9.7% of the increase in budgeted salaries. (\$51,510, net budget impact is savings of \$24,263): The proposed 2007 budget includes a recommendation to increase the City's regular employee full time equivalents (FTE's) by a net 1.25 FTEs. The proposed position changes include:
 - Increasing the Finance Technician in the Purchasing Services program from a 0.625 FTE to a 0.75 FTE (\$5,842)
 - Increasing the Finance Technician in the Financial Planning and Accounting Services program from a 0.50 FTE to a 0.625FTE (\$5,337)
 - The addition of a Parks Maintenance Worker II for the Athletic Field Maintenance and Operations programs (\$40,331)
 - All of these changes were off-set by expenditure reductions
 - In 2006 the City implemented a new vacation buy-out program. The budget for this was estimated at \$50,000. Based on current experience the 2007 budget has been lowered to \$30,000, resulting in a \$20,000 reduction.
 - Market salary adjustments and budgeted step increases. The budget includes an overall 3.78% market adjustment for all regular personnel classifications (\$341,830) and anticipated step increases for eligible employees (\$147,642); and
 - Reductions as a result of changes in organizational structure, such as in the City Manager's Office, with the elimination of the Deputy City Manager position and the addition of a second Management Analyst position.
 - Increase of budgeted extra-help (\$33,362) primarily related to performing athletic field maintenance work with extra-help as opposed to a contract service. \$30,000 of this increase was off-set by a reduction in contract services.
 - Projected benefit cost increases (\$459,958) are related primarily to the following:
 - Proposed position changes discussed in the previous section increase benefit costs by \$19,553.
 - Health benefit costs are projected to increase by \$124,000, 8.8%.
 - Increases in the employer contribution to the City's Social Security program, Washington State Retirement System and Medicare, for existing positions, will increase by \$58,710 as a result of the recommended market adjustment and anticipated salary step increases.
 - Increases in rates for workers compensation will result in an increase of \$9,900 cost for labor and industry premiums.
 - The Washington State Public Employees Retirement System (PERS) employer contribution rate will go from 3.69% to 5.46% effective January 1, 2007. A second rate increase will occur on July 1, 2007, with the rate increasing either to 6.01% or 6.64% depending on the State Legislature's decision whether to adjust the rate to include the PERS 1 and 3 gain-sharing provisions and the unfunded PERS 1 liability. The 2007 Proposed budget used the 6.01% contribution rate for determining projected 2007 PERS costs. As stated earlier in this letter, the 2007 budget has some monies in contingency if the rate is set at 6.64%. Based on the increase to 5.46% on January 1st and the second increase to 6.01% on July 1st,

- the 2007 budget reflects increased retirement contribution costs of \$252,326, a 96% increase when compared to the 2006 budget. It is projected that the contribution rate will continue to increase over the next several years.
- The City's compensation policy establishes salary ranges that are set at the median of the City's comparable organizations. As was approved in 2005, the City reviews one-third of the City's classifications annually, ensuring that all classifications are reviewed once every three years. In 2006 the City reviewed classifications 1 through 45. Based on the findings of this survey, the 2007 proposed budget includes \$30,000 in contingency to cover the anticipated salary schedule changes.
- ◆ **Police Contract:** Overall, the City's cost for police services is projected to increase by \$445,510 (5.5%) when comparing the estimated 2007 cost to the City's 2006 budget. This is primarily a result of increased personnel costs within the King County contract , an increase in the City's share of activity based cost allocations such as the 911 Communications Center, increases related to the operational costs of the County's wireless computer program, and the final \$25,000 annual COPS grant credit received in 2006.
- The contract with King County provides that the Sheriff's Office give an estimate of the 2007 costs by September 2006, and then reconcile this cost with the budget adopted by the County in March of 2007. Whichever cost is less is the amount that the City will actually pay. As a result of this process, it is not unusual that the City's budget may be slightly different from the actual annual contract with King County. This is the case in 2006. The amount budgeted for 2006 was more than the actual contract obligation for 2006, resulting in budget savings. The budget savings estimated for 2006 projected at \$100,000.
- ◆ **Jail:** The City's 2007 jail costs are expected to increase substantially, approximately \$386,217 or 46%, over the 2006 budget, but only \$25,217 over the projected 2006 expenditure level. This is primarily related to an increase in the number of jail bed days being used at all facilities.
 - ◆ **Human Service Funding:** The 2006 budget included an \$83,000 increase in the base General Fund budget for human service agencies. The 2007 budget includes an additional \$10,000 increase in General Fund allocation. I am aware that the Council has a desire to provide more funding in this area, but at this time, I believe that this is the level of funding we can sustain within the General Fund. As the Council considers additional revenue options in the future, the Council may want to consider how some of those revenues could be used to support the City's human service needs.
 - ◆ **2006 Base Budget Adjustments:** The 2006 budget contains approximately \$3 million in either one-time expenditures or 2005 carry-over expenditures. These items were removed while preparing the 2007 budget. In addition to these base adjustments, staff reduced the 2007 operating base budget expenditures by \$169,000 in order to balance the 2007 budget. These reductions were made in areas where the City has under expended budgeted amounts during 2004 through 2006. The following table highlights these base budget reductions:

<i>Department</i>	<i>Division</i>	<i>Line-Item</i>	<i>Amount</i>
Parks	Operations	Extra-Help	24,456
Public Works	Traffic Services	Professional Services	16,800
Comm & Intergovt Relations	Communications	Professional Services	17,500
Parks	Operations	Water	10,000
City Manager's Office		Professional Services	7,000
Finance	GIS	Professional Services	5,000
Finance	General Admin	Transfer Out to Abatement Fund	20,000
Customer Response Team		Professional Services	1,300
City Attorney		Professional Services	15,000
Economic Development		Professional Services	30,000
City-Wide		Vacation Buy-Out	20,000
Planning	Long-Range	Professional Services	2,000
		Total	<u>169,056</u>

- ◆ **Budgeted Contingency Expenditures:** The 2007 budget includes two main types of budgeted contingencies: operational and insurance contingency and other anticipated cost increases. These contingency accounts total \$598,465. The largest contingency is the operational and insurance contingency. Per the City's financial policies, these contingencies total \$505,000 and are funded by allocating a portion of the existing General Fund Balance. Other budgeted contingencies include a contingency for future PERS contribution increases or SCL street light rate increases in the amount of \$63,465. Since any increases in these areas will be on-going costs, reserving \$63,000 as a contingency only serves as a way to prevent these monies from being programmed into other on-going obligations. The remaining \$30,000 in contingencies will fund the anticipated salary changes related to the 2006 salary survey.
- ◆ **Liability and Property Insurance Assessment:** The City's liability and property insurance assessment will increase by \$50,442 from 2007 to 2006. This is approximately a 13% increase. The City's insurance assessment is determined by a combination of 5 year loss rate and worker hours. The City's work hours increased by 2.5% from 2004 to 2005, which is the time period used to determine the 2007 assessment. The City's 5 year loss rate actually improved from 2004 to 2005, but so did the overall group rating of agencies that are included within the City's risk management group. The overall 5 year loss rate improved by 11%. As a result the City's relative improvement was proportionately lower than the overall group improvement rating, resulting in a higher rate of risk still being applied towards the City's assessment determination.
- ◆ **Use of Operating Reserves:** The 2007 operating budget includes \$266,500 in one-time resource allocations. \$120,000 of one-time expenditures is included in the City Street Fund. Of this amount \$90,000, an additional \$60,000 is budgeted in the Surface Water Utility Fund, is allocated for the purchase of a street sweeper and \$30,000 for contract street sweeping as it is anticipated that it will take 3 to 4 months to receive the street sweeper. I am proposing that the City purchase a street sweeper and perform this task with internal staff, as opposed to external contracts. My recommendation is

based on the anticipated annual budget savings (\$42,000) and the improved environmental quality that we anticipate will occur with a regenerating street sweeper.

The City's General Fund includes \$146,500 in one-time expenditures. These funds will be allocated for the development of the Town Center Plan, Natural Resources Management Strategy, and a truck for the new parks maintenance worker position.

- ◆ **Lease Costs:** The 2007 budget reflects a significant decrease in lease costs as a result of the acquisition of the City Hall Annex. Since the City will own the building, there will be no lease costs for the space currently occupied by the City. There is also no debt service costs related to a new City Hall in 2007. Although this is the case, the 2007 budget includes a transfer of the lease savings (\$288,000) to the General Capital Fund in order to reserve those monies towards the acquisition of the Civic Center property and City Hall construction. Staff had estimated a total of \$350,000 of lease savings between 2007 and 2008 that would be allocated for this purpose. It is anticipated in 2009 that the annual reduction in lease payments would be used towards the annual debt service costs of the City Hall.

Staff is currently developing a management plan for the ownership of the Kimm Property and the City Hall Annex building. At this time, staff has not incorporated any lease revenue or operational expenses associated with these facilities outside of those related to the operation of City Hall into the 2007 proposed budget. This information will be presented to Council during the budget discussions and will be included in the 2007 adopted budget.

- ◆ **Surface Water Utility Fund:** The 2007 budget accurately reflects the accounting for the surface water utility (SWM) by budgeting for both the operational and capital components of the utility in a single fund.
- ◆ **Fee Changes:** The 2007 budget reflects the policy adopted by the City Council in 2000 to adjust development and recreation fees by the CPI-U for Seattle which is estimated at 4.2%. The 2007 fee schedule also includes a proposed \$9 annual increase in the City's surface water utility rate, bringing the annual residential rate to \$120. This rate adjustment was included in the surface water master plan adopted by the City Council in 2005. In 2007 the City will conduct a rate review process to identify any rate adjustments that will be needed over the next few years.
- ◆ **Capital Programs:** The City's 2007 capital budget reflects the first year of the City's adopted 2007-2012 capital improvement program (CIP).

More detailed information regarding changes within the 2007 budget can be found in the individual department sections of the budget.

Fiscal Capacity

As a City, we are challenged by our limited fiscal capacity. We are primarily a residential community, with 87% of our City assessed valuation in residential properties. We also have low sales tax revenue per capita, \$109, as compared to many other jurisdictions of a similar population. This is especially true with those jurisdictions that have much larger retail centers within their communities. The following chart shows a comparison of tax per capita with comparable cities:

Per Capita Comparison
 (Property Sales, B&O, Utility and Gambling Taxes, Franchise and Utility Contract Payments)

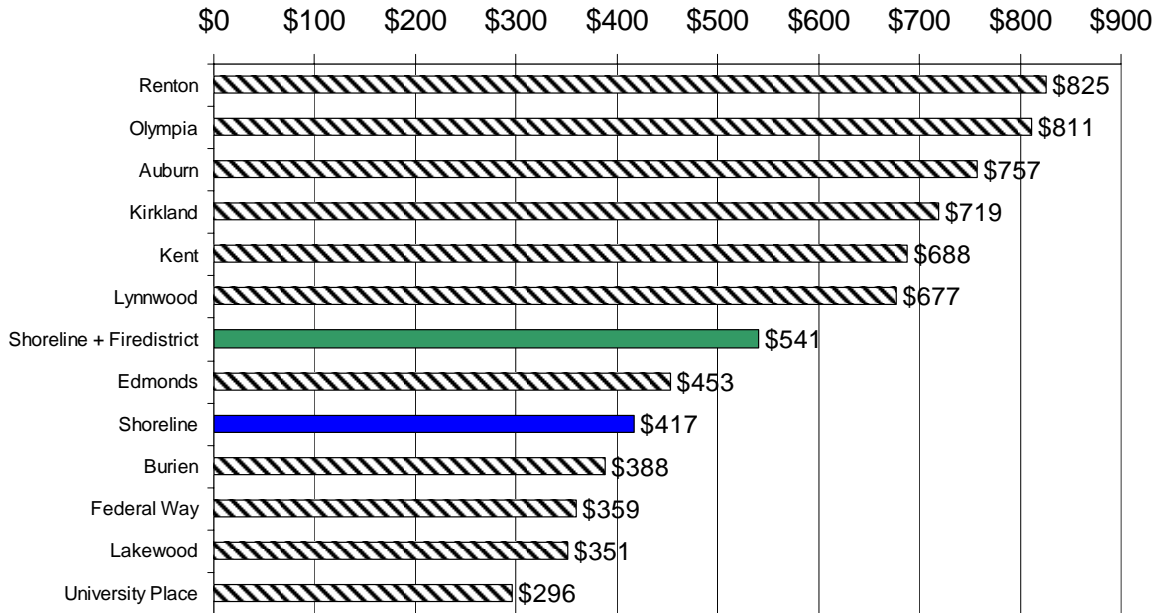

Some of these jurisdictions operate their own fire departments. If the City of Shoreline per capita tax collections included the Fire District’s property tax collections, the per capita tax collections would be \$541, still significantly below many of the other jurisdictions. Given this, we have been very conservative and prudent in our financial planning.

Economic Outlook & Revenue Growth

The long-term forecast for the Puget Sound Region economic growth remains positive. Although the U.S. economy as a whole is facing a slow down in the housing market and slower overall growth in the economy, economists are not predicting a recession, but rather slightly lower real Gross Domestic Product growth in 2007. Regionally economists project that job growth will slow from 3.8 percent in 2006 to 2.5 percent in 2007, still almost twice the U.S. pace. This will contribute to healthy income growth, sizable population gains, and a stable rate of homebuilding.

The long-term outlook is also positive. Between 2006 and 2016, employment is projected to rise at a 1.6 percent annual rate, slightly more than the national rate. This is expected to add over 300,000 jobs to the regional economy during this time period, and over half of those are projected to be added in King County.

Annual personal income growth over the next several years is projected to exceed 4.8 percent, closely matching the national forecasts. Housing permits are projected to increase by 6.1% in 2006, and then drop to a more modest 3.3% level in 2007. Retail sales are projected to grow in excess of 5 percent annually for the next several years.

Although the economic outlook for the Puget Sound region is very positive, we remain conservative in our revenue forecasting. Overall, the City's operating revenues are projected to decrease by 2% when comparing the 2007 proposed budget to the 2006 budget. When comparing the 2007 proposed budget to the 2006 projected operating revenue collections, the 2007 operating revenues grow by 2.9%, \$805,000. The most significant changes are occurring in the City's gambling tax, utility tax, utility franchise, and utility contract payments.

Property taxes represent 23% of the City's operating revenue. The City's property tax collections are projected to increase by 1.9% over 2006 collections to a total of \$7 million for 2007. This

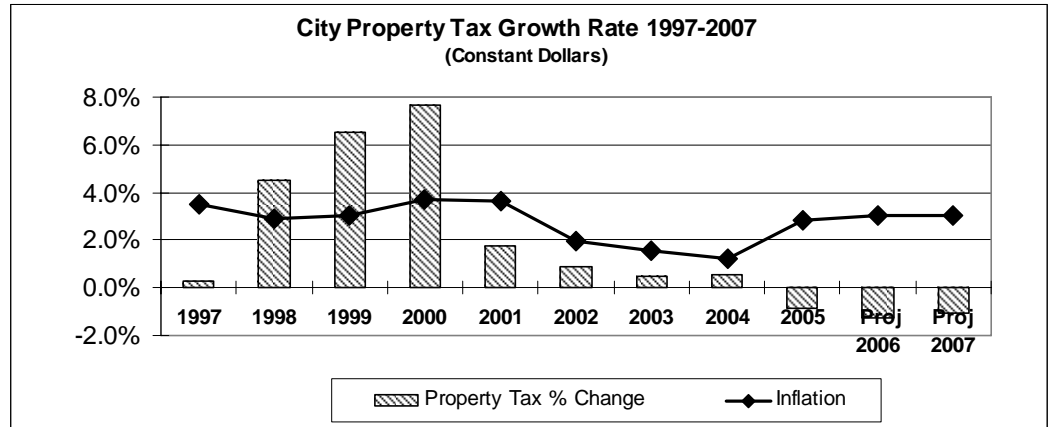

amount includes a 1% property tax levy increase, with an additional 0.9% of property tax revenue generated from new construction valued at approximately \$39 million. The 1% levy increase is the annual limit allowed by I-747, approved by Washington State voters in 2002. Although the 2007 budget provides for increased property tax revenues on a real basis, when adjusted for inflation and presented on a constant dollar basis, the City has had property tax revenue growth below inflation since 2001, and since 2005 the increases will not provide positive buying power.

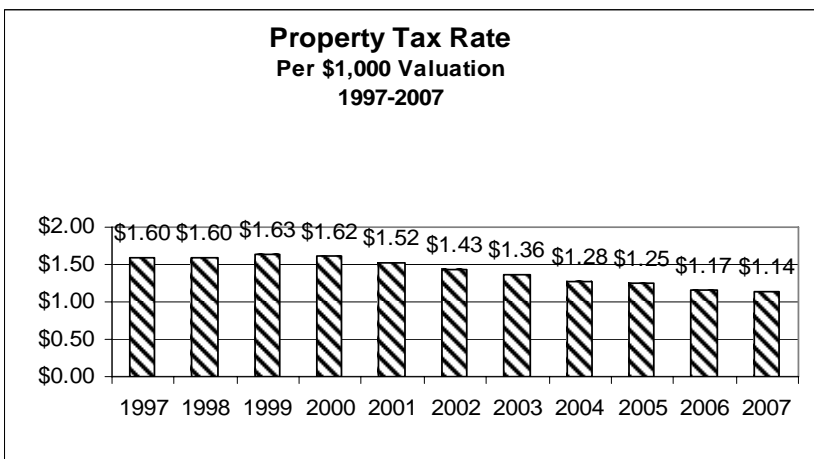

As a result of assessed valuation increases outpacing the increase in property tax levy over the last several years, the City's property tax rate has fallen every year since 2000. The estimated property tax levy rate for 2007 is \$1.14 per \$1,000 assessed valuation, a reduction from the 2006 rate of \$1.17. Statutorily, the City could levy up to a maximum property tax rate of \$1.60 per

\$1,000 assessed valuation. The average valued price home rose from \$289,000 in 2005 to \$314,000 in 2006. This is a 8.6% increase in average valuation. Assuming an overall 4% increase in valuation for 2007, the average valued home would increase to \$325,560 for

2007. The owner of an average valued home in 2007 could expect the City portion of their property tax to increase by approximately \$5, or 1.3%, in 2007. This property tax levy rate information is for the City's general levy. In May 2006 the Shoreline voters authorized the issuance of \$18.795 million in general obligation bonds. Property owners will be assessed a separate levy rate to begin the repayment of these bonds in 2007.

General sales tax, the second largest revenue source for City operations, totals \$6.25 million for 2007. Between 2001 and 2005 the City's annual sales tax growth has averaged 3.5% on a real dollar basis. The City continues to be conservative in its sales tax projections. The projected 2007 sales tax collections are estimated to increase by 8% as compared to the 2006 budget and 2.7% compared to projected 2006 collections.

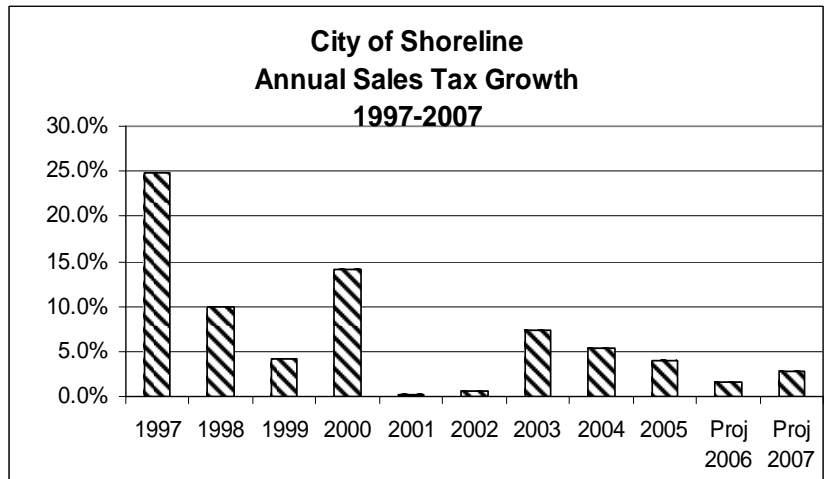

Shoreline's tax base consists largely of basic consumer goods, and therefore our sales tax collections have been fairly consistent over the last few years. Automobiles are the most significant luxury item in the Shoreline sales tax base, and these sales will need to be monitored throughout 2006. In 2005 sales tax from service industries decreased by 5%, construction related sales tax grew by 25%, while retail based sales tax grew by 6%.

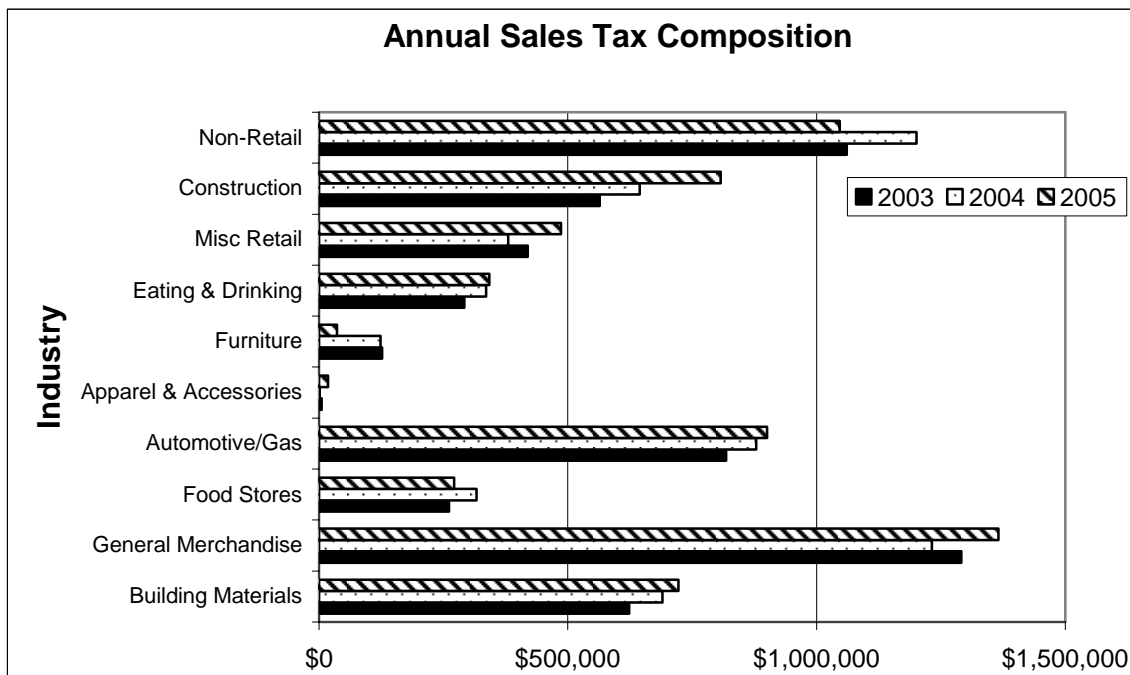

Utility taxes, franchise fees, and contract payments from utility providers are the third largest source of revenue for the City's operating budget. These revenues are projected to increase by approximately 5% when compared to projected 2006 collections.

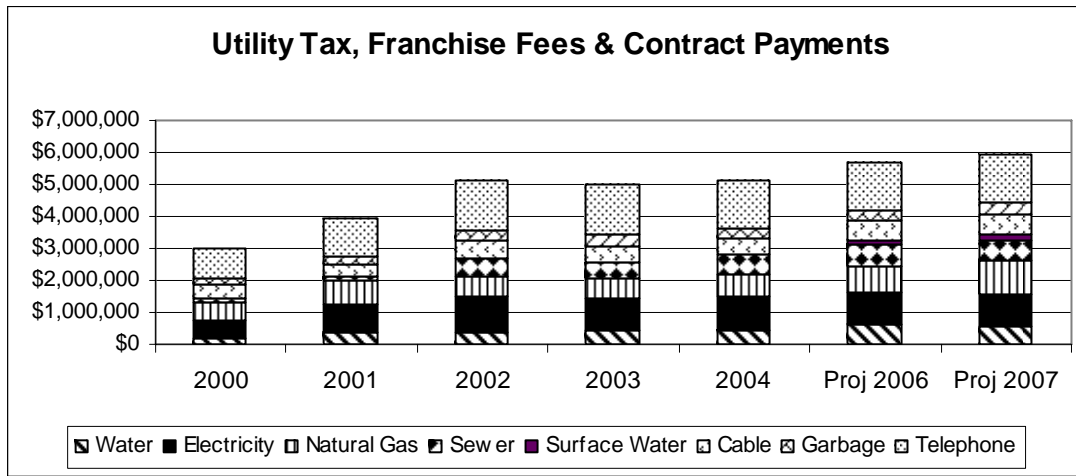

The most significant increase is projected to be from natural gas utilities. Natural gas collections are projected to increase 23% between 2006 and 2007.

The primary reason for this change is that Puget Sound Energy received approval for a 9% pass-through rate increase to be effective October 1, 2006, and other rate increases were approved in late 2005. The increases from telephone and cable are primarily related to usage increases. At this time electric rates charged by Seattle City Light (SCL) are projected to increase slightly for residential consumers, but decrease for commercial consumers. As a result we are projecting flat revenues from the contract payment made by SCL between 2006 and 2007. Other franchise fees and utility tax sources will remain relatively flat.

Reserves

The City saves a portion of its operating revenues as fund balance or "reserves". These funds are used to continue providing services when the economy weakens, to cover one-time expenditure needs and to meet unforeseen emergencies. To demonstrate prudent financial management, the City Council adopted a policy of maintaining

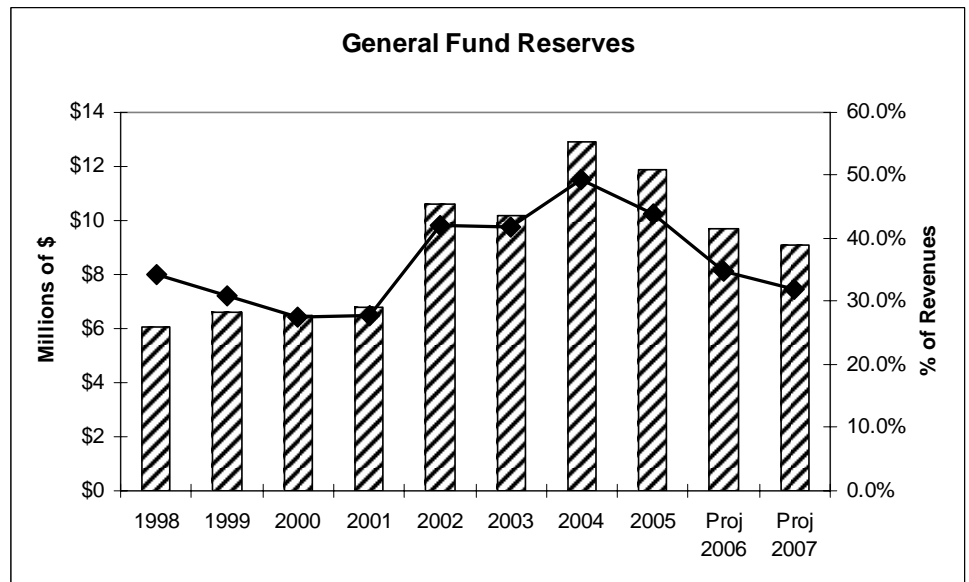

general reserves (General Fund and General Reserve Fund) at 10% of operating revenues. At the end of 2007, the City's general reserves are projected to total \$9.1 million or 32% of projected General Fund operating revenues.

The City’s general reserves will be in excess of the required 10% policy levels, and will be at the level maintained prior to 2002.

Staffing

The 2007 budget provides funding for 146.5 regular full-time equivalent (FTE) positions. Of these, 1.25 FTEs represent new positions: a Parks Maintenance Worker, and an increase of 0.25 FTE for two Finance Technicians. The City’s 2007 ratio of employees per 1,000 population is 2.64. As the graph below depicts, a comparison of staffing to population still shows the City of Shoreline staffing levels significantly below comparable cities. These ratios have been adjusted to **exclude** fire, police, special programs and utility personnel from comparable cities.



One-Time Expenditures

The 2007 operating budget includes \$266,500 in one-time resource allocations. \$120,000 of one-time expenditures is included in the City Street Fund. Of this amount, \$90,000 is allocated for the purchase of a street sweeper (an additional \$60,000 is budgeted in the Surface Water Utility Fund) and \$30,000 for contract street sweeping as it is anticipated that it will take 3 to 4 months to receive the street sweeper. The City’s General Fund includes \$146,500 in one-time expenditures.

Capital Budget

The City Council adopted the 2007-2012 Capital Improvement Program (CIP) in July of this year. The total CIP budget for facilities, parks, and transportation 2007 is \$31 million. The total 2007-2012 CIP is \$158.9 million. The 2007 budget for facilities, parks, and transportation is approximately \$22.5 million, 42%, less than the 2006 capital budget. The

surface water capital expenditures for 2007 total \$3.9 million. The surface water capital improvements are budgeted within the Surface Water Utility fund.

The CIP covers projects over \$10,000 and includes buildings, land acquisition, park facilities, road and transportation projects, and drainage system improvements. Much of the capital improvement activity is funded through contributions from the General Fund, Real Estate Excise Tax (REET), federal grants, and Public Works Trust Fund loans.

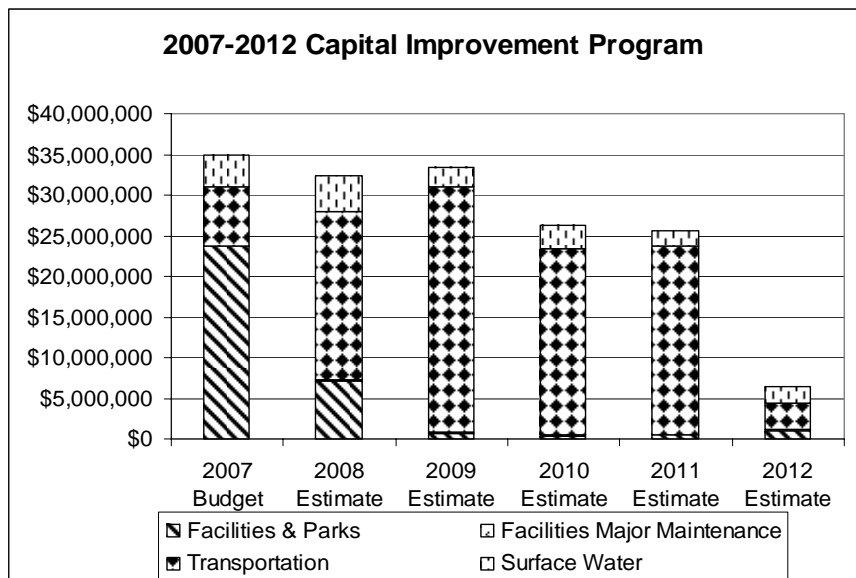

The previous chart provides a breakdown of the allocation of capital dollars for 2007 through 2012. The change in capital dollars can vary significantly from year to year based on available resources to complete projects and the impact of completed capital projects on the City’s operating budget.

Following are highlights from the 2007-2012 CIP projects that are either in progress or will be completed in 2007. Additional information on the CIP may be found in the Capital Improvement Program section of this budget document.

- ◆ The 2007-2012 CIP includes funding for the acquisition of property for a Civic Center and the construction of a City Hall. The current estimated project cost is \$28 million. This is a preliminary estimate, as the project is still in the early planning stages. It is anticipated that a property acquisition agreement will be completed in 2006, with design and construction occurring in 2007 through 2008.
- ◆ Parks Repair & Maintenance Program. The 2007-2012 CIP includes \$1.47 million for the systematic repair and replacement of major components of existing parks. These items may include benches, tables, fences, paths, and playground equipment. This funding is approximately 50% of the amount needed to fully fund all features of existing parks at their optimum life cycle replacement schedule.
- ◆ Initiate a Master Plan for the Twin Ponds Park. Total cost for developing the master plans is estimated at \$31,000. Funding for project implementation is not included in the 2007-2012 CIP.
- ◆ Funding towards the replacement of the Richmond Beach Saltwater Park Bridge is included in the CIP at \$869,000. This level of funding is not adequate to fully replace the bridge.

- ◆ The 2007-2012 CIP includes several projects that will be funded by the bond issue passed by voters in May 2006. These projects include the installation of artificial turf on some of the City's soccer fields, acquisition of open space properties, new pedestrian walkways and trail corridors, creation of an off-leash dog park, park improvements and improvements to tennis courts and baseball fields. Total improvements are approximately \$18.8 million.
- ◆ Annual preservation projects for roads, sidewalks, and traffic small works projects are funded at an annual average of \$1.3 million.
- ◆ The 2007-2012 CIP includes \$5.5 million for the construction of pedestrian walkways and sidewalks on priority City routes. During 2007-2008 funding the annual funding is from City resources. Beginning in 2009 alternative funding resources will be required to fully fund the projected CIP expenditures. The alternative funding may include Local Improvement Districts or other dedicated revenue streams.
- ◆ The most significant transportation project in the 2007-2012 CIP is the Aurora Corridor improvements between 165th and 205th.
 - Planning and design work start on the second phase of the Aurora Corridor project, 165th – 205th, in 2005 and will continue through 2007. The total estimated cost for this project is \$88 million, with \$77.5 million being funded through grants and other agency participation. The 2007 budget includes \$1.6 million for planning, design and right-of-way acquisition in 2007.
- ◆ The 2007 budget provides for the continuation of the Neighborhood Traffic Safety Program with approximately \$200,000 funded annually for capital improvements and \$50,000 funded within the operating budget for increased police traffic enforcement.
- ◆ In 2005 the City Council adopted the first surface water utility master plan. This plan included a recommended 20 year operating and capital improvement plan for the utility. The capital projects for the first 6 years of the plan are included in the 2007-2012 CIP. These projects focus on the desired level of service for flood protection, water quality, stream rehabilitation and habitat enhancement.

More detailed information about the projects within the City's 2007-2012 CIP can be obtained with a copy of the Adopted 2007-2012 CIP.

Other Budget Issues

One initiative that will be up for voter approval in the November state-wide election is I-933. Under I-933, state or local governments would have to compensate owners of private property when government regulations affect the value of their property. Government would be required to either "pay or waive" – compensate owners financially or waive the regulations.

A recently released study by the University of Washington found government most likely will be unable to do either. The three most common land-use laws – the Growth Management Act, the State Environmental Policy Act, and Shoreline Management Act – do not permit waivers. Meanwhile, the payments would likely be well beyond the budgets of cities or the state – totaling more than the state spends

In 2005 the City of Shoreline and several other cities that have a franchise agreement with Seattle City Light (SCL) were sued by a group of City of Seattle rate payers. The claim of the rate payers is that a contract payment made by SCL to the cities is not legal. Currently the City receives approximately \$1,000,000 a year from SCL as provided in the City's franchise agreement. It is anticipated that it will take time for this issue to be resolved through the court system.

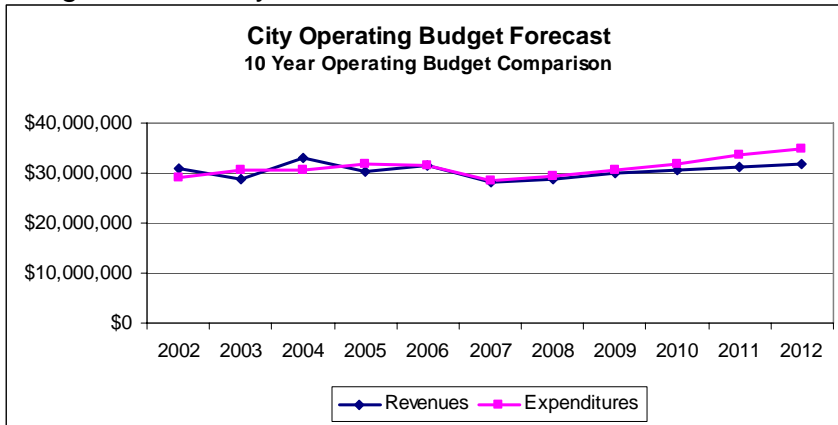

In 2006 the Shoreline voters approved a \$17.8 million Park and Recreation bond issue. The City is currently in the process of obtaining a bond rating and issuing the bonds. It is anticipated that the bonds will close in mid-December 2006. During the bond issuance process the City Council will adopt a

property tax levy rate for 2007 to start repayment of the bonds and will adopt a budget for the debt service requirements for 2007.

Shoreline Strategic Directions

Our organization has continued to focus on performance and results. This year the City Council updated the City's strategic plan. This included revising the City's vision, values, and strategic objectives. Included in the budget document is a working draft of the revised strategic plan. This plan identifies the desired community condition for each of the strategic objectives and the key strategies that the City will implement to obtain that condition. In order to measure the City's progress towards these goals, key performance measures have been identified. As annual results of these measures are recorded, the City will monitor trends to determine which strategies have been successful in moving us towards our desired community condition, and which strategies may need to be modified. I plan to use the Shoreline Strategic Directions tool to help communicate with the Shoreline community how we are doing as an organization in meeting the community's needs.

In addition to the performance measures included in the Strategic Directions document, the department budgets include service program summaries along with key performance measures and results of those measures for the last 3 years.

Our Financial Condition and Future Challenges

The City's current financial condition is excellent. Over the last five years, the City's revenue collections have exceeded expenditures as a result of conservative financial planning, efficient management, restraint from using budget savings as a way to fund on-going operations and modest budget increases. This has allowed the City Council to allocate monies towards significant capital projects such as the Civic Center in order to lower the amount of borrowing that will be necessary to complete the project.

Although the City reviews the long-term position of all funds, the primary focus is on the long-term financial position of the City's operating budget. The City is entering a time period in which annual expenditure growth is projected to outpace annual revenue growth, therefore resulting in future budget gaps. Based on the assumptions that the City uses in its long-term financial planning, this graph depicts the projected budget gaps between annual operating revenues and expenditures in the future.

The City's budget policies and state law dictate that the operating budget must be balanced on an annual basis with on-going revenue sources, unless a policy decision is made to use reserves in an emergency or as a one-time event. One of the advantages of doing long-term financial planning is that we can anticipate the need to either reduce expenditures, increase revenues, or do both. It also allows us to anticipate the need for future policy changes.

In light of the long-term forecasts, our focus over the last few years has been on cost containment, expenditure reductions and improving service efficiencies and I believe we have been very successful in this effort. Some of our successes include:

- In 2003 an employee group developed an alternative health benefit policy. As a result of this policy change, the City's health benefit costs in 2006 were \$313,000 less than would have been budgeted under the previous policy.
- We have initiated agreements with Yakima County and Issaquah to house prisoners at a lower rate than is charged by King County.
- We have changed the way we pay for Police Department canine services by purchasing this on a call-out basis instead of having a dedicated unit. This has resulted in annual savings of \$100,000.
- Departments absorbed \$167,000 in baseline budget reductions in 2005 and an additional \$169,000 in baseline reductions for 2007.

Based on our long-range projections, I believe the City will either have to implement new revenue sources or will need to reduce direct services in the future in order to balance the annual budget. The following table shows the anticipated budget gaps for 2008 through 2012 to maintain current service levels:

Expenditure Assumption	Operating Fund Projections					
	2007 100%			Others	99%	
	Base Projections					
	2007	2008	2009	2010	2011	2012
Annual Revenues	28,147,270	28,846,091	29,902,749	30,484,188	31,082,056	31,732,384
Annual Expenditures	28,413,771	29,261,795	30,706,207	31,917,785	33,487,243	34,826,839
Annual (Budget Gap)/Surplus	(266,501)	(415,704)	(803,458)	(1,433,597)	(2,405,187)	(3,094,455)

*2007 budget gap represents one-time expenditures which are being funded by reserves.

The City has several revenue options that could be implemented in the future. These include increasing the utility tax on cable from the current 1% up to 6%, increasing the utility tax on surface water fees beyond the current 6%, implementing the electricity contract payment on the distribution portion of the Seattle City Light rates, implementing a

revenue generating business license program, implementation of a business & occupation tax, increasing the gambling tax rate, or asking the voters to approve a property tax levy lid lift. Although all these options are available, I would recommend that we consider increasing the cable utility tax, implementing the electricity contract payment on the distribution portion of the electric fees, and a property tax levy lid lift in the future.

As the projections above portray, the City will need to either implement alternative revenues in 2008 or make program reductions in order to balance the 2008 budget. I would recommend that the Council consider a strategic plan to gradually implement the cable utility tax increase and the electricity contract increase starting in 2008. If the cable utility tax was increased to the full 6%, the City could anticipate collecting an additional \$500,000 in annual revenue, and if the full 6% contract payment were implemented on the distribution portion of the electric rates the City could collect up to \$850,000 in additional annual revenue. These rate changes can be phased in over time. One example would be the following:

	2008	2009	2010	2011	2012
Projected Annual (Budget Gap)/Surplus	(415,704)	(803,458)	(1,433,597)	(2,405,187)	(3,094,455)
Cable Utility Tax Increase (1%-2008, 2%-2009, 2%-2010)	100,000	300,000	500,000	500,000	500,000
Electric Contract Payment Increase (2%-2008, 2%-2009, 2%-2010)	283,333	566,667	850,000	850,000	850,000
Net Budget Gap	<u>(32,371)</u>	<u>63,209</u>	<u>(83,597)</u>	<u>(1,055,187)</u>	<u>(1,744,455)</u>

As stated earlier this scenario only assumes that the City maintain current service levels. As can be seen from this scenario these revenue sources would provide the means to be able to maintain the existing level of service through 2010, but will not be sufficient to maintain service levels beyond that time frame.

Council has discussed a desire to enhance service levels specifically in the areas of human service funding and public safety. In addition to those needs I believe that we may need additional funding in our park and right-of-way maintenance areas in the future. The Council may want to consider revenue from a levy lid-lift to fund enhanced levels of service. The City may levy a property tax rate up to \$1.60 per \$1,000 assessed valuation. The current projected 2007 levy rate is \$1.14. This leaves an additional \$0.46 that could be levied. Each \$0.05 of additional levy generates approximately \$310,000 in annual revenue.

I realize that revenue enhancement options are not popular, but at the same time our community desires a responsive and responsible City government. I believe we have served the community well during our first decade of incorporation as we have used resources efficiently to improve the services our community received in public safety, park and street maintenance, communications and human services. Also we have provided many capital and infrastructure improvements within current revenue sources.

I believe that 2007 will be a critical year for us to make decisions about our long-term financial strategy and therefore I anticipate bringing additional information to the City Council in early 2007 so that these policy decisions may be made as we plan for 2008 and beyond.

I am very confident, given our past conservative financial planning and spending policies that we will develop a long-term financial strategic plan that will support our City vision.

Conclusion

This budget is an effort to comprehensively address the City's service and capital investment needs for 2007. It is a budget that continues to provide current service levels, but it does not satisfy all the demands placed on the City. The 2007 proposed budget addresses the top priorities identified by the Council and the Shoreline community. It does this through conservative revenue estimates and modest expenditure growth.

In presenting the budget to the Council, I would like to acknowledge and express appreciation to the City Leadership Team and their staff for their willingness to submit realistic budget requests and develop alternatives to meet the Council priorities. I would also like to thank the Finance Department for its assistance in preparing this budget. Finally, I would like to thank you, the Council, for the policy direction you have provided for service delivery to our community.

Respectfully submitted,

Robert Olander
City Manager



This Page Has Been Intentionally Left Blank

2007-2008 CITY COUNCIL GOALS

VISION

A community of families, safe neighborhoods, diverse cultures, active partnerships, quality businesses, natural resources, and responsive government



VALUES

- Strong neighborhoods, citizen partnerships, and active volunteers
- Social, cultural and economic diversity
- Human service connections and networks
- Open, efficient, participatory government
- Community and regional leadership and collaboration
- Sustainability and stewardship of the environment and natural resources
- Quality educational, recreational, and cultural opportunities for all ages

STRATEGIC OBJECTIVES

- Safe and attractive neighborhoods and business districts
- Quality services, facilities, and infrastructure
- Safe, healthy and sustainable environment
- Government excellence
- Economic vitality and financial stability
- Human services
- Effective citizen communication and engagement

- Goal No. 1 Complete the projects approved in the 2006 Parks Bond
- Goal No. 2 Implement the Economic Development Strategic Plan
- Goal No. 3 Implement an affordable civic center/city hall project
- Goal No. 4 Complete the Aurora improvements from 165th to 205th Streets including, but not limited to, sidewalks, drainage and transit
- Goal No. 5 Develop a comprehensive housing strategy
- Goal No. 6 Create an "environmentally sustainable community"
- Goal No. 7 Provide safe and affordable transportation options to support land use plans including walking, bicycling, transit and vehicular options
- Goal No. 8 Develop a Fircrest master plan in partnership with the State
- Goal No. 9 Increase emergency preparedness training and education
- Goal No. 10 Increase opportunities for all residents, including our youth, to get more involved in neighborhood safety and improvement programs

STRATEGIC OBJECTIVES	DESIRED COMMUNITY CONDITION	STRATEGIES	PERFORMANCE MEASURES	2004 ACTUAL	2005 ACTUAL	2006 ACTUAL	DATA TREND
SAFE AND ATTRACTIVE NEIGHBORHOODS AND BUSINESS DISTRICTS 	<ul style="list-style-type: none"> • Residents feel safe in their neighborhoods • Residents are safe from crimes against persons and property • Residents and visitors are safe to travel on streets and walkways • The community is prepared for natural and man-made disasters • Neighborhoods are free from blight and deterioration 	<ul style="list-style-type: none"> • Increase active block watch programs • Implement auto theft action plan • Implement traffic enforcement enhancement plan • Complete neighborhood traffic action plans • Complete 2007-08 priority sidewalk projects • Implement public education/outreach campaign • Install emergency generator at Spartan Recreation Center Shelter • Provide federally mandated training for staff • Implement priority elements of the Hazard Mitigation Plan • Conduct table top and field earthquake preparedness drill • Improve code enforcement program • Review IBC interior property maintenance codes • Implement an "adopt-a-road, -park and -trail" programs 	<ul style="list-style-type: none"> • % of residents who feel safe in their neighborhood during the day • Part I crimes per 1,000 population • Traffic accidents per 1,000 population • Miles of separated pedestrian pathways • % of households that believe they are prepared for a 7-day emergency • % of residents who rate their neighborhood condition as excellent/good • % of residents who rate the overall quality of life as excellent/good 	92%	92%	NA	↔
			<ul style="list-style-type: none"> • % of residents who feel safe in their neighborhood during the day • Part I crimes per 1,000 population • Traffic accidents per 1,000 population • Miles of separated pedestrian pathways • % of households that believe they are prepared for a 7-day emergency • % of residents who rate their neighborhood condition as excellent/good • % of residents who rate the overall quality of life as excellent/good 	46	47	NA	↑
QUALITY SERVICES, FACILITIES, AND INFRASTRUCTURE 	<ul style="list-style-type: none"> • Residents have safe and affordable transportation options • The street system is well maintained • Residents and businesses are safe from flooding • City services are delivered effectively and efficiently • Residents are provided with timely and responsive public services • Quality parks, open space trails and recreational activities are available to all residents • Aurora Avenue provides improved safety and mobility for vehicles and pedestrians, Bus Rapid Transit, good business access, and improved economic vitality 	<ul style="list-style-type: none"> • Complete Interurban Trail and bridges • Work with transit providers to expand transit in Shoreline • Implement Transportation Master Plan • Complete 2007-08 pavement projects • Complete civic center/city hall • Update performance measures and targets • Develop "community report card" • Complete 2006 parks bond projects: acquire properties; complete master plans; construct improvements • Complete Aurora Phase I • Complete environmental analysis, preliminary design and public process for Aurora Phase II 	<ul style="list-style-type: none"> • Transit ridership in Shoreline • Miles of bike lanes, routes and trails • Overall pavement condition rating (0-100) • % of residents very/somewhat satisfied with maintenance of streets • Number of flood incidents (structures damaged) • % of residents who rate the value of services received for City taxes as excellent/good • Operating expenses per capita (constant \$) • Benchmark comparisons with other cities • % of households rating condition of parks as excellent/good • % of households located within 1/2 mile of neighborhood park • % of users rating recreation programs as excellent/good 	NA	NA	NA	↔
			<ul style="list-style-type: none"> • Transit ridership in Shoreline • Miles of bike lanes, routes and trails • Overall pavement condition rating (0-100) • % of residents very/somewhat satisfied with maintenance of streets • Number of flood incidents (structures damaged) • % of residents who rate the value of services received for City taxes as excellent/good • Operating expenses per capita (constant \$) • Benchmark comparisons with other cities • % of households rating condition of parks as excellent/good • % of households located within 1/2 mile of neighborhood park • % of users rating recreation programs as excellent/good 	81	81	NA	↔

STRATEGIC OBJECTIVES	DESIRED COMMUNITY CONDITION	STRATEGIES	PERFORMANCE MEASURES	2004 ACTUAL	2005 ACTUAL	2006 ACTUAL	DATA TREND
SAFE, HEALTHY AND SUSTAINABLE ENVIRONMENT 	<ul style="list-style-type: none"> Surface water quality meets/exceeds state and federal standards Solid waste is diverted from landfills The urban forest is preserved and enhanced Higher density residential options are available within walking distance of neighborhood commercial centers Shoreline has an active "Green Street" Program Shoreline is a leader in energy efficiency, alternative renewable energy, and global warming pollutant reduction 	<ul style="list-style-type: none"> Update Storm Water Management Standards including low impact development Create demonstration SWM standards for Aurora Phase II Conduct two recycling events Complete and implement Natural Resources Management Plan Complete Town Center Plan Initiate Ballinger Special Study Area Plan Complete Fircrest master plan Implement a "Green Street" demonstration project Implement the Mayor's Climate Protection Agreement 	<ul style="list-style-type: none"> % of tree canopy coverage in city # of street trees # of housing units within 1/2 mile of commercial amenities % of surface water quality tests meeting adopted targets % of solid waste stream recycled Average City fleet fuel efficiency 	NA	NA	NA	↔
GOVERNMENTAL EXCELLENCE 	<ul style="list-style-type: none"> Shoreline leaders are effectively engaged in regional decisions affecting Shoreline Up-to-date long range land use, transportation, capital, SWM, and parks plans Professional and committed workforce 	<ul style="list-style-type: none"> Councilmembers actively participate in SCA, PSRC, WIRA 8 Complete critical areas tree update Implement updated employee recognition program Continue to expand employee communication training Implement "mid management" training program 	<ul style="list-style-type: none"> # of regional and national committees with Council-staff representation % of CIP funded by state and federal grants % of residents rating quality of customer service as excellent/good % of employees who believe customer service is a high priority % of employees who would recommend working for the City to a friend % of employees rating support services as excellent/good 	18	17	17	↔
ECONOMIC VITALITY AND FINANCIAL STABILITY 	<ul style="list-style-type: none"> Public services and amenities (transportation, transit, water, sewer, power, etc.) are available to support economic and residential growth Effective programs and resources are available to promote diversification, retention, and growth of existing small businesses There are thriving neighborhood commercial areas available to residents throughout the community Aurora Square redevelops as a major regional destination shopping area The City has sufficient fiscal capacity to fund and maintain priority public services, facilities, and infrastructure 	<ul style="list-style-type: none"> Negotiate acquisition of SPU water system Implement Small Business Assistance Program Initiate Aurora construction mitigation promotion Facilitate planning for "wedges" properties Complete Ridgcrest Neighborhood Commercial Area Plan Promote redevelopment of Aurora Square Update and implement the long-range financial plan 	<ul style="list-style-type: none"> Retail sales tax per capita % of commercial assessed value of total City assessed value Bond rating Assessed value per capita General debt per capita 	\$109	\$111	NA	↔
HUMAN SERVICES 	<ul style="list-style-type: none"> Safe and affordable housing is available for residents The community provides support for responsible social development of youth Residents have adequate levels of food, shelter, clothing, and medical care The community provides support for the physical and social needs of senior citizens 	<ul style="list-style-type: none"> Complete Comprehensive Housing Strategy Update youth strategies Review and update "Human Services Outcomes" Complete senior housing strategy 	<ul style="list-style-type: none"> Amount of subsidized housing available (Section 8 Vouchers, King County Housing Authority Managed Units) # of major home repairs completed # of minor home repairs completed # of residents served through human service contracts (some residents are duplicated) 	895	895	895	↔
EFFECTIVE CITIZEN COMMUNICATION AND ENGAGEMENT 	<ul style="list-style-type: none"> Residents are well informed of current community issues and events City programs and services are aligned with community values and priorities Active and engaged neighborhood associations 	<ul style="list-style-type: none"> Implement web casting of Council meetings Complete vision and goals update Update performance measures Conduct community survey Increase participation in neighborhood Mini-Grant Program Implement targeted youth safety campaign 	<ul style="list-style-type: none"> % of residents satisfied with the City's efforts to keep residents informed % of residents satisfied with the level of public involvement in local decision-making % of residents who feel the City is moving in the right direction # of citizen volunteer hours 	66%	66%	NA	↔

Please Note:

- NA is defined as "not available"; these are generally for newly identified indicators and the data is in the process of being collected.
- Not all of the City's performance measures collected by departments and/or program areas are included here.
- The citizen satisfaction survey (2002, 2004), the employee satisfaction survey (2003, 2005), and internal customer service survey (2004, 2006) are conducted every other year and the previous year's results are carried over.



EXECUTIVE SUMMARY

The City Budget

Where the money will come from

2007 City Resources By Category \$68,206,170

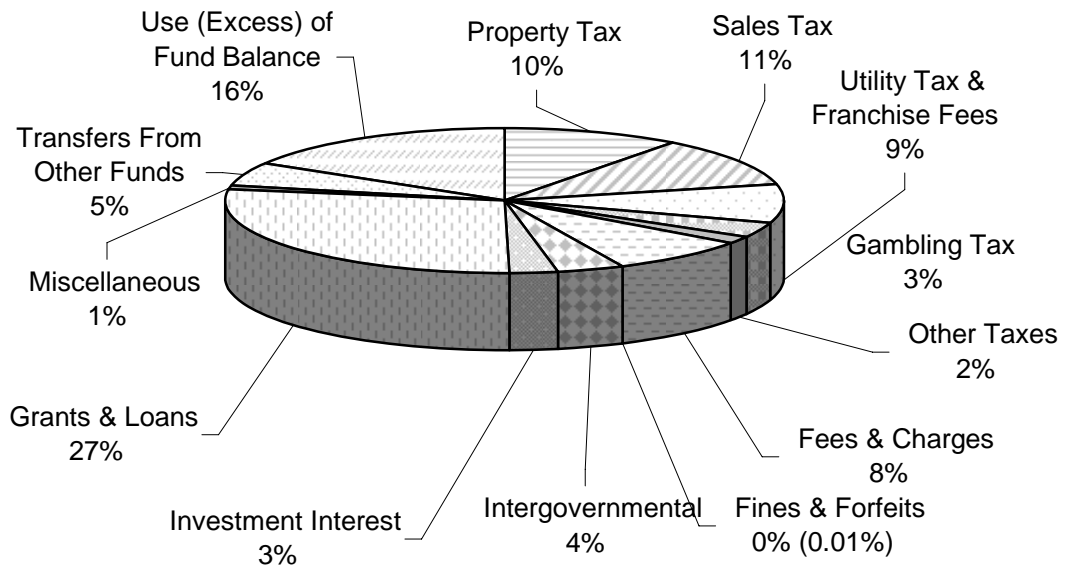

How will the money be spent

2007 City Expenditures By Category \$68,206,170

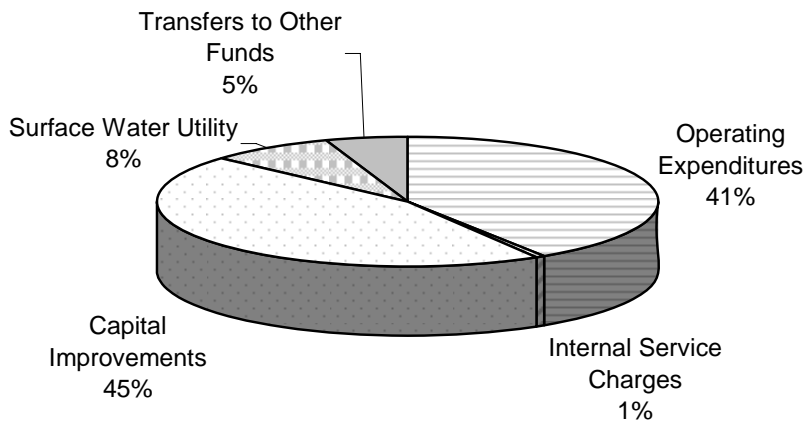

City Budget Summary

Listed below are the resources and expenditures for all City funds. City Resources shows all revenue by category. City Expenditures lists the operating uses by department and functional area. The Operating Budget represents expenses necessary to run the City government on a daily basis. Contingencies represent funding that set aside for potential or unforeseen expenditures that may occur. Capital Improvements are the purchase land, construction of a building, major street construction or reconstruction, or drainage system improvements. Transfers to Other Funds represent transfers of appropriations from one City fund to another City fund for services or the transfer of funds for capital purposes from the operating funds to the capital funds. Revenue and expenditures are recorded in both funds. Ending Fund Balance represents the reserves that are available to the City at the end of any given year. These reserves represent both reserves for unanticipated events and reserves designated for future capital purposes.

	2004 Actual	2005 Actual	2006 Current Budget	2006 Projected	2007 Proposed Budget	\$ Change From 2006 Budget	% Change from 2006 Budget
Resources:							
Beginning Fund Balance	41,160,152	44,810,019	35,972,706	45,372,334	39,047,488	3,074,782	8.5%
Revenues:							
Property Tax	6,714,399	6,822,871	6,935,415	6,935,415	7,066,510	131,095	1.9%
Sales Tax	6,798,535	7,108,440	6,886,187	7,237,089	7,474,500	588,313	8.5%
Utility Tax & Franchise Fees	5,132,665	6,249,469	5,386,000	5,692,000	5,965,595	579,595	10.8%
Gambling Tax	3,321,060	3,003,004	2,930,500	2,053,800	2,134,500	(796,000)	-27.2%
Other Taxes	2,023,780	2,678,132	1,428,848	1,953,500	1,225,672	(203,176)	-14.2%
Fees & Charges	4,380,437	4,990,255	5,166,603	5,229,327	5,573,190	406,587	7.9%
Fines & Forfeits	127,917	77,831	11,000	31,261	10,000	(1,000)	-9.1%
Intergovernmental	1,994,377	7,149,388	6,051,035	5,809,626	2,531,582	(3,519,453)	-58.2%
Investment Interest	851,635	1,208,119	1,233,738	2,260,274	1,975,514	741,776	60.1%
Grants & Loans	6,139,190	8,341,852	31,889,393	40,889,943	18,833,541	(13,055,852)	-40.9%
Miscellaneous	349,077	438,077	867,671	788,771	548,561	(319,110)	-36.8%
Sub-Total Revenues	37,833,072	48,067,438	68,786,390	78,881,006	53,339,165	(15,447,225)	-22.5%
Transfers From Other Funds	7,239,729	8,996,559	8,641,650	6,547,222	3,600,570	(5,041,080)	-58.3%
Total Revenues	45,072,801	57,063,997	77,428,040	85,428,228	56,939,735	(20,488,305)	-26.5%
Total Resources	86,232,953	101,874,016	113,400,746	130,800,562	95,987,223	(17,413,523)	-15.4%
Uses:							
Operating Expenditures:							
City Council	163,784	165,668	167,738	173,123	174,494	6,756	4.0%
City Manager	620,438	895,736	864,358	879,464	815,352	(49,006)	-5.7%
City Clerk	320,170	351,677	387,159	371,393	403,027	15,868	4.1%
Community & Govt. Relations	472,999	493,268	580,158	560,082	578,700	(1,458)	-0.3%
Human Services	453,325	564,457	587,209	576,397	592,010	4,801	0.8%
City Attorney	414,970	445,997	523,040	553,040	550,782	27,742	5.3%
Finance	3,000,927	3,083,800	3,254,050	3,453,113	3,289,883	35,833	1.1%
Human Resources	340,294	344,954	369,222	369,222	391,553	22,331	6.0%
Customer Response Team	380,971	365,609	410,283	407,783	440,585	30,302	7.4%
Police	7,299,588	7,459,839	8,109,873	7,991,308	8,555,045	445,172	5.5%
Criminal Justice	924,993	1,156,910	973,104	1,348,400	1,379,426	406,322	41.8%
Parks & Recreation	2,794,532	3,352,058	3,932,369	3,819,718	3,879,687	(52,682)	-1.3%
Planning & Development Services	1,994,862	2,091,168	2,526,641	2,380,640	2,856,866	330,225	13.1%
Economic Development	77,066	155,259	294,521	296,078	245,596	(48,925)	-16.6%
Public Works	4,416,937	2,973,148	3,326,797	3,362,692	3,118,428	(208,369)	-6.3%
Contingencies	-	-	758,572	-	598,465	(160,107)	-21.1%
Operating Expenditures	23,675,856	23,899,548	27,065,094	26,542,453	27,869,899	804,805	3.0%
Internal Service Charges	237,817	249,630	277,176	278,914	309,284	32,108	11.6%
Capital Improvements	10,269,534	19,289,020	53,513,476	56,409,227	30,943,898	(22,569,578)	-42.2%
Surface Water Utility	-	4,066,936	3,395,403	2,966,603	5,482,519	2,087,116	61.5%
Transfers to Other Funds	7,239,730	8,996,558	8,607,758	5,555,878	3,600,570	(5,007,188)	-58.2%
Total Expenditures	41,422,937	56,501,692	92,858,907	91,753,075	68,206,170	(24,652,737)	-26.5%
Ending Fund Balance	44,810,016	45,372,324	20,541,839	39,047,487	27,781,053	7,239,214	35.2%
Use (Excess) of Fund Balance	(3,649,864)	(562,305)	15,430,867	6,324,847	11,266,435	(4,164,432)	-27.0%

*The difference between transfers in and transfers out represents the transfer of monies from the City's capital funds to the Public Arts Fund. The expenditure of these funds is incorporated within the project costs as opposed to being shown as an operating transfer.

City of Shoreline 2007 All Funds Resources/Expenditures Summary

Fund	Beginning Fund Balance	2007 Revenue	2007 Transfers-In	2007 Total Resources	2007 Expenditures	2007 Transfers-Out	Ending Fund Balance	Total 2007 Appropriation
General Fund	\$ 7,394,350	\$ 26,729,033	\$ 1,046,447	\$ 35,169,830	\$ 25,872,858	\$ 2,554,123	\$ 6,742,849	\$ 28,426,981
Street Fund	795,243	901,966	1,400,121	3,097,330	1,891,911	530,176	675,243	2,422,087
General Reserve Fund	2,282,647	58,546	-	2,341,193	-	-	2,341,193	-
Code Abatement Fund	68,128	82,500	-	150,628	100,000	-	50,628	100,000
Asset Seizure Fund	33,831	23,500	-	57,331	23,500	-	33,831	23,500
Public Art Fund	212,240	-	-	212,240	-	-	212,240	-
General Capital Fund	12,232,990	14,569,580	361,000	27,163,570	23,657,469	33,754	3,472,347	23,691,223
City Facility-Major Maint. Fund	177,152	7,972	70,000	255,124	110,000	-	145,124	110,000
Roads Capital Fund	7,885,027	5,270,503	613,002	13,768,532	7,177,754	55,680	6,535,098	7,233,434
Surface Water Utility Fund	6,363,913	5,339,508	-	11,703,422	5,522,120	426,837	5,754,464	5,948,957
Vehicle Operations Fund	59,637	139,988	-	199,625	139,988	-	59,637	139,988
Equipment Replacement Fund	1,470,072	215,569	100,000	1,785,641	100,000	-	1,685,641	100,000
Unemployment Fund	72,258	500	10,000	82,758	10,000	-	72,758	10,000
Total City Funds	\$ 39,047,488	\$ 53,339,165	\$ 3,600,570	\$ 95,987,224	\$ 64,605,600	\$ 3,600,570	\$ 27,781,053	\$ 68,206,170

2007 Appropriation By Fund \$68,206,170

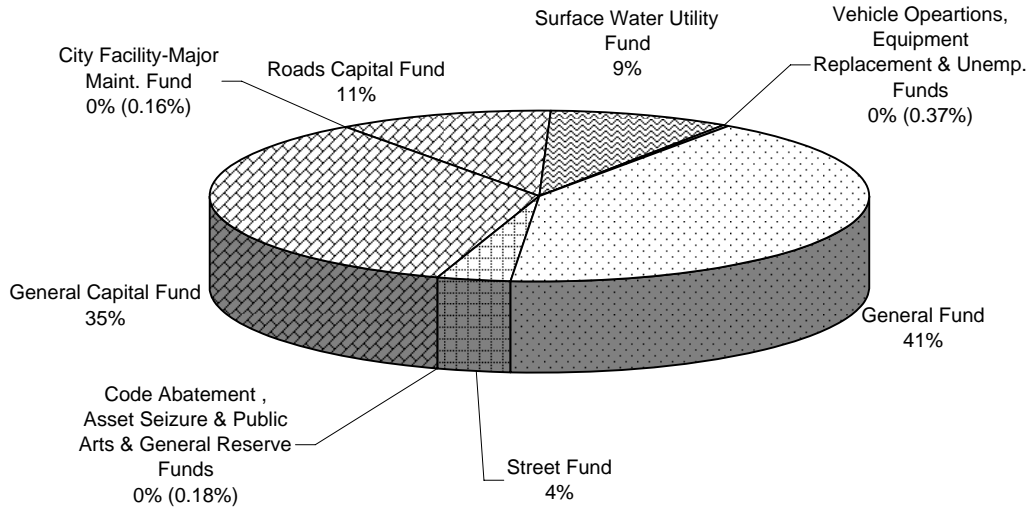

2007 Appropriation By Type \$68,206,170

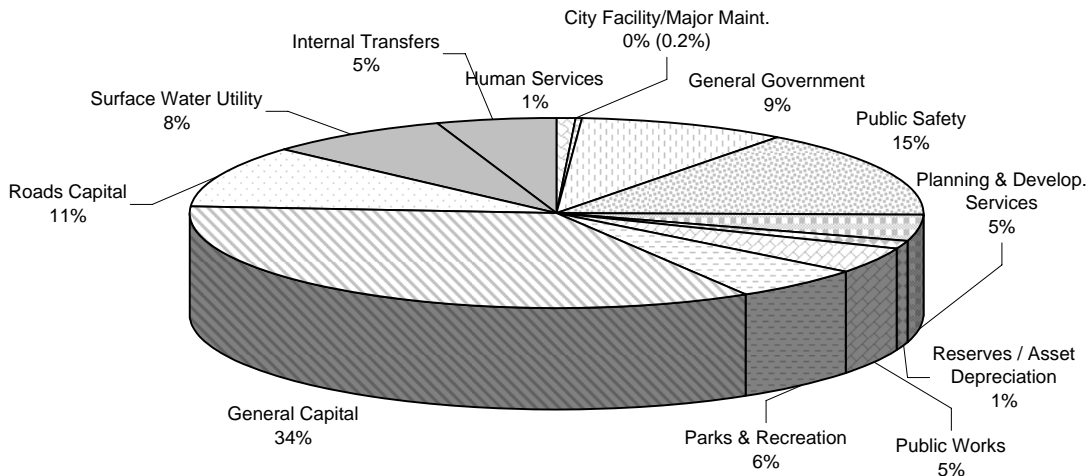

OPERATING BUDGET FORECAST SIX YEAR FORECAST

	2007 Forecast	2008 Forecast	2009 Forecast	2010 Forecast	2011 Forecast	2012 Forecast
Beginning Fund Balance	\$ 10,387,593	\$ 10,121,092	\$ 9,705,388	\$ 8,901,930	\$ 7,468,333	\$ 5,063,146
Revenues:						
Taxes:						
Property	7,066,510	7,181,085	7,295,541	7,409,913	7,524,236	7,638,543
Sales and Use	7,474,500	7,818,867	8,173,073	8,489,788	8,826,701	9,176,984
Gambling	2,134,500	2,273,090	2,264,765	2,256,856	2,249,343	2,242,205
Utility	3,215,000	3,302,117	3,381,902	3,460,422	3,541,329	3,622,819
Other	672	672	672	672	672	672
Franchise/Utility Contract Payments	2,750,595	2,816,574	2,883,740	2,949,693	3,017,683	3,086,121
Licenses and Permits	1,037,865	1,019,935	1,017,483	995,057	966,725	960,503
Intergovernmental	1,772,375	1,825,188	1,857,192	1,888,697	1,921,168	1,953,612
Charges for Services	1,593,750	1,530,914	1,550,369	1,554,731	1,555,483	1,571,854
Fines and Forfeitures	10,000	10,000	10,000	10,000	10,000	10,000
Interest Income	410,000	385,000	385,000	385,000	385,000	385,000
Miscellaneous Revenues	165,232	165,513	165,798	166,070	166,351	166,630
Total Revenue	27,630,999	28,328,955	28,985,534	29,566,899	30,164,691	30,814,943
Operating Expenditures						
Salaries & Benefits	10,719,469	11,178,587	11,752,507	12,274,435	12,830,776	13,409,010
Supplies	643,468	637,067	637,084	637,102	637,119	637,137
Services & Charges	5,485,003	5,424,864	6,072,031	6,216,347	6,656,793	6,817,312
Intergovernmental	9,943,818	10,235,990	10,742,105	11,273,272	11,831,212	12,417,049
Interfund	260,858	261,391	264,588	267,675	270,871	274,068
Debt Service	0	-	-	-	-	-
Other	93,465	94,458	97,284	100,141	103,139	106,226
Capital Outlay	114,000	7,425	7,425	7,425	7,425	7,425
Total Operating Expenditures	27,260,081	27,839,783	29,573,025	30,776,396	32,337,335	33,668,228
Revenue Over (Under) Expenditures	370,918	489,172	(587,491)	(1,209,496)	(2,172,644)	(2,853,285)
Other Financial Sources (Uses)						
Operating Transfers In	516,271	516,271	916,271	916,271	916,271	916,271
Transfers Out	1,153,690	1,421,147	1,132,239	1,140,371	1,148,814	1,157,441
Net Budget Surplus (Gap)	(266,501)	(415,704)	(803,458)	(1,433,597)	(2,405,187)	(3,094,455)
Ending Fund Balance	\$ 10,121,092	\$ 9,705,388	\$ 8,901,930	\$ 7,468,333	\$ 5,063,146	\$ 1,968,691

*2007 Gap Represents the use of fund balance for one-time expenditures

Assumptions

Inflation	3.20%	2.72%	2.69%	2.53%	2.56%	2.49%
Annual Sales & Use Tax Change	4.10%	4.65%	4.58%	3.90%	3.98%	3.98%
General Fees & Licenses Increase	2.40%	2.04%	2.02%	1.90%	1.92%	1.87%
Investment Interest Rate	5.00%	5.00%	5.00%	5.00%	5.00%	5.00%
Building Permit Change	0.50%	-3.70%	-1.00%	-4.70%	-6.10%	-1.90%
Revenue Collection	100.00%	100.00%	100.00%	100.00%	100.00%	100.00%
PERS Employer Contribution Rate	5.74%	6.79%	7.55%	7.48%	7.48%	7.48%
Health Benefit Escalator	7.50%	7.50%	7.50%	7.50%	7.50%	7.50%
Regular Salary Escalator	4.88%	4.45%	4.42%	4.28%	4.30%	4.24%
Police Contract Escalator	5.00%	5.00%	5.00%	5.00%	5.00%	5.00%
Expenditure Percentage	100.00%	99.00%	99.00%	99.00%	99.00%	99.00%
New Maintenance Costs for Completed Capital Projects	\$ 175,706	\$ 5,000	\$ -	\$ -	\$ 292,712	\$ -

2007 City Revenue Sources

Introduction

The City of Shoreline receives revenues from local property, sales, utility, and gambling taxes, a variety of population based state-shared revenues, user fees for development services and parks programs as well as grants, fines, and other miscellaneous revenues. In 2007, the total revenue for all of the City's funds is \$68,480,784. This includes the budgeted use of beginning fund balances and transfers between funds.

General Fund Revenue Sources

In 2007, the General Fund resource base is \$28,426,980. This is made up of the budgeted use of fund balance (\$651,500, 2.3%), operating revenues (\$26,729,033, 94%), and transfers-in (\$1,046,447, 3.7%) from other funds for their share of the General Fund overhead.

General Fund Revenue Sources

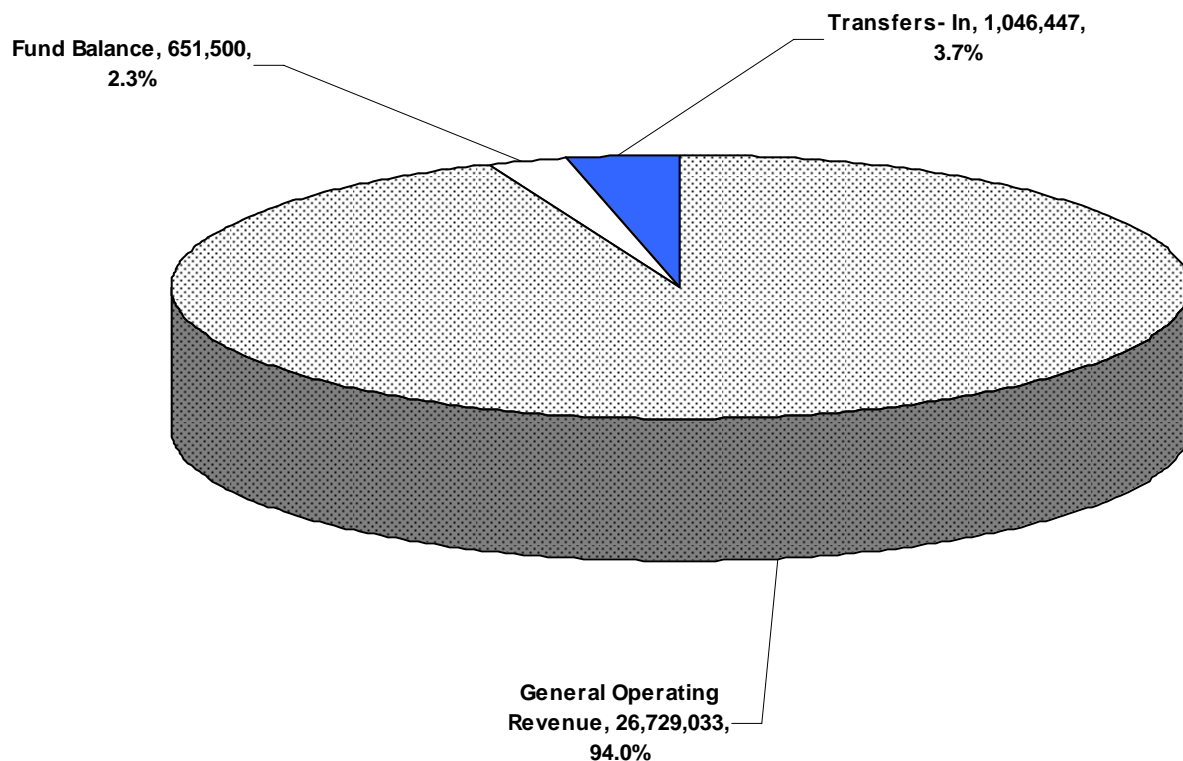

General Fund Operating Revenues

General Fund Operating Revenue Breakdown

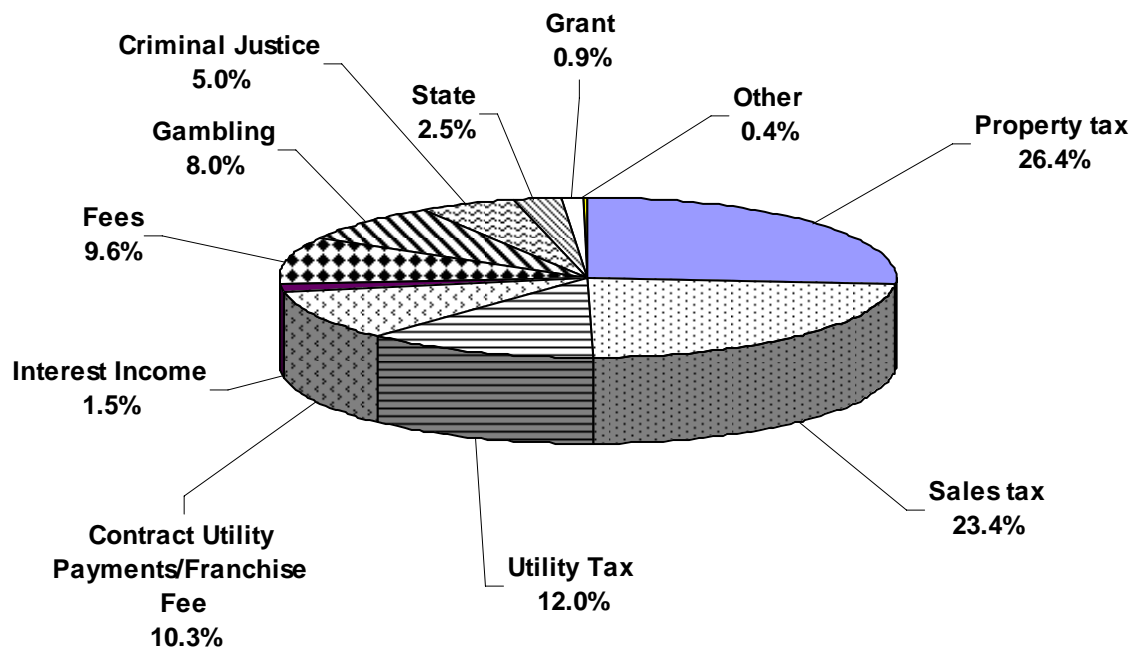

Property Tax

Property tax revenue for 2007 is budgeted at \$7,066,510 and represents 26.4% of the General Fund operating revenues. The 2006 budgeted property tax is \$6,935,415 and represented 26.6% of the adopted General Fund operating revenues. 2007 revenue is a \$131,095 or 1.9% increase over 2006, this slight increase is a result of new construction and a one-percent recommended levy increase. The one-percent levy increase is the maximum annual growth allowed since the passage of Initiative 747. I-747 requires voter approval for any property tax levy increases in excess of one-percent.

The current 2006 City of Shoreline property tax levy rate is \$1.17 per \$1,000 of assessed property value. This does not include levies for the school district, library district, fire district, County, Port, State or other agencies. When all the taxing jurisdictions levy rates are included the total levy rate is \$11.78 per \$1,000. A homeowner of an average valued residence \$314,000 is currently paying a total of \$3,698 per year in property taxes. The City receives 9.93% of the property tax levied, which would equate to \$367.38.

The projected tax levy rate for 2007 is \$1.14 per \$1,000 valuation, a reduction from the 2006 rate of nearly 2.87%. The 2006 levy rate was 5.47% less than the 2005 rate. The primary reason for the decrease in rate is that assessed value of property in the City has increased at a greater rate than the property tax levy has grown.

The assessed valuation for 2007 is estimated to be 4.65% more than the current level, totaling \$6,243,181,434. The 2007 Budget includes the increases from the 1.0% levy increase, new construction and previous years' refunds.

The following charts provide information regarding the City's property tax levy rate and the allocation of the total levy rate for all taxing districts within Shoreline.

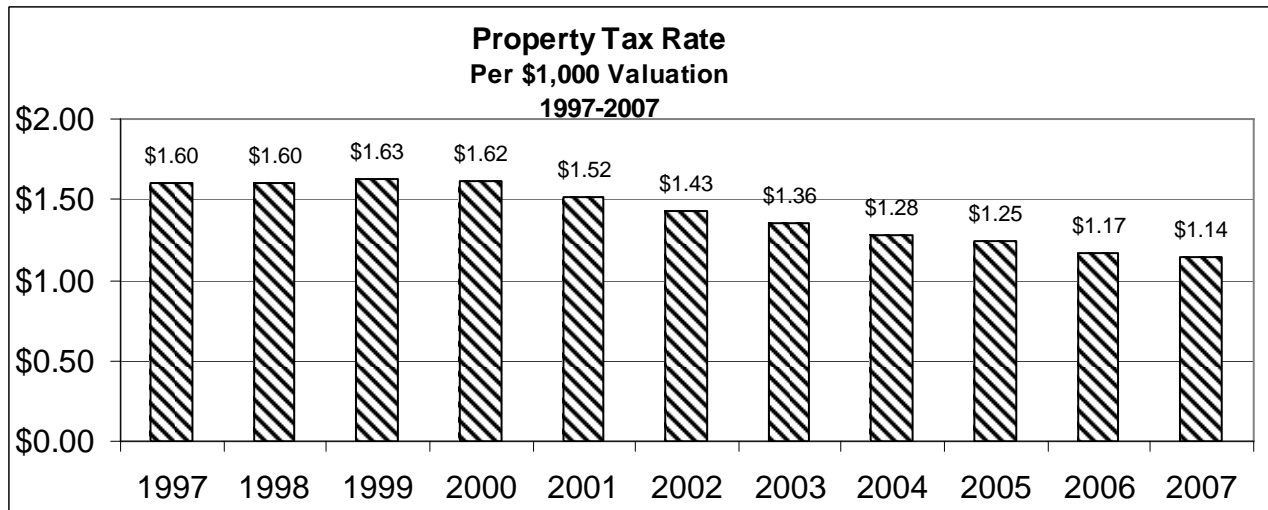

What a City Property Owner Pays in 2006

Property Tax Rate

	City	King County	Shoreline Schools	State Schools	Fire District	Library District	Port of Seattle	King County EMS	Total
Rate	1.17	1.32	4.11	2.49	1.67	0.54	0.25	0.23	11.78
%	9.93%	11.21%	34.89%	21.14%	14.18%	4.58%	2.12%	1.95%	100.0%

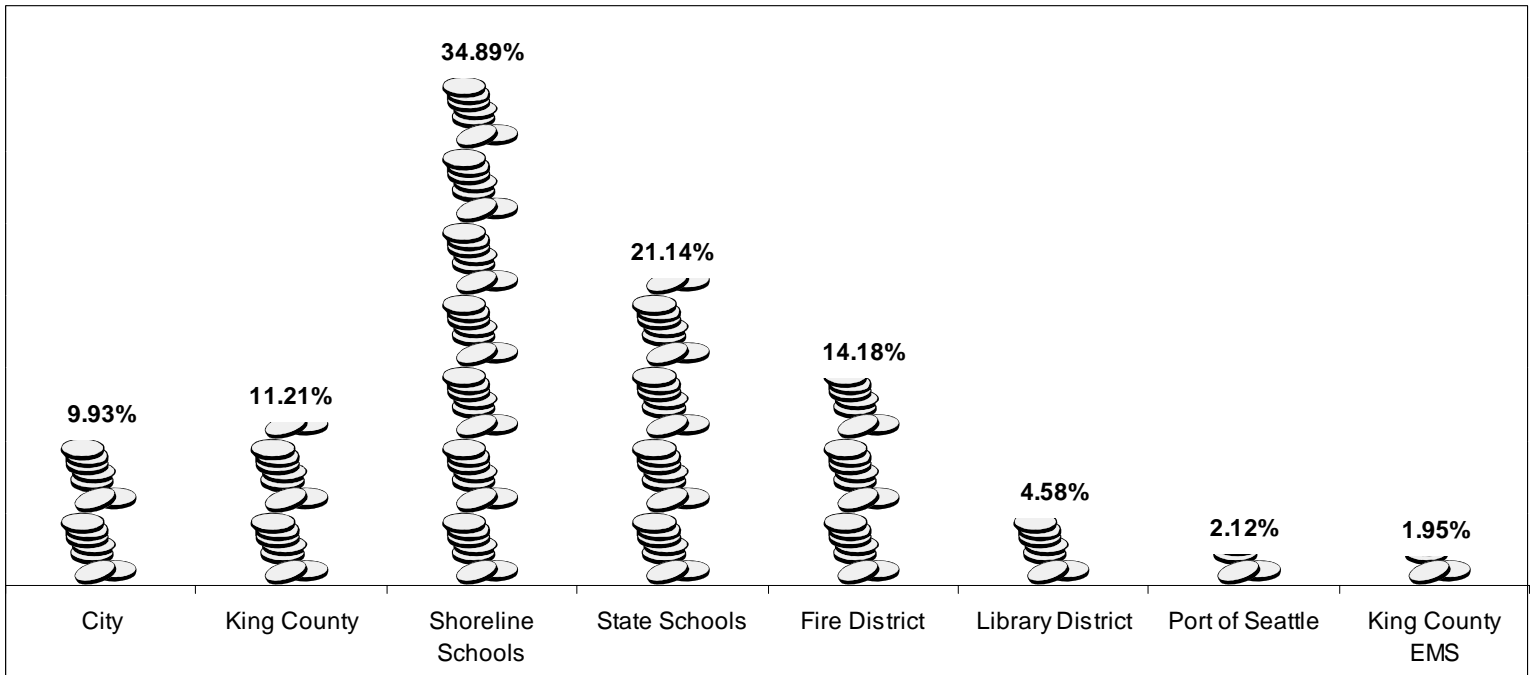

The chart below illustrates the City property tax portion payable in 2006 by an individual owning a home valued at \$314,000. Based on the 2006 property tax rate, only 9.93% of the homeowner's property tax will be distributed to the City.

Taxing Jurisdiction	Assessed Value	Per \$1,000 (AV/\$1,000)	Rate	Assessment	%
City	\$ 314,000	314	X	\$ 1.17 = 367.38	9.93%
King County	\$ 314,000	314	X	1.32 = 414.48	11.21%
Shoreline School District	\$ 314,000	314	X	4.11 = 1,290.54	34.89%
State Schools	\$ 314,000	314	X	2.49 = 781.86	21.14%
Fire District	\$ 314,000	314	X	1.67 = 524.38	14.18%
Library District	\$ 314,000	314	X	0.54 = 169.56	4.58%
Port of Seattle	\$ 314,000	314	X	0.25 = 78.50	2.12%
King Co. Emergency Med	\$ 314,000	314	X	0.23 = 72.22	1.95%
TOTAL				\$ 11.78 = 3,698.92	100.0%

Property Tax Charts

2004 Actual	2005 Actual	2006 Projected	2007 Budget	Forecast 2008	Forecast 2009	Forecast 2010	Forecast 2011	Forecast 2012
\$6,714,339	\$6,822,871	\$6,935,415	\$7,066,510	\$7,181,085	\$7,295,541	\$7,409,913	\$7,524,236	\$7,638,543
Annual Change	\$108,532	\$112,544	\$131,095	\$114,575	\$114,456	\$114,372	\$114,323	\$114,307
% Increase	1.62%	1.65%	1.89%	1.62%	1.59%	1.57%	1.54%	1.52%

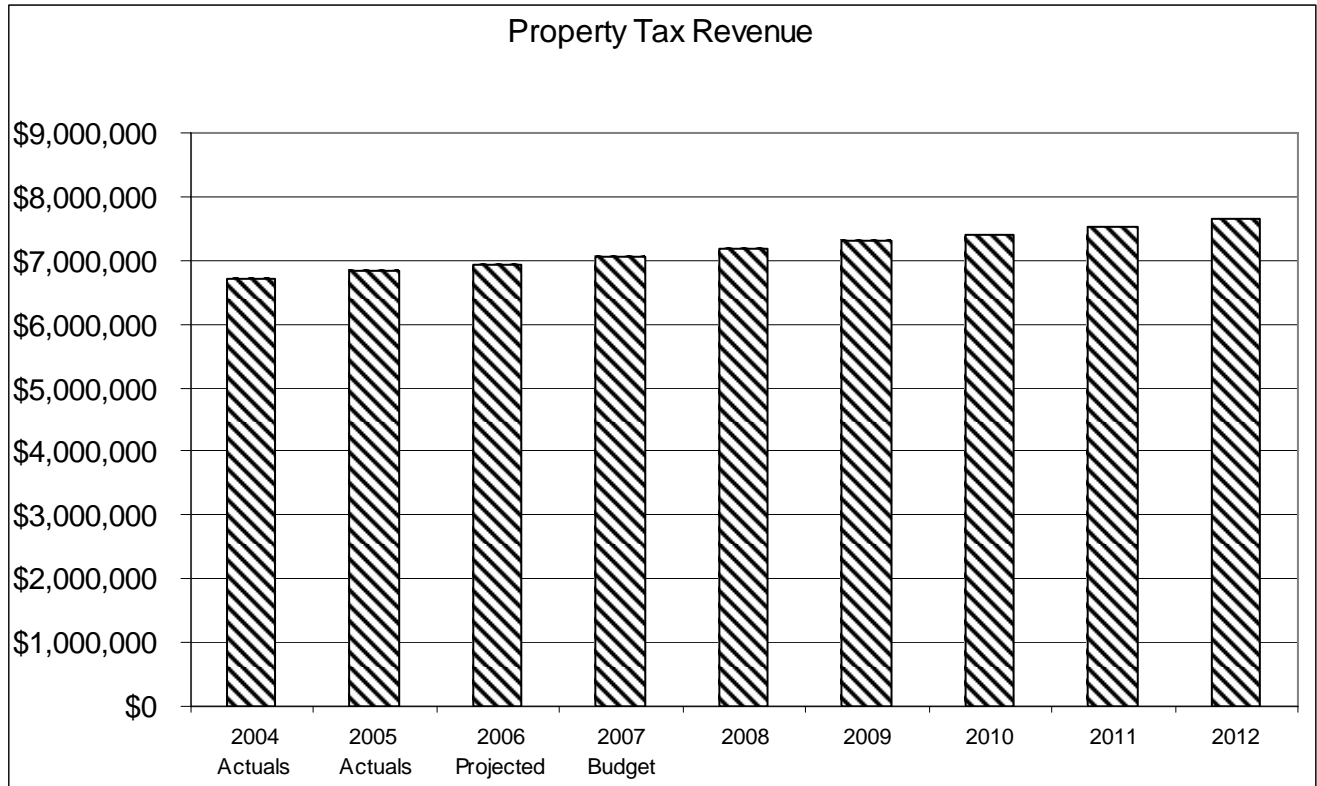

Sales Tax

Actual collections in 2005 totaled \$5,996,455. This was an increase of \$233,245 or 4.05% over actual collections in 2004. Projected collections of sales tax revenue for 2006 total \$6,086,402. This is a \$89,947, or 1.5%, increase from 2005.

Through the first half of 2006 sales tax revenue is tracking less than 1% above the same period in 2005 but is 4.4% ahead of budgeted 2006 revenue. The 2007 sales tax revenue is expected to increase by 2.69% from the projected 2006 amount of \$6,086,401 to \$6,250,000. At this level, sales tax revenues will account for 23.4% of the total 2007 General Fund operating revenues.

Since 2001, annual growth has averaged 3.1% on a real dollar basis. For this reason, and due to the makeup of the City's tax base, we will continue to be conservative in our projections. For future years, we are projecting a rate of growth of 4.65% in 2008, 4.58% in 2009, 3.90% in 2010, 3.98% in 2011 and 3.98% in 2012.

Sales Tax Charts

2004 Actual	2005 Actual	2006 Projected	2007 Budget	Forecast 2008	Forecast 2009	Forecast 2010	Forecast 2011	Forecast 2012
\$5,763,210	\$5,996,455	\$6,086,402	\$6,250,000	\$6,540,625	\$6,840,186	\$7,106,953	\$7,389,810	\$7,683,924
Annual Change	\$233,245	\$89,947	\$163,598	\$290,625	\$299,561	\$266,767	\$282,857	\$294,114
% Change	4.05%	1.50%	2.69%	4.65%	4.58%	3.90%	3.98%	3.98%

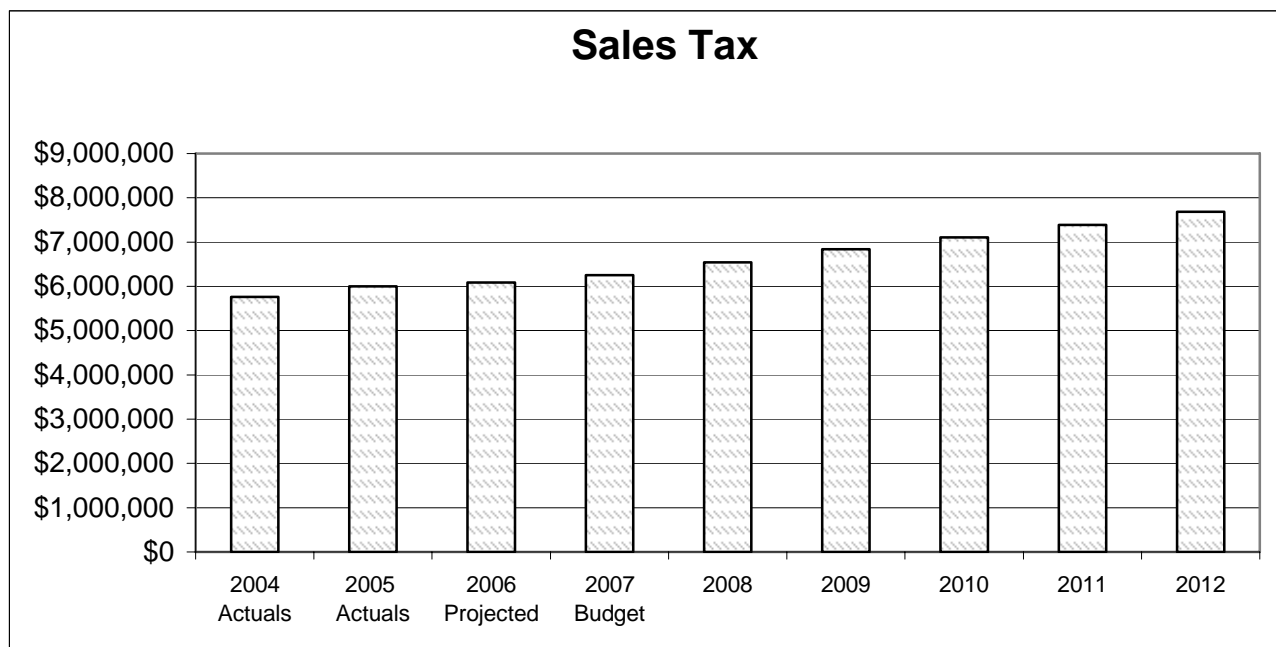

Gambling Tax

Gambling tax rate limits are set by the state and vary by game. In 1998, the State allowed the opening of “mini-casinos” and expanded the number of cardrooms and the betting limits. This expansion resulted in 76% and 48% revenue increases in 1998 and 1999. For the next few years, gambling tax revenues stabilized at around \$2.5 million. A new mini-casino was opened during the fourth quarter of 2003. This resulted in a total collection of \$2.86 million in 2003. Actual revenue for 2004 totaled \$3,321,060 an increase over the prior year of \$465,779.

In 2005 the City lowered its tax rate on card games from 11% to 10% and in 2006 the tax rate was further lowered to 7% for a nine month period beginning in July. The reduction from 10% to 7% is a temporary reduction. The card room gambling tax rate is expected to go back up to 10% in the second quarter of 2007. The reduction was made in response to concerns about the economic viability of the gambling industry within Shoreline due to competition from tribal gaming, a newly enacted state-wide smoking ban in public places and a major road construction project along Aurora Avenue in Shoreline. Gross receipts for card rooms were 20% less during the first half of 2006 when compared to the same period in 2005. The goal of the tax reduction is to enable the casinos to operate in a profitable position as business recovers from the impacts of the road construction and the smoking ban.

The City Council has a policy to retain only an amount equal to a 7% tax rate in the General Fund’s on-going revenue base. An amount equal to the remaining 3% is transferred to Capital Funds to be used for one-time capital improvements. This policy was adopted in response to several attempts by the State Legislature to lower the allowable City tax rate. The City Council policy limits the General Fund’s reliance on this revenue source for general operations of the City.

The City’s gambling tax revenues come from card room, bingo and pull-tab activity. The major facility that operated bingo in the City closed in 2006. This eliminated \$44,000 in on-going gambling tax revenue.

The 2007 forecast is based on the new tax rate and is somewhat conservative based on the slowing gambling economy in Shoreline. Projected gambling tax revenue for 2007 equals 8.0% of the total forecasted General Fund operating revenue.

Gambling Tax Charts

2004 Actual	2005 Actual	2006 Projected	2007 Budget	Forecast 2008	Forecast 2009	Forecast 2010	Forecast 2011	Forecast 2012
\$3,321,060	\$3,003,004	\$2,053,800	\$2,134,500	\$2,273,089	\$2,264,765	\$2,256,856	\$2,249,342	\$2,242,205
Annual Change	(\$318,056)	(\$949,204)	\$80,700	\$138,589	(\$8,324)	(\$7,909)	(\$7,514)	(\$7,137)
% Change	-9.58%	-31.61%	3.93%	6.49%	-0.37%	-0.35%	-0.33%	-0.32%

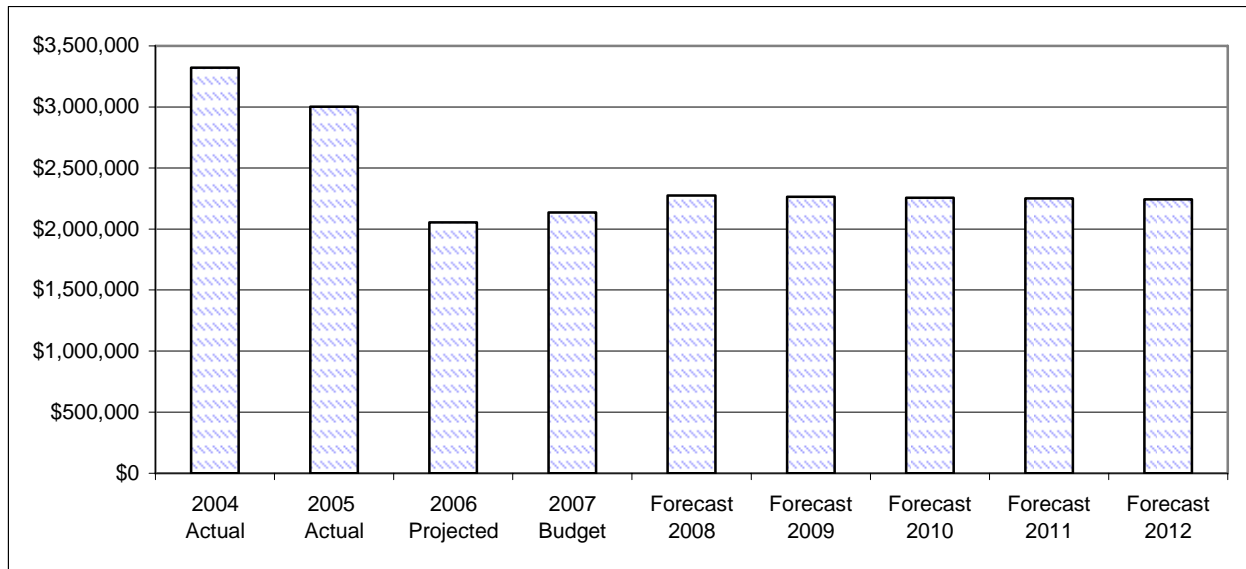

Utility Taxes

The Council enacted a 6% utility tax on natural gas, telephone, cellular telephone, pager services, and sanitation services along with a 1% utility tax on cable effective in 2000 and in 2005 a 6% utility tax was applied to storm drainage. Projected revenues in 2007 from utility taxes are \$3,215,000 or 12% of the total General Fund operating revenues. This is an increase of \$295,500 or 10.12% over projected 2006 utility tax revenues of \$2,919,500.

In the natural gas category, 2007 revenues of \$1,045,000 are projected to increase by 22.94% over 2006 projected revenues of \$850,000. Total collections in 2005 were \$837,333. Puget Sound Energy (PSE) implemented overall rate increases of 17.8% in late 2005 and received approval for a 9% rate increase effective October 1, 2006.

Revenues from telephone, cellular, and pager services are expected to increase by 5.07% in 2007 for a total of \$1,555,000. 2006 projected revenue is \$1,480,000. Growth is projected between 2.4% and 2.7% for future years. This forecast remains somewhat conservative as new technologies develop. Currently federal legislation prohibits the City from levying a utility tax on telecommunication activities that occur via the internet. As more consumers use this form of technology for telecommunications, the City may experience a decline in utility tax revenue.

Sanitation utility tax revenues for 2007 are projected to increase by 2.72% or \$9,000 over 2006 projections. Revenue is expected to total \$340,000 in 2007. 2006 projected collections should total \$331,000. Future growth is projected at 2.04% in 2008, 2.02% in 2009, 1.90% in 2010, 1.92% in 2011 and 1.87% in 2012.

2007 cable tax revenues are expected to increase by 2.08% over projected 2006 levels for a total of \$98,000. Revenues from cable television are expected to grow in the future at a rate of between 2.4% and 2.7% annually.

Revenues from the storm drainage utility tax are expected to increase by 8.92% or \$14,500 for a total 2007 collection of \$177,000. The 2007 proposed budget includes a requested increase for the storm drainage fee. This will result in an increase in the amount of utility tax received by the City.

Utility Tax Charts

Revenue	2004 Actual	2005 Actual	2006 Projected	2007 Budget	Forecast 2008	Forecast 2009	Forecast 2010	Forecast 2011	Forecast 2012
Natural Gas	\$693,898	\$837,333	\$850,000	\$1,045,000	\$1,065,900	\$1,087,218	\$1,108,962	\$1,131,142	\$1,153,764
Annual Change		\$143,435	\$12,667	\$195,000	\$20,900	\$21,318	\$21,744	\$22,179	\$22,623
% Change		20.67%	1.51%	22.94%	2.00%	2.00%	2.00%	2.00%	2.00%
Phone/Cell	\$1,480,611	\$1,649,405	\$1,480,000	\$1,555,000	\$1,597,296	\$1,640,263	\$1,681,762	\$1,724,815	\$1,767,763
Annual Change		\$168,794	(\$169,405)	\$75,000	\$42,296	\$42,967	\$41,499	\$43,053	\$42,948
% Change		11.40%	-10.27%	5.07%	2.72%	2.69%	2.53%	2.56%	2.49%
Sanitation	\$322,140	\$325,538	\$331,000	\$340,000	\$346,936	\$353,944	\$360,669	\$367,594	\$374,468
Annual Change		\$3,398	\$5,462	\$9,000	\$6,936	\$7,008	\$6,725	\$6,925	\$6,874
% Change		1.05%	1.68%	2.72%	2.04%	2.02%	1.90%	1.92%	1.87%
Cable TV	\$77,442	\$90,029	\$96,000	\$98,000	\$100,666	\$103,374	\$105,989	\$108,702	\$111,409
Annual Change		\$12,587	\$5,971	\$2,000	\$2,666	\$2,708	\$2,615	\$2,713	\$2,707
% Change		16.25%	6.63%	2.08%	2.72%	2.69%	2.53%	2.56%	2.49%
Storm Drainage	\$0	\$145,749	\$162,500	\$177,000	\$191,355	\$197,095	\$203,008	\$209,098	\$215,371
Annual Change		\$145,749	\$16,751	\$14,500	\$14,355	\$5,741	\$5,913	\$6,090	\$6,273
% Change		0.00%	11.49%	8.92%	8.11%	3.00%	3.00%	3.00%	3.00%
Total Revenue	\$2,574,091	\$3,048,054	\$2,919,500	\$3,215,000	\$3,302,152	\$3,381,894	\$3,460,390	\$3,541,351	\$3,622,776
Annual Change		\$473,963	(\$128,554)	\$295,500	\$87,152	\$79,742	\$78,496	\$80,961	\$81,424
% Change		18.41%	-4.22%	10.12%	2.71%	2.41%	2.32%	2.34%	2.30%

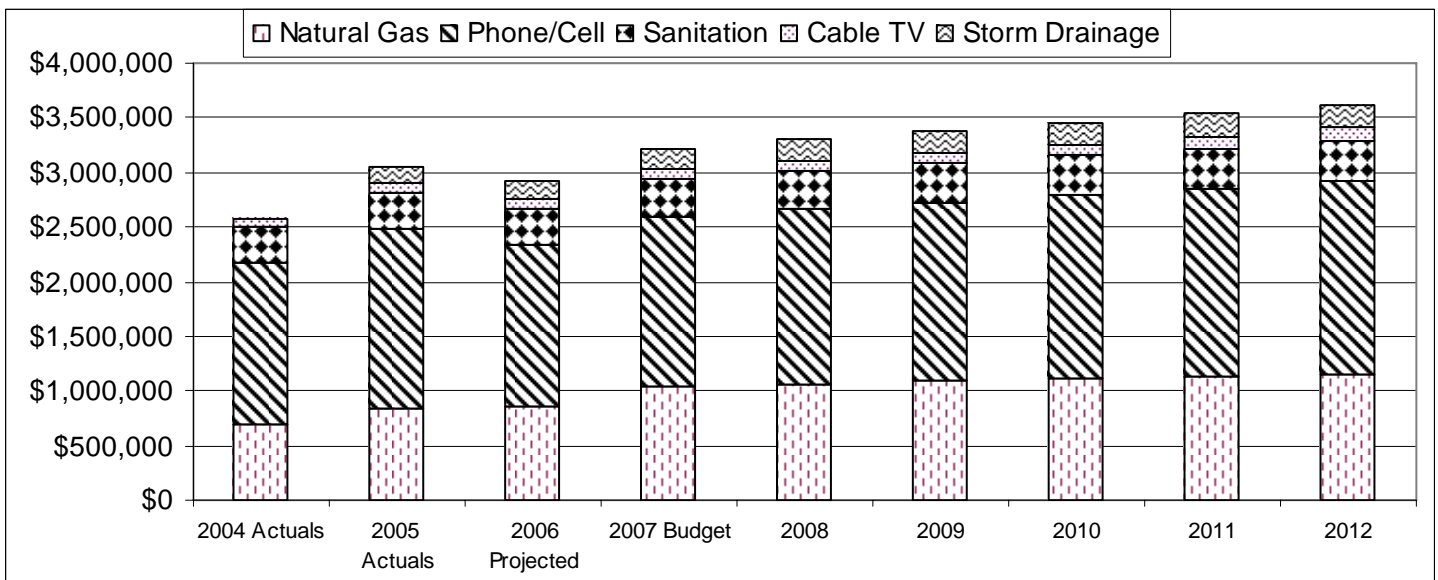

Public Utility Contract Payments /Franchise Fees

The City has entered into agreements with many of the public utilities that provide services to our citizens. Agreements have been reached with Seattle City Light, Seattle Public Utilities (Water and Sewer), Shoreline Water District, and Ronald Wastewater District. These utilities pay a contract fee to the City in an amount equal to six-percent of their revenues.

The total projected 2007 revenue from contract payments is \$2,750,595, which equates to 10.3% of the total General Fund operating revenues. This is a slight decrease of \$21,905 or 0.79% from projected 2006 revenue. Electricity contract payments from Seattle City Light are expected to remain at the same level as 2006. For the period of 2008 through 2012 we modest annual growth is projected between 1.87% and 2.04%.

Projected sewer contract payments are \$655,595 for 2007. This is based on the City's agreement with the Ronald Wastewater District. In the future the annual growth rate is projected at 3%.

Revenues from water contract payments for 2007 are expected to be \$565,000, a decrease of \$45,000 from 2006 projected revenue. Some 2005 revenue was actually received in 2006, therefore projected 2006 revenue are higher than normal. For the period of 2008 through 2012 modest annual growth is projected between 1.87% and 2.04%.

The cable television franchise fee is set at a rate equal to five-percent of gross cable service revenues. 2005 collections were \$486,924. Estimated revenue for 2006 is \$526,000. Projected revenues for 2007 total \$530,000. For the period 2008 – 2012 we are anticipating modest annual growth moderating between: 2.49% to 2.72%.

Public Utility Contract Payments/Franchise Fee Charts

	2004 Actual	2005 Actual	2006 Projected	2007 Budget	Forecast 2008	Forecast 2009	Forecast 2010	Forecast 2011	Forecast 2012
Cable TV	\$458,084	\$486,924	\$526,000	\$530,000	\$544,416	\$559,061	\$573,205	\$587,879	\$602,517
Annual Increase		\$28,840	\$39,076	\$4,000	\$14,416	\$14,645	\$14,144	\$14,674	\$14,638
% Increase		6.30%	8.03%	0.76%	2.72%	2.69%	2.53%	2.56%	2.49%
Sewer	\$603,000	\$621,000	\$636,500	\$655,595	\$675,263	\$695,521	\$716,386	\$737,878	\$760,014
Annual Increase		\$18,000	\$15,500	\$19,095	\$19,668	\$20,258	\$20,866	\$21,492	\$22,136
% Increase		2.99%	2.50%	3.00%	3.00%	3.00%	3.00%	3.00%	3.00%
Water	\$430,170	\$610,943	\$610,000	\$565,000	\$576,526	\$588,172	\$599,347	\$610,855	\$622,278
Annual Increase		\$180,773	-\$943	-\$45,000	\$11,526	\$11,646	\$11,175	\$11,507	\$11,423
% Increase		42.02%	(0.15%)	(7.38%)	2.04%	2.02%	1.90%	1.92%	1.87%
Electricity	\$1,066,780	\$1,032,548	\$1,000,000	\$1,000,000	\$1,020,400	\$1,041,012	\$1,060,791	\$1,081,159	\$1,101,376
Annual Increase		-\$34,232	-\$32,548	\$0	\$20,400	\$20,612	\$19,779	\$20,367	\$20,218
% Increase		(3.21%)	(3.15%)	0.00%	2.04%	2.02%	1.90%	1.92%	1.87%
Total Utility Contract Payment	\$2,558,034	\$2,751,415	\$2,772,500	\$2,750,595	\$2,816,605	\$2,883,765	\$2,949,730	\$3,017,770	\$3,086,185
Annual Change		\$193,381	\$21,085	-\$21,905	\$66,010	\$67,161	\$65,964	\$68,040	\$68,415
% Change		7.56%	0.77%	-0.79%	2.40%	2.38%	2.29%	2.31%	2.27%

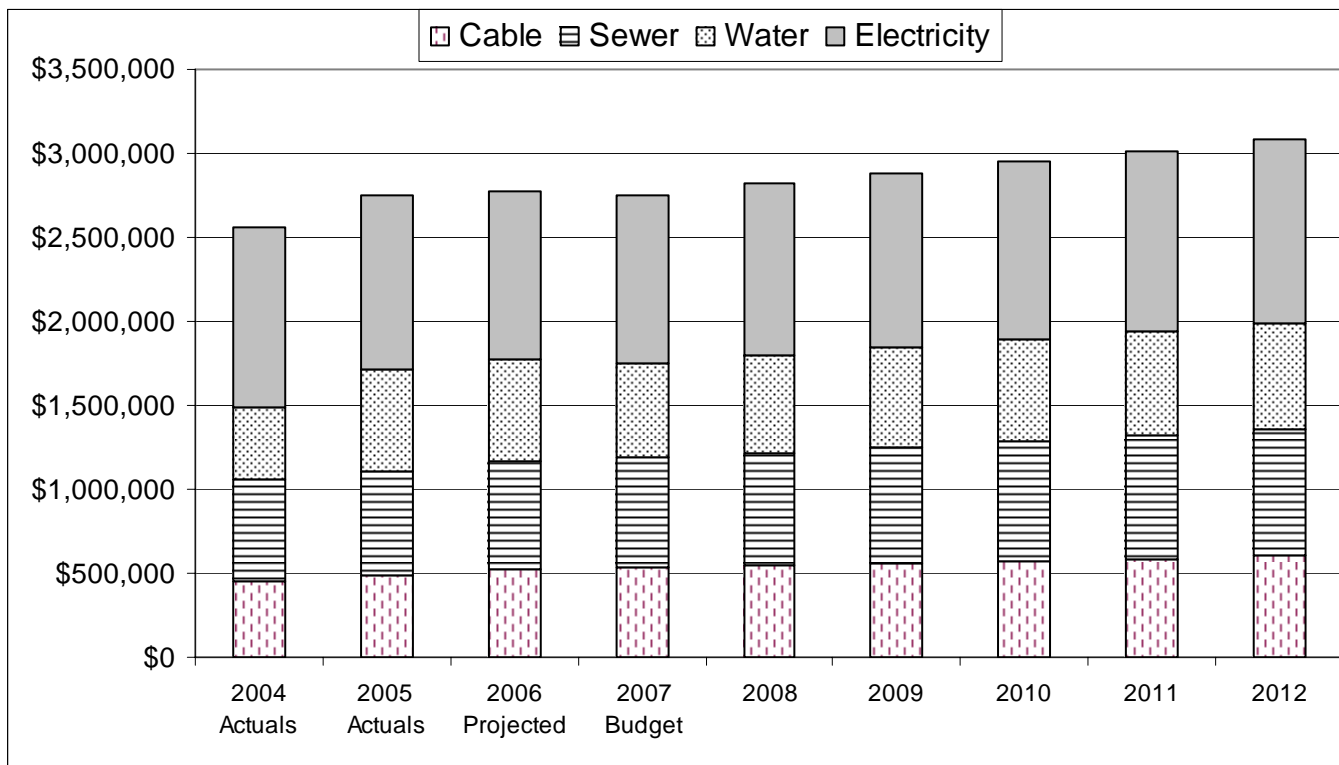

Recreation Fees

Parks and recreation programs offered by the City are partially supported through user fees. In 2000, parks and recreation fee schedules were adjusted for the first time since incorporation. These fee revisions were based upon the annual update of the City's overhead allocation plan, user fee reviews and a thorough review of the parks, recreation, and teen program fee structures. The fee schedule update was intended to establish a balanced fee approach while retaining market competitiveness with the City's surrounding jurisdictions. Fees continue to be reviewed on an annual basis. The 2005 budget included several fee adjustments and the establishment of a resident discount. In 2006 fees were adjusted for inflation and due to capital improvements to some of our athletic field rentals, some field rental rates increased significantly to help cover the costs of the improvements. In 2007 the Parks fee schedule will include inflationary increases and some other adjustments to more adequately cover increased costs.

Over the past several years the City of Shoreline's recreation and aquatics programs saw significant revenue increases due to the popularity of its programs and to the extensive array of programming offered. As a result, in 2004 revenue increased by \$80,842 or 11% over the previous year, in 2005 the increase was \$167,828 or 20.53% and in 2006 it is projected to increase by \$117,267 or 11.9%. For 2007 the revenue increase is much more modest just \$33,778 or 3.06%. The flattening of the revenue growth trend is due to the fact that many of our parks programs are running at maximum capacity with very little or no room for expansion.

Projected 2007 revenue from parks and recreation fees is \$1,136,288 or 4.2% of the total General Fund operating revenues. This is 3.06% more than the 2006 projected revenue of \$1,102,510. Projected revenue for 2007 is based upon the current level of activity and participation in parks programs that is occurring in 2006. During 2007, revenues from the general recreation activities are projected to increase by \$19,048 or 3.89%. Aquatics revenues are expected to decrease just slightly by \$4,001 or 1.12%. Most aquatic program revenue is expected to stay flat with the exception of a reduction in revenue from fitness classes. Revenues from facility rentals are expected to grow by \$20,300 or 9.46% due to the installation of new field turf on two of the City's most popular soccer fields, this enhancement will allow for scheduling more games and practices and also charging higher fees. Projected 2007 revenue from teen activities is down slightly by \$1,569 or 3.86%. Overall, recreation fee revenue is projected to grow by 2.04% in 2008, 2.02% in 2009 and 1.90% for years 2010, 1.92% in 2011 and 1.87% in 2012.

Recreation Fee Charts

	2004 Actual	2005 Actual	2006 Projected	2007 Budget	Forecast 2008	Forecast 2009	Forecast 2010	Forecast 2011	Forecast 2012
Recreation	\$270,637	\$400,386	\$489,134	\$508,182	\$518,549	\$529,024	\$539,075	\$549,425	\$559,700
Annual Increase		\$129,749	\$218,497	\$19,048	\$10,367	\$10,475	\$10,051	\$10,350	\$10,274
% Increase		47.94%	80.73%	3.89%	2.04%	2.02%	1.90%	1.92%	1.87%
Aquatics	\$329,464	\$351,507	\$358,051	\$354,050	\$361,273	\$368,570	\$375,573	\$382,784	\$389,942
Annual Increase		\$22,043	\$6,544	-\$4,001	\$7,223	\$7,298	\$7,003	\$7,211	\$7,158
% Increase		6.69%	1.86%	(1.12%)	2.04%	2.02%	1.90%	1.92%	1.87%
Facility Rentals	\$179,352	\$200,189	\$214,700	\$235,000	\$239,794	\$244,638	\$249,286	\$254,072	\$258,823
Annual Increase		\$20,837	\$14,511	\$20,300	\$4,794	\$4,844	\$4,648	\$4,786	\$4,751
% Increase		11.62%	7.25%	9.46%	2.04%	2.02%	1.90%	1.92%	1.87%
Teen	\$37,962	\$33,161	\$40,625	\$39,056	\$39,853	\$40,658	\$41,430	\$42,226	\$43,015
Annual Increase		-\$4,801	\$7,464	-\$1,569	\$797	\$805	\$772	\$795	\$790
% Increase		(12.65%)	22.51%	(3.86%)	2.04%	2.02%	1.90%	1.92%	1.87%
Total Recreation Fee	\$817,415	\$985,243	\$1,102,510	\$1,136,288	\$1,159,468	\$1,182,890	\$1,205,364	\$1,228,507	\$1,251,481
Annual Change		\$167,828	\$117,267	\$33,778	\$23,180	\$23,421	\$22,475	\$23,143	\$22,973
% Change		20.53%	11.90%	3.06%	2.04%	2.02%	1.90%	1.92%	1.87%

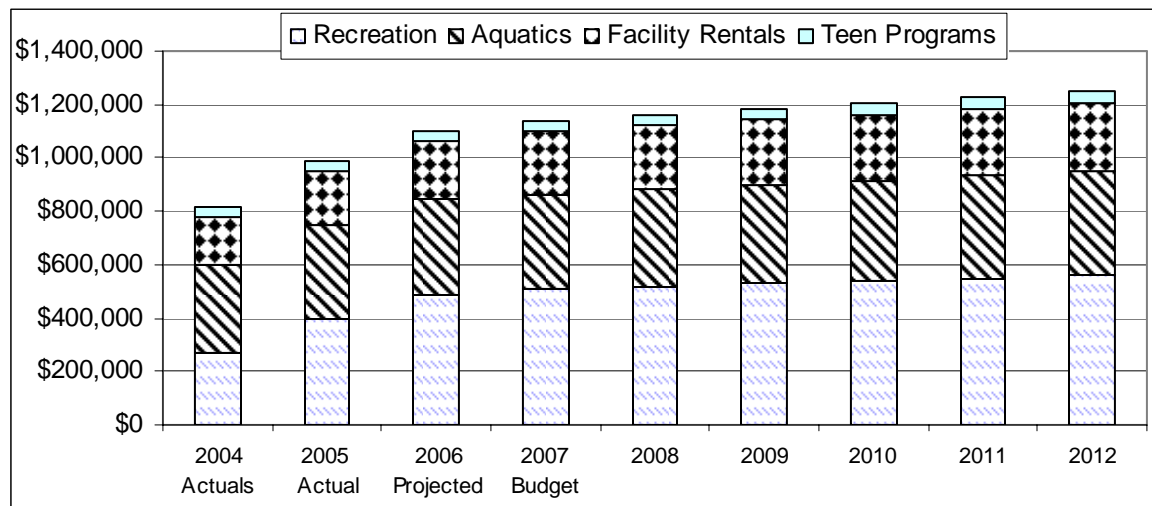

Criminal Justice Funding

There are two sources of dedicated funding for local criminal justice programs: an optional County sales tax of 0.1% and State criminal justice funding. The State funding, prior to 2000, consisted of a combination of Motor Vehicle Excise Tax (MVET) and State General Fund dollars. Due to the repeal of the MVET by the State legislature, the MVET portion was eliminated, subsequently; the only state funding anticipated is from the State's General Fund.

The projected 2007 revenue for Criminal Justice is \$1,341,469 or 5.0% of the total General Fund operating revenues. This represents an increase of \$81,385, 6.5% more than 2006 projected collections. The largest revenue source in this category is the Criminal Justice Retail Sales tax, which has been increasing slightly during the past few years as a result of a slowly rebounding King County economy. This tax is collected at the county level and distributed to the cities on a per capita basis. As the Puget Sound area continues to have positive economic growth this revenue sources is expected to grow 2.5% annually.

The remainder of this category is made up of special revenue received from the State of Washington. These revenues have been falling each year. During the 2003 legislative session, three of the special programs were combined into one overall program and the funding level was reduced. We do not expect the level of funding to increase significantly over the next few years.

Criminal Justice Funding Charts

	2004 Actual	2005 Actual	2006 Projected	2007 Budget	Forecast 2008	Forecast 2009	Forecast 2010	Forecast 2011	Forecast 2012
Retail Sales - Criminal Justice	\$1,035,325	\$1,111,985	\$1,150,687	\$1,224,500	\$1,278,242	\$1,333,215	\$1,383,175	\$1,437,600	\$1,494,166
State - Criminal Justice - Per Capita	\$9,491	\$9,763	\$7,447	\$11,663	\$11,681	\$11,178	\$11,206	\$11,234	\$11,262
State - Criminal Justice - City Law Enforcement	\$57,916	\$67,465	\$65,155	\$65,155	\$65,155	\$65,155	\$65,155	\$65,155	\$65,155
Criminal Justice - Special Programs	\$38,176	\$38,927	\$36,795	\$40,151	\$39,376	\$39,376	\$39,376	\$39,376	\$39,376
Total Criminal Justice	\$1,140,908	\$1,228,140	\$1,260,084	\$1,341,469	\$1,394,454	\$1,448,924	\$1,498,912	\$1,553,365	\$1,609,959
Annual Change		\$87,232	\$31,944	\$81,385	\$52,985	\$54,470	\$49,988	\$54,453	\$56,594
% Change		7.6%	2.6%	6.5%	3.9%	3.9%	3.5%	3.6%	3.6%

Criminal Justice Funding Charts continued

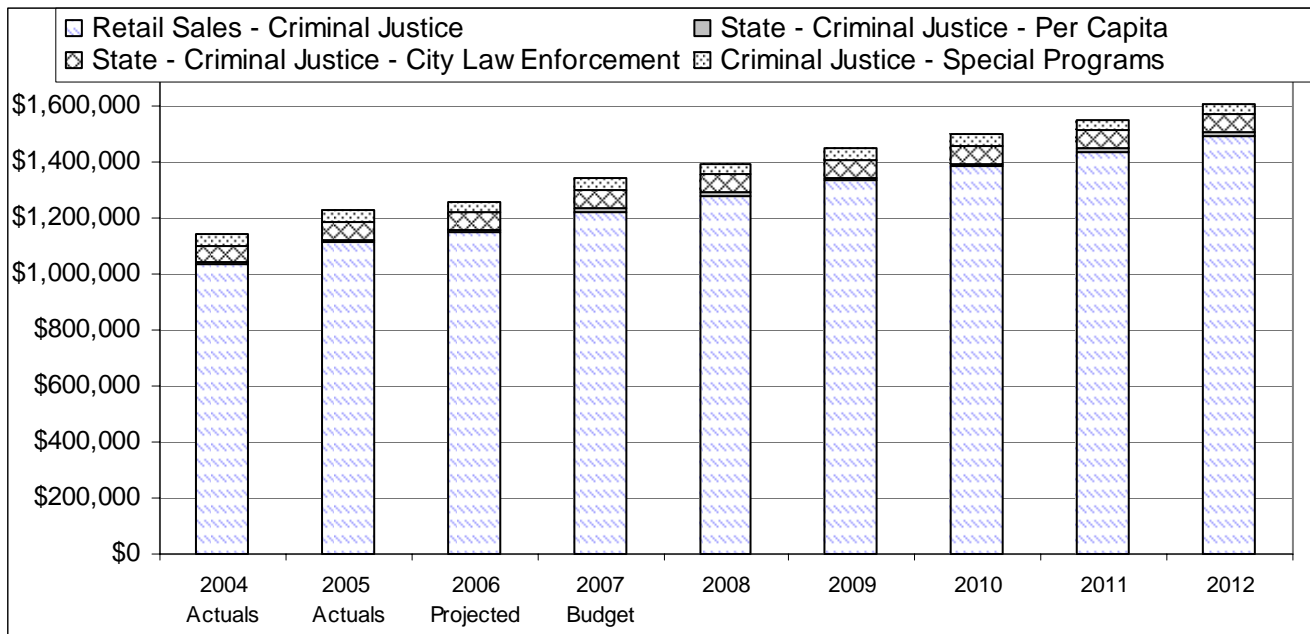

Liquor Excise Tax & Board Profits

The City receives a portion of the liquor excise tax receipts collected by the State of Washington. The City also receives a portion of the profits of the State Liquor Board. 2006 projected revenue is less than expected because the State Legislature increased appropriations to the Liquor Control Board for a number of new initiatives and programs. These ventures are all intended to increase profits in the future by increasing revenues or decreasing costs. Their short term effect, however, was to reduce profits for distribution in calendar years 2005 and 2006.

The liquor excise tax and board profit revenues are distributed on a per capita basis. The projected 2007 revenue from these two sources is \$618,175, which is an increase of \$57,835 or 10.32% from 2006 projected revenues. This projection is based upon the estimated per capita rates that have been provided by Municipal Research Services Center. The forecast for future years is based on conservative growth of 2.5% annually.

Liquor Tax Charts

2004 Actual	2005 Actual	2006 Projected	2007 Budget	Forecast 2008	Forecast 2009	Forecast 2010	Forecast 2011	Forecast 2012
\$586,331	\$589,856	\$560,340	\$618,175	\$648,509	\$663,530	\$678,075	\$693,067	\$708,046
Annual Change	\$3,525	(\$29,516)	\$57,835	\$30,334	\$15,021	\$14,545	\$14,992	\$14,979
% Increase	0.60%	-5.00%	10.32%	4.91%	2.32%	2.19%	2.21%	2.16%

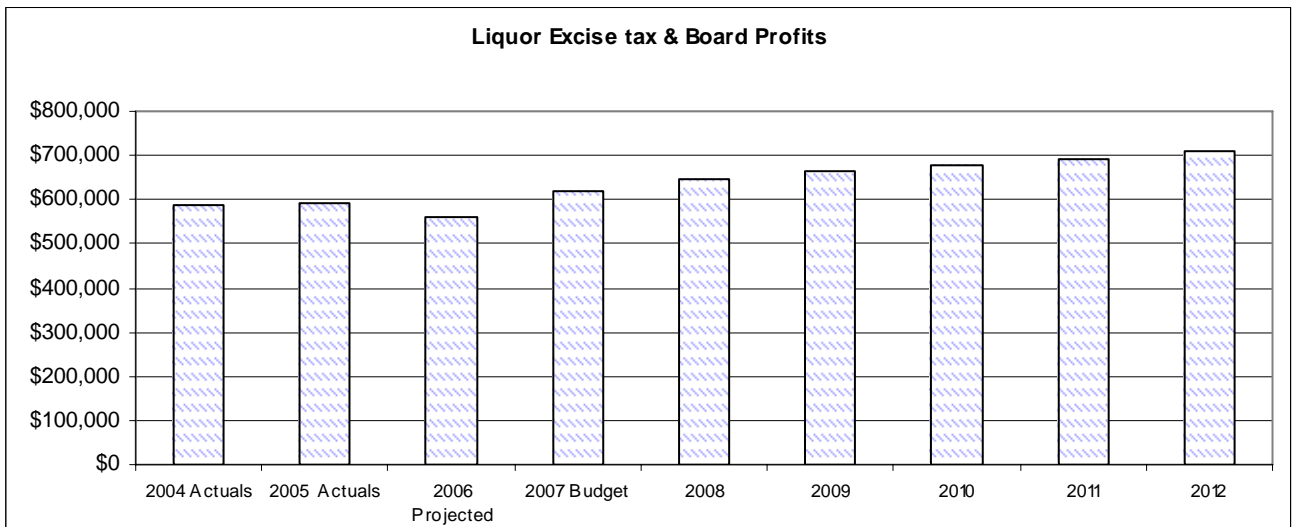

Grants

In 2007, Shoreline is projected to receive \$234,316 in grant funding from a variety of sources to support health and human services programs, traffic enforcement, recycling programs, and recreation programs. The City is projecting to receive \$365,113 in grants during 2006. Typically, the largest grants received in the General Fund are for the Community Development Block Grant (CDBG) which funds various human services.

Development Permit Fees

Fees are charged for a variety of development permits obtained through the City's Planning and Development Services Department. These include building, structure, plumbing, electrical, and mechanical permits; land use permits; permit inspection fees; plan check fees; and fees for environmental reviews. In 2007, revenues are projected to be \$1,295,335. This is an increase of \$11,572 or less than one percent from 2006 projected revenues. As the housing market is projected to slow, the City has conservatively projected that permit revenues may decline over the next few years.

Building permit revenue, and the associated plan check revenue, is a significant portion of the development permit revenue. The following is information on the number of building permits and the valuation of the improvements that have been issued for residential, commercial and multi-family for 2001 through August 2006:

	Residential				Commercial				Multi-Family			
	New Residential		Add/Remodel Residential		New Commercial		Add/Remodel Commercial		New Multi-Family		Add/Remodel Multi-Family	
	Number	Valuation	Number	Valuation	Number	Valuation	Number	Valuation	Number	Valuation	Number	Valuation
2006 (1)	36	10,278,881	148	6,017,114	7	14,019,490	22	1,768,823	18	7,274,459	3	112,294
2005	64	18,632,605	190	9,106,623	12	19,499,583	63	11,662,368	19	14,646,526	16	372,975
2004	57	7,990,568	179	6,502,577	9	12,831,853	54	4,019,805	7	8,343,302	2	98,600
2003	77	13,952,978	204	6,670,855	8	5,747,717	56	7,517,594	6	3,804,853	6	412,191
2002	75	13,139,618	179	6,966,343	7	7,202,078	45	3,697,389	16	6,679,036	9	765,004
2001	71	14,872,024	161	6,682,787	4	369,600	40	5,473,349	4	1,801,968	4	163,400

(1) Through August 2006

Development Permit Fee Charts

2004 Actual	2005 Actual	2006 Projected	2007 Budget	Forecast 2008	Forecast 2009	Forecast 2010	Forecast 2011	Forecast 2012
\$1,021,376	\$1,337,454	\$1,280,763	\$1,292,335	\$1,186,052	\$1,177,261	\$1,134,458	\$1,081,412	\$1,066,254
Annual Change	\$316,078	(\$56,691)	\$11,572	(\$106,283)	(\$8,790)	(\$42,804)	(\$53,046)	(\$15,158)
% Change	30.95%	-4.24%	0.90%	-8.22%	-0.74%	-3.64%	-4.68%	-1.40%

*Revenues collected prior to 2005 were recorded in the Development Services Fund.

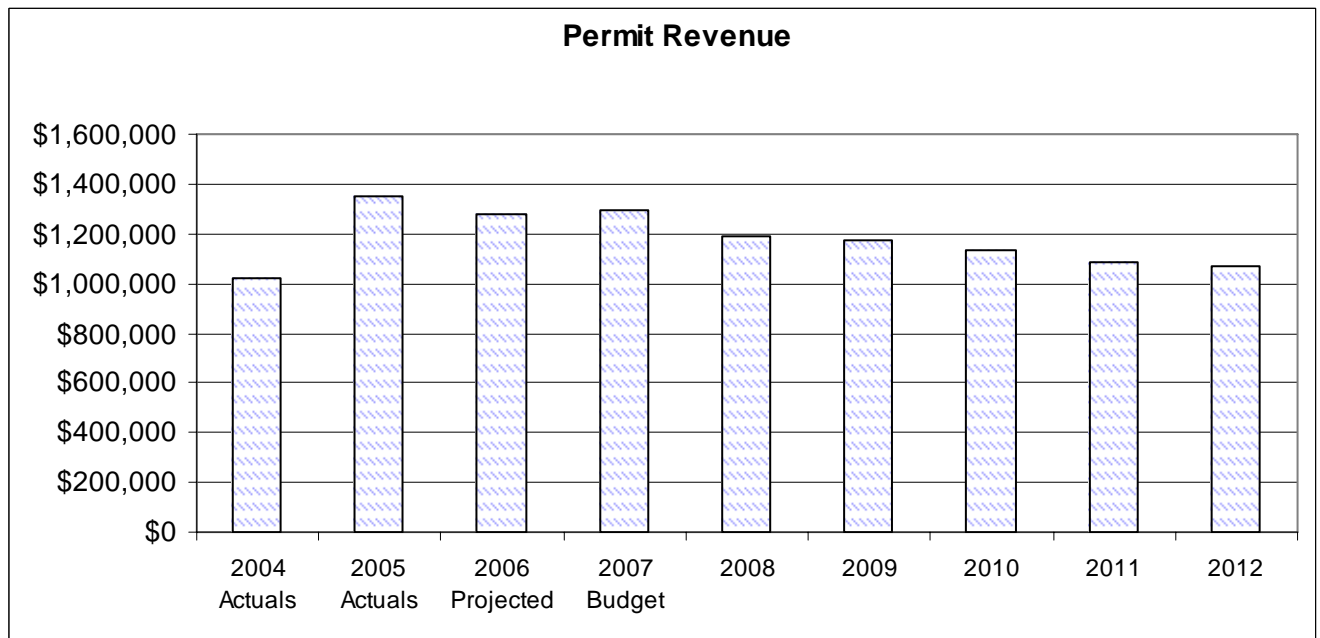

Street Fund Revenues

In the past, the major revenue sources for the maintenance of the City's streets have been motor vehicle fuel tax, county vehicle license fees and beginning in 2002, right-of-way permit fees. These three sources alone, however, are not sufficient to fully fund the street maintenance needs. As a result, the General Fund must subsidize the City's street maintenance programs. In 2002 this subsidy was \$1,420,529. In November of 2002, Washington state voters approved Initiative 776 (I-776). This initiative repealed the local vehicle license fee that had been collected by King County and distributed to local cities. This resulted in a loss of nearly \$485,000 or 34.6% of the Street Fund's 2003 operating revenues. In response to this loss, operating expenditure reductions were made totaling \$184,000 and capital expenditures were reduced by \$300,000, in order to increase the General Fund subsidy for street operations. The total subsidy was \$1,465,764 in 2004, \$1,411,690 in 2005, \$1,565,131 projected for 2006 and \$1,400,121 in 2007. The decrease in 2007 is a result of reductions made in expenditures related to street sweeping as the City begins to provide this service in-house versus a contract service.

Fuel Tax

State collected gasoline and diesel fuel tax is shared with cities and towns on a per capita basis. This revenue is to be used for street and arterial street repairs and maintenance. Projected fuel tax revenue for 2006 is \$1,291,973, this is an increase from 2005 of \$202,492. In 2005 the State Legislature enacted increased a fuel tax increase with a portion of the increased dedicated to local road maintenance. This is the primary reason for the increase in 2006 revenues.

The projected revenue for 2007 shows a much more modest increase of just \$40,384 or 3.1%. The tax is a flat amount per gallon sold. Since receipts in this category are dependent on consumption and not price it is anticipated that significant increase in gas prices may decrease the amount of fuel sold. Due to the unpredictability of fuel prices we are projecting annual revenue increases from 2.1% to 2.3%.

In the past, approximately 68% of the revenue was required to be spent on street maintenance. This was deposited into the Street Fund. The remaining funds were restricted to construction, improvement and repair of arterials and city streets. This portion was deposited into the Arterial Street Fund and then transferred to the Roads Capital Fund to support the annual road surface maintenance project. The State Legislature eliminated the restrictions on the use of fuel tax revenues during the 2005 legislative session. The City will continue to deposit 68% of the original distribution into the City's Street Fund for ongoing street maintenance activities. The remaining 32% and the new tax will be deposited directly into the Roads Capital Fund to support the annual road surface maintenance project. The new fuel tax will help to offset the loss of the local vehicle license fee.

Fuel Tax Charts

2004 Actual	2005 Actual	2006 Projected	2007 Budget	Forecast 2008	Forecast 2009	Forecast 2010	Forecast 2011	Forecast 2012
\$1,085,914	\$1,089,481	\$1,291,973	\$1,332,357	\$1,362,955	\$1,394,110	\$1,424,420	\$1,455,542	\$1,486,309
Annual Change	\$3,567	\$202,492	\$40,384	\$30,598	\$31,155	\$30,310	\$31,122	\$30,767
% Change	0.33%	18.6%	3.1%	2.3%	2.3%	2.2%	2.2%	2.1%

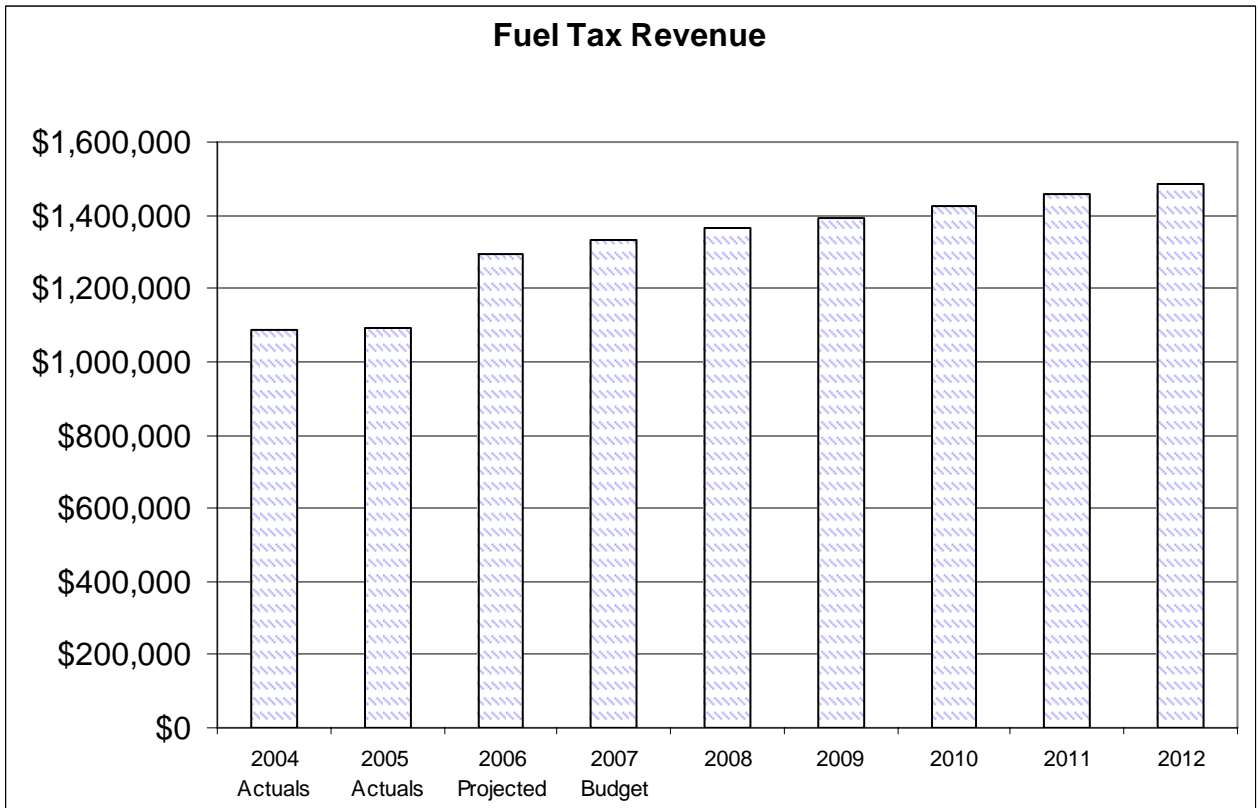

Right-of-Way Permit Fees

Fees are charged for the use of the City’s right-of-way. Prior to 2002, these revenues were reported with other development fee revenue in the Development Services Fund. In 2002, all right-of-way activity was transferred to the City’s Street Fund. Collections in 2002 totaled \$128,119, with \$114,814 in 2003, \$103,132 in 2004, \$213,514 in 2005 and projected revenues of \$111,469 for 2006. This revenue source is affected by the level of construction activity occurring within the City. As history shows, collections can vary slightly from year to year based on the level of activity. 2007 revenue is expected to increase by only \$8,531 to \$120,000

Right-of-Way Charts

2004 Actuals	2005 Actuals	2006 Projected	2007 Budget	Forecast 2008	Forecast 2009	Forecast 2010	Forecast 2011	Forecast 2012
\$103,132	\$213,514	\$111,469	\$120,000	\$122,448	\$124,921	\$127,295	\$129,739	\$132,165
Annual Change	\$110,382	(\$102,045)	\$8,531	\$2,448	\$2,473	\$2,374	\$2,444	\$2,426
% Change	107.03%	(47.8%)	7.7%	2.04%	2.02%	1.9%	1.92%	1.87%

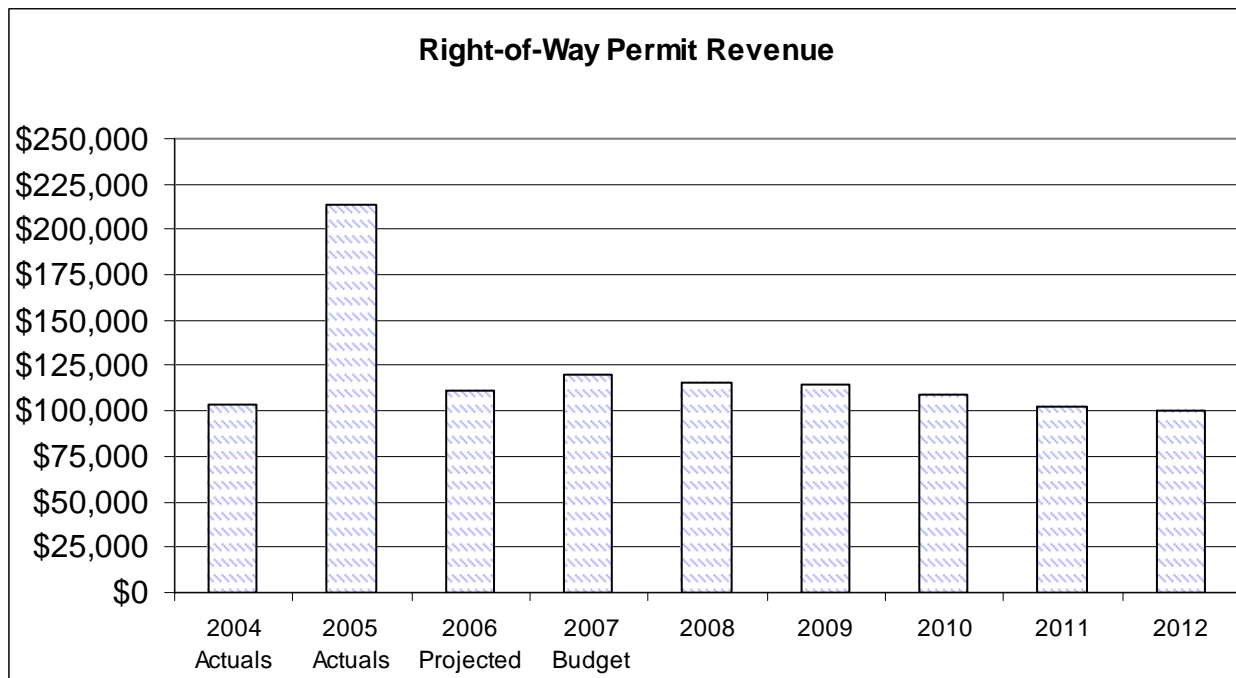

Surface Water Utility Revenues

In 2006 all surface water utility functions were accounted for in a single enterprise fund. The 2007 budget reflects this change and accounts for the surface water utility operations in a Surface Water Utility Fund. This fund includes revenue from storm drainage utility fees and investment interest.

The City contracts with King County to collect the utility revenues via the annual property tax assessments. In 2005, the City Council adopted a Surface Water Master Plan. This plan includes operational needs and capital projects for the next twenty years to improve drainage, surface water facilities, and stream habitat within the City. In order to provide the required financing for the plan, surface water fees needed to be increased. The 2006 annual rate for a single-family residence is a 8.8% increase from the 2005 rate. The Master Plan recommends that a second increase be made in 2007 of 8.11% that will raise the fee to \$120. Annual increases of .5% above inflation may be made for future years. Multi-family and commercial users are charged at a rate that reflects the area of impervious surface. These rates will be increased by the same percentages as single-family residence rate.

Projected 2006 revenues are \$2,691,567. 2007 collections are expected to increase to \$2,933,808 due to the proposed rate increase which is included in the 2007 budget. In 2007 the City will complete a fee review for the surface water utility. Currently drainage fee revenue is projected to grow by 3% annually for years 2008 through 2012.

Surface Water Enterprise Fund Revenue Charts

2004 Actual	2005 Actual	2006 Projected	2007 Budget	Forecast 2008	Forecast 2009	Forecast 2010	Forecast 2011	Forecast 2012
\$2,446,284	\$2,463,281	\$2,691,567	\$2,933,808	\$3,021,822	\$3,112,477	\$3,205,851	\$3,302,027	\$3,401,088
Annual Change	\$16,997	\$228,286	\$242,241	\$88,014	\$90,655	\$93,374	\$96,176	\$99,061
% Change	0.69%	9.27%	9.00%	3.00%	3.00%	3.00%	3.00%	3.00%

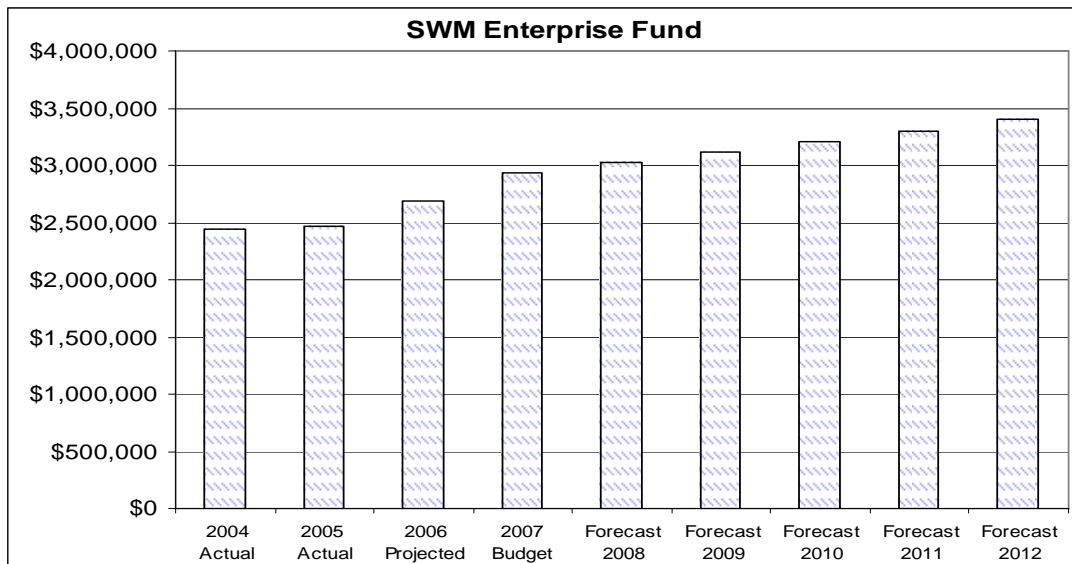

Capital Improvement Fund Revenues

Real Estate Excise Tax (REET)

All real estate property sales in the county are taxed at a rate of 1.28%. A portion of these revenues, equal to a 0.5% tax rate, is distributed to the cities by King County on a monthly basis. The use of REET funds is restricted by State law. The first 0.25% of the REET tax rate must be spent on capital projects listed in the City's Comprehensive Plan. These projects could include local capital improvements, including streets, parks, pools, municipal buildings, etc. The second 0.25% of the REET tax rate must be spent on public works projects for planning, acquisition, construction, reconstruction, repair, replacement, or improvement of streets roads, highways, sidewalks, street lighting, etc.

In 2001, Shoreline received \$1,502,980 in real estate excise tax revenues. In 2002, the City received \$1,359,470, a 9.5% decrease. In 2003, collections equaled \$1,702,913 a 25% increase over the prior year. In 2004, the City received \$2,016,595 a 18.4% increase over prior year. In 2005 the City received \$2,675,632 a 32.68% increase over 2004. These large increases were due to unprecedented growth in the price of homes and in the number of homes and commercial properties sold in Shoreline. However, real estate sales are beginning to slow in 2006 and we are expecting REET revenue to decrease in 2006 by \$725,632 or 27.1% from 2005. 2007 revenues are projected to decrease by \$230,000 or 11.8% to \$1,720,000. Projected revenue for 2007 is still well above the average annual collection experience at \$1,425,348 (pre real estate boom). We are projecting that future revenues will grow by 2% annually based upon increased property values.

Real Estate Excise Tax (REET) Charts

2004 Actual	2005 Actual	2006 Projected	2007 Budget	Forecast 2008	Forecast 2009	Forecast 2010	Forecast 2011	Forecast 2012
\$2,016,595	\$2,675,632	\$1,950,000	\$1,720,000	\$1,754,400	\$1,789,488	\$1,825,278	\$1,861,783	\$1,899,019
Annual Chg.	\$659,037	(\$725,632)	(\$230,000)	\$34,400	\$35,088	\$35,790	\$36,506	\$37,236
% Change	32.68%	-27.12%	-11.79%	2.00%	2.00%	2.00%	2.00%	2.00%

Real Estate Excise Tax (REET) Charts continued

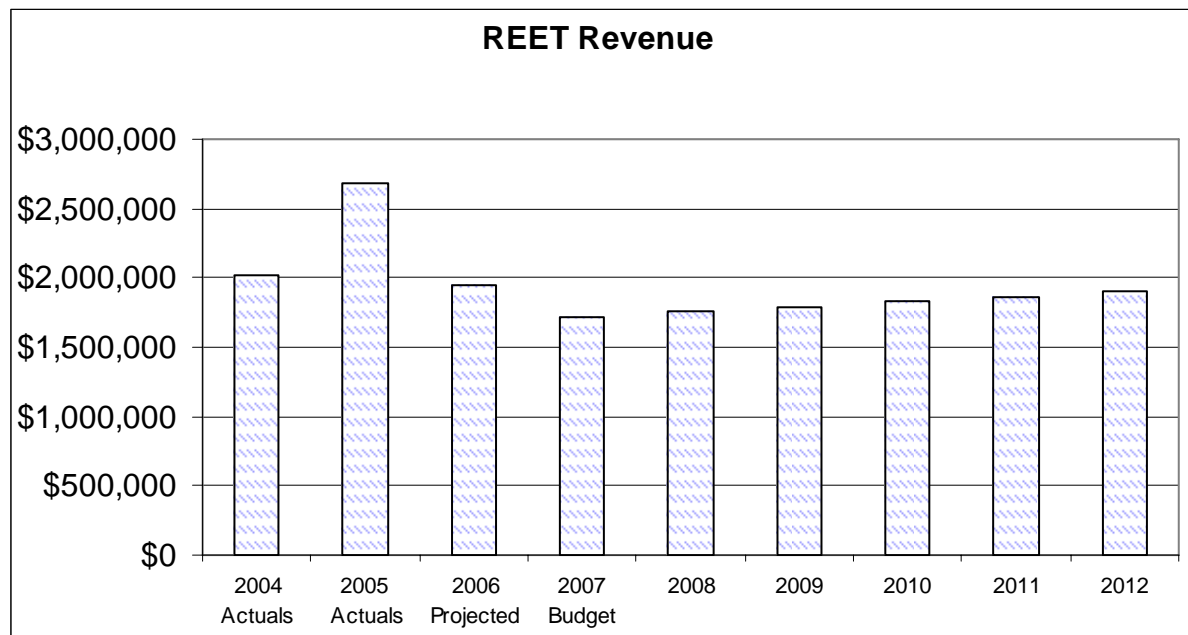

Capital Grants

In 2007, Shoreline is projected to receive \$3,818,025 in grant funding from federal, state and local sources to fund a variety of capital projects. Grants are applied for and received for specific capital improvements. The amount of capital grants received in any given year can vary greatly depending on the number of projects, their cost and the amount of grant funding available.

In the 2007 General Capital Fund budget, the City has included future grant funding totaling \$379,025 to support the open space acquisition and park improvements.

In the Roads Capital Fund, a total of \$3,439,000 has been budgeted from federal, state and local granting agencies. This funding will support a wide range of transportation projects including sidewalk improvements and Aurora Avenue Improvements. For more detail, see the Capital Improvement Plan section of this document.

Expenditures By Object Category

Expenditures by Object Category	2004	2005	2006 Current	2006 Projected	2007 Proposed	2006 Current
	Actuals		Actuals		Budget	Budget
<i>Operations:</i>						
Salaries & Wages	\$ 7,001,787	\$ 7,103,194	\$ 7,821,217	\$ 7,537,225	\$ 8,224,722	\$ 403,505
Personnel Benefits	1,828,894	1,859,480	\$ 2,111,572	\$ 2,088,747	\$ 2,494,435	382,863
Supplies	848,831	875,973	688,119	743,044	763,831	75,712
Other Services & Charges	5,021,744	5,163,179	6,152,218	6,242,396	5,660,628	(491,590)
Intergovernmental Services	8,596,081	8,744,488	9,341,165	9,680,510	9,957,318	616,153
Capital Outlays	140,611	153,234	192,231	250,531	170,500	(21,731)
Debt Service	237,908	343,611	345,450	345,539	350,900	5,450
Contingencies			758,572		598,465	(160,107)
Subtotal Operations	\$ 23,675,856	\$ 24,243,159	\$ 27,410,544	\$ 26,887,992	\$ 28,220,799	\$ 810,255
<i>Other Financing Uses:</i>						
Facilities, Parks and Transportation Capital Imp	\$ 10,269,534	\$ 19,289,020	\$ 53,513,476	\$ 56,409,227	\$ 30,943,898	\$ (22,569,578)
Surface Water Utility *		\$ 3,761,711	\$ 3,049,953	\$ 2,621,064	\$ 5,131,619	\$ 2,081,666
Internal Service Charges	237,817	249,630	277,176	278,914	309,284	32,108
Interfund Transfers	7,239,730	8,996,558	8,607,758	5,555,878	3,600,570	(5,007,188)
Subtotal Other Financing Uses	\$ 17,747,081	\$ 32,296,919	\$ 65,448,363	\$ 64,865,083	\$ 39,985,371	\$ (25,462,992)
Total Expenditures & Uses	\$ 41,422,937	\$ 56,540,078	\$ 92,858,907	\$ 91,753,075	\$ 68,206,170	\$ (24,652,737)

*This category includes salaries and benefits for City staff. In 2007, these total \$ 1,914,921

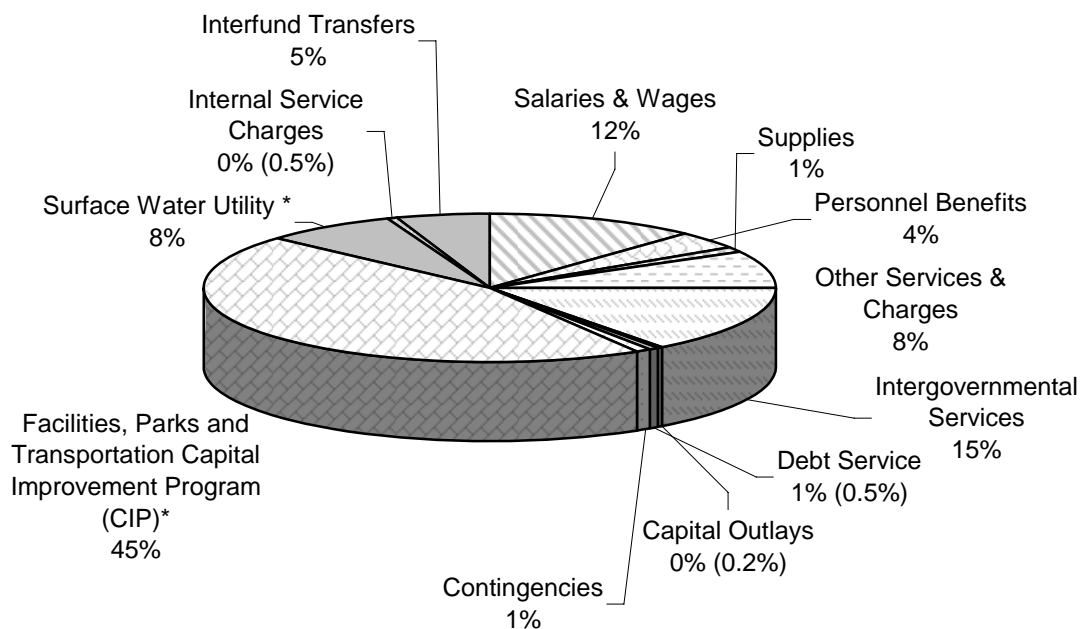

2007 BUDGET DISTRIBUTED BY STRATEGIC OBJECTIVES

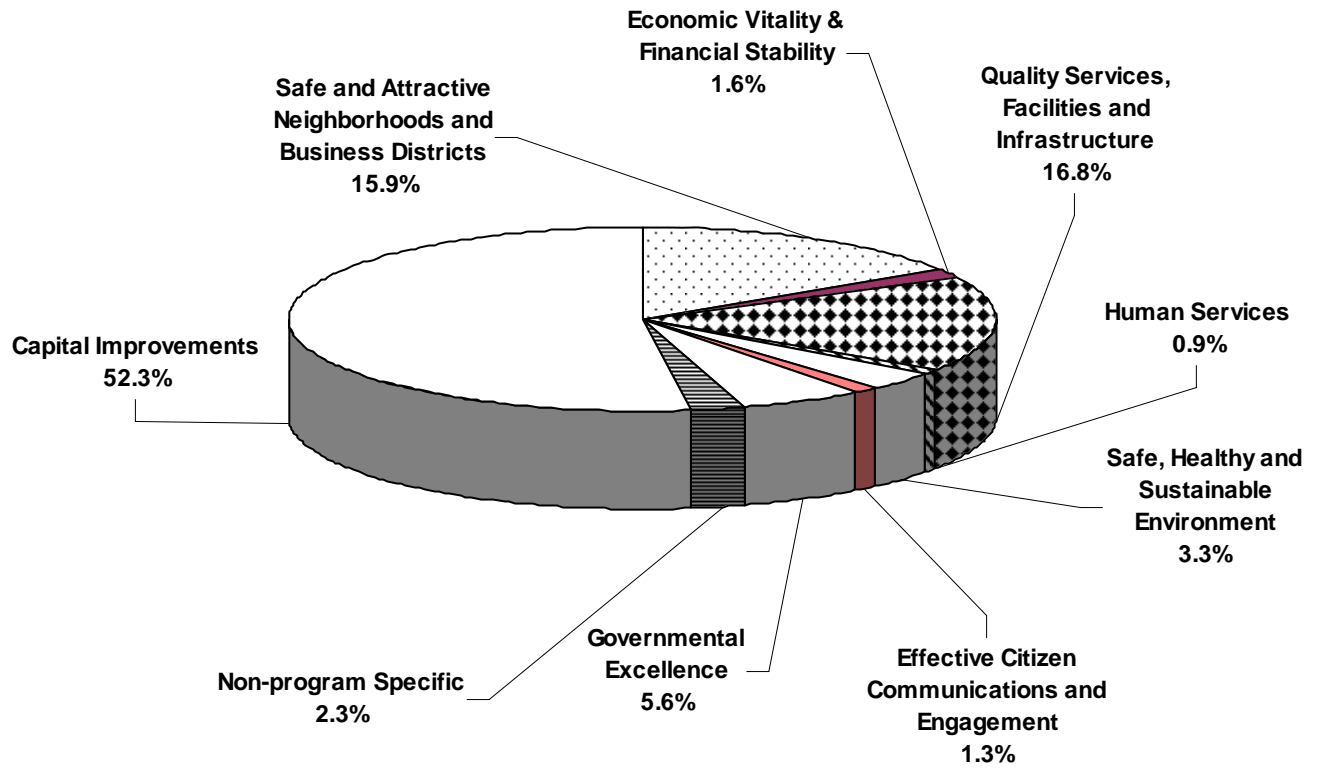

Operating Transfers totaling \$ 2,554,123 not included

2007 Program Budget Summary

Program List	2007 Proposed Budget
Aquatics	792,939
Athletic Field Maintenance & Operations	273,348
Code Enforcement	465,790
General Recreation Programs	779,088
Jail	1,225,217
Neighborhoods	180,648
Parks Administration	406,930
Police Community Storefronts	277,216
Police Investigations Crime Analysis	543,009
Police Patrol	3,887,461
Prosecuting Attorney	168,000
Public Defender	154,209
Police Support Services	1,631,429
Environmental Services	152,028
Right-of-Way Permit and Inspection Program	113,526
Street Crime Investigations	426,649
Street Operation & Pavement Resurfacing Programs	2,865,850
Surface Water Management	1,672,867
Teen Recreation Programs	418,219
Traffic Services & Neighborhood Traffic Safety	458,714
Economic Development: Business Attraction and Retention	257,725
Financial Planning and Accounting Services	765,382
24 Hour Customer Response Team	158,990
Building and Inspections Team	752,182
Geographical Information Systems	185,234
Information Technology Operations and Security Administration	904,387
Legal Services	382,782
Park and Opens Space Maintenance Program	1,059,999
Parks Cultural Services Program	231,445
Permit Services Team	718,932
Planning - Long Range Team	322,219
Planning and Development Operations Support Team	252,624
Police Administration	853,915
Police Traffic Enforcement	700,404
Public Facility & Vehicle Maintenance & Operations	907,389
Public Records & City Council Meeting Management	397,027
Public Works Administration	292,980
Purchasing Services	210,450
Recreation Facility Rental Program	28,763
City Council	174,493
Current Planning Team	540,385
Grant Research & Development	18,672
Information Technology Strategic Plan Implementation	346,474
Organization Strategic Planning and Council Policy Support & Implementation	692,636
Emergency Management Planning	122,715
Human Services: Support for Social Agencies	592,010
Intergovernmental Participation	101,987
Intergovernmental Relations	115,750
School Resource Officer Program	134,899
Sister City Relations	6,000
Communications	282,303
Employee Recruitment, Compensation Administration & Organizational Development	391,553
Sub-Total Program Expenditures	29,795,843
Non-Program Expenditures	
City-Wide:	
Contingencies	598,465
Supplies, Equipment, Election & Liability Insurance	679,491
Code Abatement	100,000
Asset Seizure	23,500
Equipment Replacement	100,000
Unemployment	10,000
Sub-Total Non-Program Expenditures	1,511,456
<i>Operating Transfers (General Fund)</i>	2,554,123
<i>Capital Improvement Program (Less Neighborhood Traffic Safety Program and Road Surface Program)</i>	34,344,748
TOTAL 2007 BUDGET	<u>68,206,170</u>

Ending Fund Balances

The following table and graph illustrate the City's ending fund balances between 2002 and 2005. The fund balances are segregated into three major components: unreserved/undesignated, reserved, and designated.

	2004	Actuals 2005	Actuals	2006 Current Budget	2006 Projected	2007 Proposed
Reserved:						
General Capital Fund	7,980,092	12,100,573	2,103,768	12,232,990	3,472,347	
City Facility -Major Maintenance Fund	-	160,723	170,680	177,152	145,124	
Roads Capital Fund	15,236,389	13,150,365	3,247,990	7,885,027	6,535,098	
Surface Water Capital Fund	3,244,311	-	-	-	-	
Development Services Fund	409,248	-	-	-	-	
Street Fund	618,679	778,568	437,329	795,243	675,243	
Arterial Street Fund	15,535	-	-	-	-	
Surface Water Management Fund	2,986,290	-	-	-	-	
Surface Water Utility Fund		5,548,452	5,440,548	6,363,913	5,754,464	
Subtotal Reserved	30,490,544	31,738,681	11,400,315	27,454,325	16,582,276	
Designated:						
Equipment Replacement Fund	1,168,020	1,251,262	1,514,777	1,470,072	1,685,641	
Vehicle Maintenance & Operations	52,602	47,572	52,134	59,637	59,637	
Unemployment Fund	72,154	69,958	72,604	72,258	72,758	
Code Abatement Fund	38,322	118,916	88,595	68,128	50,628	
Asset Seizure Fund	20,335	21,722	26,058	33,831	33,831	
Public Art Fund	61,040	278,867	324,635	212,240	212,240	
Subtotal Designated	1,412,473	1,788,297	2,078,803	1,916,166	2,114,735	
Unreserved/Undesignated:						
General Fund	10,936,005	9,685,010	5,675,139	7,394,350	6,742,849	
General Reserve	1,970,996	2,160,346	2,178,539	2,282,647	2,341,193	
Subtotal Unreserved/Undesignated	12,907,001	11,845,356	7,853,678	9,676,997	9,084,042	
	44,810,018	45,372,334	21,332,796	39,047,488	27,781,053	

Unreserved/Undesignated Fund Balances

The unreserved/undesignated fund balance is the balance of net financial resources that are available for discretionary appropriations. The 2007 Proposed Budget estimates unreserved/undesignated fund balance of \$9,084,042 at the end of 2007.

Reserved Ending Fund Balances

The second component of ending fund balance is those funds reserved for a specific purpose. These funds are not available for appropriation because they are legally restricted. These reserves primarily represent monies allocated for capital and specific maintenance purposes. The reserved fund balances are estimated to be \$16,582,276 at the end of 2007.

Designated Ending Fund Balances

The third component of ending fund balances, totaling \$2,114,735 in 2007, is those moneys that have been earmarked for specific purposes (equipment replacement, unemployment, etc.). Although designated for specific purposes, there is the ability to appropriate some of these funds for other purposes since the original source of the funds was general revenues from the General Fund.

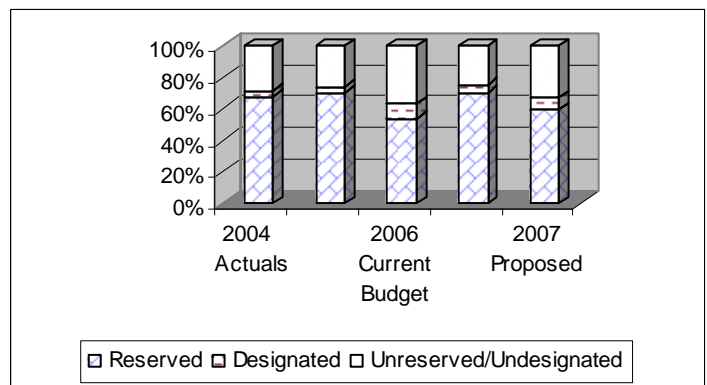

Change in Ending Fund Balance 2007 Proposed Budget Compared to 2006 Projected

	2006 Projected Ending Fund Balance	2007 Proposed Ending Fund Balance	Change in Fund Balance	% Change
General Fund	\$ 7,394,350	\$ 6,742,849	\$ (651,501)	-9%
Street Fund	795,243	675,243	(120,000)	-15%
General Reserve Fund	2,282,647	2,341,193	58,546	3%
Code Abatement Fund	68,128	50,628	(17,500)	-26%
Asset Seizure Fund	33,831	33,831	-	0%
Public Art Fund	212,240	212,240	-	0%
General Capital Fund	12,232,990	3,472,347	(8,760,643)	-72%
City Facility -Major Maintenance Fund	177,152	145,124	(32,028)	-18%
Roads Capital Fund	7,885,027	6,535,098	(1,349,929)	-17%
Surface Water Utility Fund	6,363,913	5,754,464	(609,449)	-10%
Vehicle Operations Fund	59,637	59,637	-	0%
Equipment Replacement Fund	1,470,072	1,685,641	215,569	15%
Unemployment Fund	72,258	72,758	500	1%
	\$ 39,047,488	\$ 27,781,053	\$(11,266,435)	-29%

Explanation of Changes in Fund Balance Greater Than 10%

Street Fund - The 2007 proposed ending fund balance is \$120,000 less than the projected 2006 ending fund balance. Available fund balance is being used to purchase a street sweeper.

Code Abatement – The 2007 proposed ending balance is \$17,500 less than the projected 2006 ending fund balance. Since this fund has accumulated funds they will be used for abatement activities during 2007.

General Capital Fund – The 2007 proposed ending balance is \$8,760,643 less than the projected 2006 ending balance. The majority of the fund balance being appropriated will be used for the Civic Center project. These funds have been set aside in prior years for this project.

City Facility - Major Maintenance Fund – The 2007 proposed ending balance is \$32,028 less than the projected 2006 ending balance. These funds will be used for maintenance projects at the Shoreline Pool.

Roads Capital Fund – The 2007 proposed ending balance is \$1,349,929 less than the projected 2006 ending balance. These funds will be used for various transportation improvements including the Sidewalks – Priority Routes, Dayton Avenue & N. 175th Wall, and Traffic Small Works projects.

Surface Water Utility Fund – The 2007 proposed ending balance is \$609,449 less than the projected 2006 ending balance. These funds will be used for drainage improvements in the Boeing Creek Basin.

Equipment Replacement Fund – The 2007 proposed ending fund balance is \$215,569 more than the projected 2006 ending fund balance. This represents the continued collection of replacement funds to be used to future purchases of equipment.

Municipal Debt Capacity

There are four types of General Obligation Debt that the City is currently authorized to use for financing purposes. They each have statutory limitations and require approval by either the City Council or City voters.

1. General Purpose Voted Debt: As authorized by the Revised Code of Washington (RCW) 39.36.020(2), the public may vote to approve bond issues for general government in an amount not to exceed 2.5% of the value of all taxable property within the City. This requires a 60% vote of the City electorate and must have a voter turnout of at least 40% of the last State general election. The debt would be repaid from an increase to the City's existing property tax levy. An amount up to 2.5% of the City's assessed value can be levied or an estimated \$144,801,967 for 2006.
2. General Purpose Councilmanic Debt: The City Council may approve bond issues without voter approval up to 1.5% of the City's assessed valuation. Prior to the passage of new legislation in 1994, councilmanic debt was available for lease-purchase contracts only (RCW 35.43.200). This statutory authority can be used for any municipal purpose now, including using the entire 1.5% for bonds. Councilmanic debt must be approved by a majority of the City Council and must be repaid from existing operational revenue sources. In 2006, the City Council can levy up to \$86,881,180 or 1.5% of the City's estimated assessed value.

The total General Purpose General Purpose Voted Debt and Councilmanic Debt cannot exceed 2.5% of the City's assessed value.

Under RCW 39.36.030(4), the public may also vote to approve park facilities and utility bond issues, each of which is also limited to no more than 2.5% of the City's assessed valuation.

3. Parks and Open Space Debt: The City is authorized to issue debt and increase the property tax levy for acquiring or developing open space and park facilities. This requires a 60% vote of the City electorate and must have a voter turnout of at least 40% of the last State general election. Debt is repaid from the increased property tax levy. An amount up to 2.5% of the City's estimated assessed value can be levied or \$144,801,967 for 2006.
4. Utility Purpose Debt: The City is authorized to issue debt and increase the property tax levy for utility purposes if a utility is owned and controlled by the City. This requires a 60% vote of the City electorate and must have a voter turnout of at least 40% of the last State general election. Debt would be repaid from the increased property tax levy. An amount up to 2.5% of the City's estimated assessed value can be levied \$144,801,967 for 2006.

CITY OF SHORELINE TOTAL DEBT CAPACITY

Assessed Valuation:		\$ 5,792,078,682			
	General Purpose Debt		Parks & Open Space Debt	Utility Purpose Debt	TOTAL DEBT CAPACITY
Legal Limits	Councilmanic (Non-Voted)	Voted Debt (60% of Voters)	Voted Debt (60% of Voters)	Voted Debt (60% of Voters)	
1.50%	\$ 86,881,180				
2.50%		\$ 144,801,967	\$ 144,801,967	\$ 144,801,967	\$ 434,405,901
Debt Limit:	\$ 86,881,180	\$ 144,801,967	\$ 144,801,967	\$ 144,801,967	\$ 434,405,901
Outstanding Debt:	\$ -	\$ -	\$ -	\$ -	\$ -
Remaining Debt Capacity:	\$ 86,881,180	\$ 144,801,967	\$ 144,801,967	\$ 144,801,967	\$ 434,405,901

Other Long Term Debt

In addition to general obligation debt, the City can utilize a number of other long-term debt instruments, including special assessment bonds and loans from the State of Washington’s Public Works Trust Fund. Special assessment bonds are used to finance public improvements that benefit a specified group of property owners, and are funded from the collection of special assessment payments from property owners. Loans from the Public Works Trust Fund (PWTF) can be used for pre-construction and construction activities for the repair, replacement, rehabilitation, reconstruction, or improvement of eligible public works systems to meet current standards for existing users, and may include reasonable growth as part of the project.

Since incorporation, the City has primarily financed capital improvements on a “pay as you go” basis. During the early years after incorporation, the City was able to build capital reserves for future use as capital needs were being developed. Those reserves are currently being utilized for some of the City’s major capital projects. In the future, if the City intends to meet its capital needs on a timely basis, it will be required to tap into its debt capacity to fund capital projects. This will allow both current and future beneficiaries to share in the cost of the improvements. To date, the only long-term debt the City has is the repayment of two loans from the State’s PWTF program. These loans are being used for drainage improvement projects and will be repaid from surface water fee revenue.

Public Works Trust Fund Loan Debt

The City currently has two PWTF Loans, both of which are being used to fund improvements to the City’s drainage facilities. These loans are the obligation of the Surface Water Fund and are backed by the surface water fees collected from property

owners and are not considered in the City's general obligation debt and are not subject to the limitation of indebtedness calculation.

Ronald Bog Drainage Improvements This public works trust fund loan was approved for a total of \$4,055,500 on 6/18/2001. To date, the City has drawn a total of \$3,852,725. The interest rate of the loan is 0.5%. This project is located in the Ronald Bog Basin whose boundaries are Stone Ave. N., N. 190th St., 15th Ave. N.E., and N.E. 165th. A detention facility will be constructed at Cromwell Park, improvements will be made to the watercourse north of 167th Street along Corliss Place, a stormwater conveyance line will be built along Serpentine Avenue, and improvements will be made to Pump Station # 25. These improvements will reduce the flooding of homes and roadways south of Ronald Bog, at N.E. 175th Street and 10th Ave. N.E., and west of 5th Ave. N.E./Serpentine Place.

3rd Avenue N.W. Drainage Improvements This public works trust fund loan was approved for a total of \$1,959,500 on 6/18/2001. To date, the City has drawn a total of \$1,861,525. The interest rate is 0.5%. This project is located between 3rd and 6th Avenues N.W. from N.W. 176th Street to Richmond Beach Road. This project will construct drainage improvements to alleviate flooding impacts to approximately 20 homes. The existing North Pond facility will be expanded to mitigate for the peak flows from the new conveyance system and prevent increased erosion in downstream Boeing Creek.

Schedule of Long Term Debt

Fund	Fund Name	Type of Debt	Issue Date	Maturity Date	Total Amount Authorized	Interest Rate	Outstanding Debt 12/31/2005	Avg. Annual Debt Service
N/A		General Purpose Voter Approved Bonds	N/A					
N/A		General Purpose Councilmanic Bonds	N/A					
N/A		Parks & Open Space Bonds	N/A					
N/A		Utility Purpose Bonds	N/A					
N/A		Special Assessment Bonds	N/A					
		Public Works Trust Fund Loans						
Fund 103	Surface Water Management Fund	Ronald Bog Drainage Improvements	6/18/2001	7/1/2021	\$ 4,055,500	0.5%	\$ 3,396,185	\$ 222,283
Fund 103	Surface Water Management Fund	3rd Avenue Drainage Improvements	6/18/2001	7/1/2021	\$ 1,959,500	0.5%	\$ 1,722,904	\$ 112,258
		Total Public Works Trust Fund Loans			\$ 6,015,000		\$ 5,119,089	\$ 334,541
		Total Long Term Debt			\$ 6,015,000		\$ 5,119,089	\$ 334,541

City of Shoreline Debt Policies

The Objectives of the City's Debt Management Policy are:

- To limit the use of debt so that debt service payments will be a predictable and manageable part of the operating budget.
- To raise capital at the lowest cost, consistent with the need to borrow. This will be accomplished by:
 - ❑ Keeping a high credit rating (while making attempts to strengthen credit rating).
 - ❑ Maintaining a good reputation in the credit markets by adjusting the capital program for regular entry to the bond market and by managing the annual budget responsibly.
 - ❑ Institute and maintain procedures that ensure full and timely repayment of City obligations.

General Debt Policies

- Before issuing any debt, the City will consider the impacts of such debt on the operating budget, the effect on the City's credit rating, the debt capacity remaining under constitutional and statutory limitations, the most cost-effective term, structure, and type of debt, and the impact on taxpayers.
- Disclosure statements will be used to keep taxpayers and investors informed of the City's financial position. These include printed copies of:
 - ❑ Annual reports
 - ❑ Operating budget and Capital Facilities Plan
 - ❑ Official Statements
- Debt issues will be sold on a competitive basis (except when conditions make a negotiated sale preferable) and awarded to the bidder who produces the lowest true interest cost.
- Debt issues may be sold on a negotiated basis if the issue is unusually large or small, the project is complex, the issue is a refunding, flexibility is desired in the structure, the market is volatile, or other conditions make it in the City's best interest to conduct a negotiated sale.
- Long Term Debt: Long term debt will be used to maintain and develop the municipal infrastructure when the economic life of a fixed asset exceeds five years.
- Revenue bonds will generally be used for projects that are financially self-sustaining.

- General Obligation bonds can be used to finance public works projects that benefit the community and where there are sufficient dedicated revenues to amortize the debt.
- General Obligation pledges can be used to back self-sustaining projects financed through revenue bonds when costs can be reduced and the municipal credit rating is not put in jeopardy by this action.
- The City will continue to rely on a strong local improvement district program for certain local or neighborhood street, water and sewer improvements.
- The City will use interfund borrowing where such borrowing is cost effective to both the borrowing and the lending fund. Such borrowing shall implement Council directed policy in a simplified manner, such as borrowing associated with interim financing for local improvement district projects.



OPERATING BUDGET

DEPARTMENT/FUND OVERVIEW

The following charts provide an illustration of the relationship between the City's departments and funds. Most departments manage programs in the General Fund. Finance, Police, Planning & Development Services and Public Works are also responsible for programs in other funds.

Fund / Revenue	Operating Budget				
	General Fund	Street Fund	General Reserve Fund	Code Abate. Fund	Asset Seizure Fund
Operating Expenditures					
City Council	\$174,494				
City Manager	\$815,352				
City Clerk	\$403,027				
Comm. & Govt. Relations	\$578,700				
Human Services	\$592,010				
City Attorney	\$550,782				
Finance	\$3,810,526				
Human Resources	\$391,553				
Customer Response Team	\$454,259				
Police	\$8,541,937				\$23,500
Criminal Justice	\$1,379,426				
Parks & Recreation	\$3,953,790				
Planning & Dev. Services	\$2,756,866			\$100,000	
Economic Development	\$257,725				
Public Works	\$1,212,411	\$1,891,911			
Operating Expenditures	\$25,872,858	\$1,891,911	\$0	\$100,000	\$23,500
Capital Expenditures	\$0				
Transfers Out	\$2,554,123	\$530,176	\$0	\$0	\$0
Total Expenditures	\$28,426,981	\$2,422,087	\$0	\$100,000	\$23,500

Fund / Revenue	Capital Budget			Enterprise Fund	Internal Service Fund				Total City
	General Capital Fund	Facility Major Maint. Fund	Roads Capital Fund	Surface Water Utility Fund	Public Arts Fund	Equip. Repl. Fund	Vehicle Ops. & Maint. Fund	Unemp. Fund	
Operating Expenditures									
City Council									\$174,494
City Manager									\$815,352
City Clerk									\$403,027
Comm. & Govt. Relations									\$578,700
Human Services									\$592,010
City Attorney									\$550,782
Finance						\$100,000		\$10,000	\$3,920,526
Human Resources									\$391,553
CRT									\$454,259
Police									\$8,565,437
Criminal Justice									\$1,379,426
Parks & Recreation					\$0				\$3,953,790
Planning & Dev. Services									\$2,856,866
Economic Development									\$257,725
Public Works				\$5,522,120			\$139,988		\$8,766,430
Operating Expenditures	\$0	\$0	\$0	\$5,522,120	\$0	\$100,000	\$139,988	\$10,000	\$33,660,377
Capital Expenditures	\$23,657,469	\$110,000	\$7,177,754						\$30,945,223
Transfers Out	\$33,754	\$0	\$55,680	\$426,837	\$0	\$0	\$0	\$0	\$3,600,570
Total Expenditures	\$23,691,223	\$110,000	\$7,233,434	\$5,948,957	\$0	\$100,000	\$139,988	\$10,000	\$68,206,170

City of Shoreline - 2007 FTE Summary

Department												2007
	1997	1998	1999	2000	2001	2002	2003	2004	2005	2006	2007	Changes
City Council	7.00	7.00	7.00	7.00	7.00	7.00	7.00	7.00	7.0	7.0	7.0	0.0
City Manager	9.00	10.00	10.00	9.00	6.00	6.00	6.00	6.00	6.0	6.0	7.0	1.0
City Clerk	3.00	3.00	3.00	3.00	4.00	4.00	4.00	4.00	3.8	3.8	3.8	0.0
Economic Development						1.00	1.00	1.00	1.0	1.0	1.0	0.0
Communications & Inter-Governmental Relations	3.00	3.00	2.00	2.50	3.50	3.50	3.00	3.50	3.5	3.5	3.5	0.0
Health and Human Services	2.00	2.00	2.00	2.00	2.00	2.00	0.00	1.80	1.8	1.8	1.8	0.0
City Attorney	1.00	1.00	1.00	1.00	1.00	1.00	2.50	3.50	3.5	3.0	3.0	0.0
Customer Response Team	0.00	0.00	0.00	0.00	5.00	5.00	5.00	5.00	5.0	5.0	5.0	0.0
Finance / Information Services	12.00	12.00	12.00	14.00	16.63	17.13	17.13	17.33	16.8	17.8	18.1	0.3
Human Resources	2.00	2.00	2.00	2.50	2.50	2.50	3.00	3.00	3.0	3.0	3.0	0.0
Police	0.00	1.00	1.00	1.00	1.00	1.00	1.00	2.00	2.0	2.0	1.0	(1.0)
Planning and Development Services	20.00	24.00	25.00	27.00	28.50	26.00	25.90	25.90	26.9	28.5	28.5	0.0
Parks, Recreation & Cultural Services	12.50	16.50	13.00	17.12	21.65	22.02	24.52	23.30	23.3	25.8	26.8	1.0
Public Works	10.00	15.00	22.00	28.00	27.50	30.00	33.10	35.60	36.1	37.0	37.0	0.0
Total FTE	81.50	96.50	100.00	114.12	126.28	128.15	133.15	138.93	139.7	145.2	146.5	1.3

Explanation of 2007 Changes in FTE

City Manager

The Emergency Management Coordinator (1.0 FTE) position was moved from Police to City Manager during 2006. The Deputy City Manager (1.0 FTE) position was eliminated and a new Management Analyst (1.0 FTE) position was created during 2006.

Finance

The FTE allocation has been increased for the Finance Technician in Purchasing (from 0.62 FTE to 0.75 FTE) and the Finance Technician in Accounting Services (from 0.50 FTE to 0.625 FTE) for a total change of 0.25 FTE in order to keep up with current workload. Demands in Financial Operations have increased for the current Finance Technician that does accounts payable and payroll functions. Since 2003 the number transaction that this position completes has increased by 16%. The number of purchasing transaction and contracts has increased as additional projects have come on-line.

Police

The Emergency Management Coordinator (1.0 FTE) position was moved from Police to City Manager

Planning & Development Services

A new Development Review Engineer (1.0 FTE) was added in 2006 to meet increased demand and is funded by additional development review revenue.

Parks, Recreation & Cultural Services

A new Athletic Field Maintenance - Park Maintenance Worker II (1.0 FTE) was added for 2007 to perform all daily athletic field maintenance at nine park sites (field watering, dragging and lining) during each sport season and the installation of additional infield soils on baseball/softball fields. This position replaces part of the Parks Landscape and Maintenance Service contract currently in place.

2007 City of Shoreline Budgeted Positions and FTE's

Department	Job Title	Position Count	FTE Count
City Council	Mayor	1	1.0
City Council	Deputy Mayor	1	1.0
City Council	Councilmember	5	5.0
	<i>Department Total</i>	7	7.0
City Manager	City Manager	1	1.0
City Manager	Assistant City Manager	1	1.0
City Manager	Management Analyst	2	2.0
City Manager	Emergency Management Coordinator	1	1.0
City Manager	Executive Asst. to the City Manager	1	1.0
City Manager	Administrative Assistant III	1	1.0
	<i>Department Total</i>	7	7.0
City Clerk	City Clerk	1	1.0
City Clerk	Deputy City Clerk	1	1.0
City Clerk	Records & Information Manager	1	0.8
City Clerk	Administrative Assistant II	1	1.0
	<i>Department Total</i>	4	3.8
Communications & Intergovt. Relations	Communications & Intergovt. Relations Director	1	1.0
Communications & Intergovt. Relations	Neighborhoods Coordinator	1	1.0
Communications & Intergovt. Relations	Communications Specialist	1	1.0
Communications & Intergovt. Relations	Administrative Assistant II	1	0.5
	<i>Department Total</i>	4	3.5
Human Services	Human Services Manager	1	1.0
Human Services	Grants Specialist	0	0.3
Human Services	Human Services Planner (Planner II)	1	0.5
	<i>Department Total</i>	2	1.8
City Attorney	City Attorney	1	1.0
City Attorney	Assistant City Attorney	1	1.0
City Attorney	Administrative Assistant II	1	1.0
	<i>Department Total</i>	3	3.0
Finance & Information Services	Finance Director	1	1.0
Finance & Information Services	Finance Manager	1	1.0
Finance & Information Services	Purchasing Officer	1	1.0
Finance & Information Services	Finance Technician	2	1.4
Finance & Information Services	AP/Payroll Technician	1	1.0
Finance & Information Services	Payroll Officer	1	1.0
Finance & Information Services	Senior Accountant	1	1.0
Finance & Information Services	Budget Analyst	2	2.0
Finance & Information Services	Grants Specialist	1	0.7
Finance & Information Services	Administrative Assistant III	1	1.0
Finance & Information Services	Information Systems Manager	1	1.0
Finance & Information Services	Database Administrator	1	1.0

2007 City of Shoreline Budgeted Positions and FTE's

Department	Job Title	Position Count	FTE Count
Finance & Information Services	GIS Specialist	1	1.0
Finance & Information Services	Network Administrator	1	1.0
Finance & Information Services	Web Developer	1	1.0
Finance & Information Services	Computer/Network Specialist	2	2.0
	<i>Department Total</i>	19	18.1
Human Resources	Human Resource Director	1	1.0
Human Resources	Human Resources Analyst	1	1.0
Human Resources	Administrative Assistant III	1	1.0
	<i>Department Total</i>	3	3.0
Customer Response Team	Administrative Assistant II	1	1.0
Customer Response Team	Customer Response Team Supervisor	1	1.0
Customer Response Team	Lead CRT Representative	1	1.0
Customer Response Team	CRT Representative	2	2.0
	<i>Department Total</i>	5	5.0
Police	Administrative Assistant II	1	1.0
	<i>Department Total</i>	1	1.0
Parks & Recreation	Parks Director	1	1.0
Parks & Recreation	Recreation Superintendent	1	1.0
Parks & Recreation	Recreation Coordinator	2	1.5
Parks & Recreation	Recreation Coordinator II	2	2.0
Parks & Recreation	Administrative Assistant I	1	0.5
Parks & Recreation	Administrative Assistant II	2	2.0
Parks & Recreation	Administrative Assistant III	1	1.0
Parks & Recreation	Recreation Assistant II	3	2.4
Parks & Recreation	Recreation Assistant III	1	1.0
Parks & Recreation	Parks Superintendent	1	1.0
Parks & Recreation	Parks Maintenance Worker II	4	4.0
Parks & Recreation	Parks Maintenance Worker I	2	2.0
Parks & Recreation	Parks Project Coordinator	1	1.0
Parks & Recreation	Teen Program Supervisor	1	0.5
Parks & Recreation	Teen Program Assistant	3	2.7
Parks & Recreation	Senior Lifeguard	3	2.4
Parks & Recreation	Lifeguard 2	1	0.9
	<i>Department Total</i>	30	26.8
Planning & Development Services	Planning & Development Services Director	1	1.0
Planning & Development Services	Assistant Director, PADS	1	1.0
Planning & Development Services	Management Analyst	1	1.0
Planning & Development Services	Permit Services Manager	1	1.0
Planning & Development Services	Planner III (Aurora Corridor Project)	1	1.0
Planning & Development Services	Planner III	2	2.0
Planning & Development Services	Planner II	4	4.0
Planning & Development Services	Planner I	2	2.0

2007 City of Shoreline Budgeted Positions and FTE's

Department	Job Title	Position Count	FTE Count
Planning & Development Services	Building Official	1	1.0
Planning & Development Services	Plans Examiner III	2	2.0
Planning & Development Services	Plans Examiner II	1	1.0
Planning & Development Services	Development Review Engineer	2	2.0
Planning & Development Services	Combination Inspector	2	2.0
Planning & Development Services	Code Enforcement Officer	1	1.0
Planning & Development Services	Technical Assistant	4	3.5
Planning & Development Services	Administrative Assistant II	2	2.0
Planning & Development Services	Administrative Assistant III	1	1.0
	<i>Department Total</i>	29	28.5
Economic Development	Economic Development Program Manager	1	1.0
		1	1.0
Public Works	Public Works Director	1	1.0
Public Works	Public Works Service Manager	1	1.0
Public Works	Management Analyst	1	1.0
Public Works	City Engineer	1	1.0
Public Works	Aurora Corridor Project Manager	1	1.0
Public Works	Capital Projects Manager I	1	1.0
Public Works	Capital Projects Manager II	4	4.0
Public Works	Capital Project Technician	1	1.0
Public Works	Public Works Operations Manager	1	1.0
Public Works	Public Works Maintenance Supervisor	1	1.0
Public Works	Public Works Senior Maintenance Worker	1	1.0
Public Works	Public Works Maintenance Worker II	6	6.0
Public Works	Public Works Maintenance Worker I	1	1.0
Public Works	Surface Water & Env. Svcs. Manager	1	1.0
Public Works	Facility Maintenance Supervisor	1	1.0
Public Works	Facilities Maint. Worker II	1	1.0
Public Works	Administrative Assistant II	2	2.0
Public Works	Administrative Assistant III	1	1.0
Public Works	Engineering Technician (Traffic)	1	1.0
Public Works	Engineering Technician (Surface Water)	1	1.0
Public Works	Administrative Assistant II (Aurora/Interurban)	1	1.0
Public Works	Traffic Engineer	1	1.0
Public Works	Associate Traffic Engineer	1	1.0
Public Works	Engineering Technician	1	1.0
Public Works	Environmental Educator	1	1.0
Public Works	Surface Water Quality Specialist	1	1.0
Public Works	Right-of-Way Inspector	2	2.0
	<i>Department Total</i>	37	37.0
	Total City Personnel	150	146.5



This Page Has Been Intentionally Left Blank



City Council



City Council 2007 Budget

Mission Statement

“The City Council is a representative body, comprised of seven citizens elected by the community to provide leadership to the organization and community. The Council seeks to maintain a healthy, vibrant and attractive place to live and work by adopting policies that create and support the values and vision of our community.”

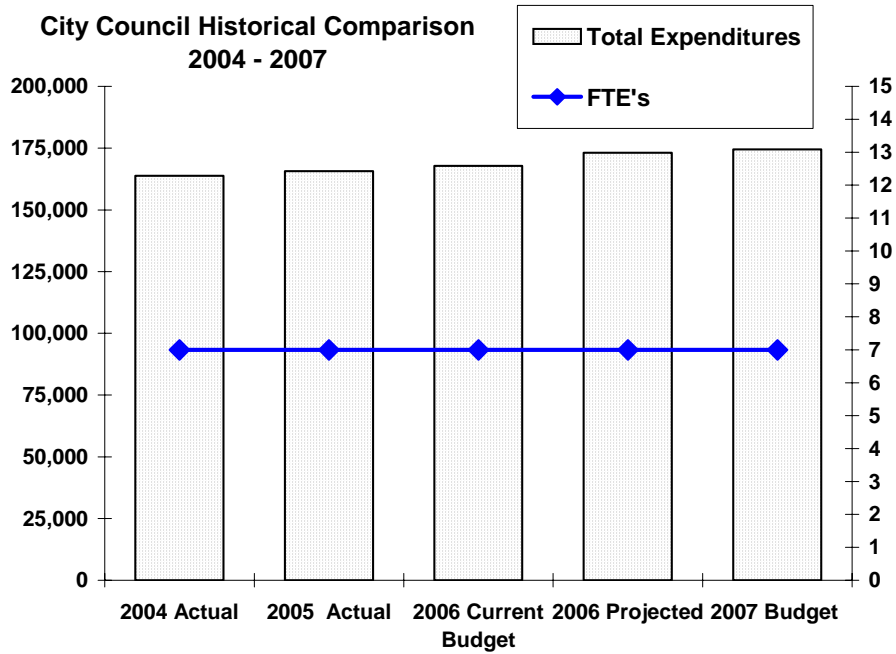

2007 City Council as a Share of the General Fund

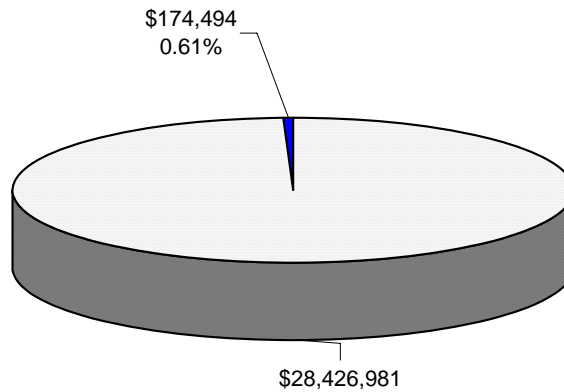



City Council 2007 Budget

2006 Key Accomplishments in Support of the City's Strategic Objectives:

Quality Services, Facilities and Infrastructure

- Restored and reprioritized funding for the City's street overlay and slurry seal program.
- Completed improvements to Shoreline A and B soccer fields and authorized the purchase of three acres of the South Woods property.
- Unanimously supported the Parks and Open Space Bond Levy, which passed with a 70% margin.
- Authorized the land purchase for the construction of a new Civic Center.
- Converted over 1,000 streetlights from private to City responsibility.
- Completed Phase I of the Aurora Avenue North Improvement project from 145th to 165th Street to include the two bridges for the Interurban Trail.
- Reviewed, revised, and adopted the 2007-2012 Capital Improvement Plan to address capital improvements such as open space acquisitions, the annual road surface maintenance program, soccer field improvements, sidewalk construction, and the Neighborhood Parks Repair and Replacement program.

Safe and Attractive Neighborhoods and Business Districts

- Approved a contract enhancing Animal Control Services with King County.
- Unanimously adopted a modified development code with regard to cottage housing.
- Adopted an amended Critical Areas Ordinance.
- Adopted an ordinance revising arterial speed limits throughout the city providing both safer and more efficient travel for pedestrians and motorists.
- Completed the North City Business District improvement project and provided directory marketing the District to area residents.

Economic Vitality and Financial Stability

- Reviewed and adopted the 2006-2011 Economic Development Strategic Plan.
- Completed the Aurora Corridor Improvement Project Phase I and Interurban Trail bridges spurring new economic development including a new insurance office and retail project, a new credit union building, a four-story storage structure, a 35,000-square-foot office and retail building with 65 condominiums facing the Interurban Trail, a new restaurant, and new financial institution.
- Adopted a Business Registration Program to better assist the City and business community in economic development planning and resource allocation.



City Council 2007 Budget

Safe, Healthy, and Sustainable environment

- Adopted the US Mayor's Climate Protection Agreement.

Effective Citizen Communication and Engagement

- Hosted the eighth annual volunteer recognition breakfast to recognize the accomplishments of volunteers in service to the City of Shoreline.
- Appointed two new Library Board and four new Planning Commissioner members.
- Modified the Council Rules of Procedure to include community presentations.
- Televised several Planning Commission meetings regarding the Hazardous Trees Ordinance.
- Conducted two community-wide workshops to seek input on the proposed Council 2007-2008 goals.

2007 Key Objectives in Support of the City's Strategic Objectives:

Governmental Excellence

- Councilmembers actively participate in Suburban Cities Association, Puget Sound Regional Council, and Water Resource Inventory Area 8.



City Council 2007 Budget

2007 – 2008 CITY COUNCIL WORKPLAN

- Goal No. 1 Complete the projects approved in the 2006 Parks Bond.**
- Goal No. 2 Implement the Economic Development Strategic plan.**
- Goal No. 3 Implement an affordable civic center/city hall project.**
- Goal No. 4 Complete the Aurora improvements from 165th to 205th Streets including but not limited to sidewalks, drainage, and transit.**
- Goal No. 5 Develop a comprehensive housing strategy.**
- Goal No. 6 Create an “environmentally sustainable community.”**
- Goal No. 7 Provide safe and affordable transportation options to support land use plans including walking, bicycling, transit, and vehicular options.**
- Goal No. 8 Develop a Fircrest master plan in partnership with the state.**
- Goal No. 9 Increase emergency preparedness training and education.**
- Goal No. 10 Increase opportunities for all residents, including our youth, to get more involved in neighborhood safety and improvement programs.**



City Council 2007 Budget

City Council 2004 - 2007 Budget Comparison By Program							
Program Budget	2004 Actual	2005 Actual	2006 Current Budget	2006 Projected	2007 Budget	2006 Current Budget versus 2007 Budget	Percentage Change
City Council	\$163,784	\$165,668	\$167,738	\$173,123	\$174,494	\$6,756	4.0%
Total Expenditures	\$163,784	\$165,668	\$167,738	\$173,123	\$174,494	\$6,756	4.03%
Program Revenue							
City Council	\$0	\$0	\$0	\$0	\$0	\$0	0.00%
General Fund Subsidy	\$163,784	\$165,668	\$167,738	\$173,123	\$174,494	\$6,756	4.03%
Total Resources	\$163,784	\$165,668	\$167,738	\$173,123	\$174,494	\$6,756	4.03%
Department Statistics							
FTE's	7	7	7	7	7	0	0

City Council 2004 - 2007 Budget Comparison By Object							
Object Category	2004 Actual	2005 Actual	2006 Current Budget	2006 Projected	2007 Budget	2006 Current Budget versus 2007 Budget	Percentage Change
Salaries	\$61,250	\$60,950	\$60,900	\$60,900	\$60,900	\$0	0.0%
Personnel Benefits	\$51,661	\$52,604	\$55,538	\$55,537	\$59,794	\$4,256	7.7%
Supplies	\$864	\$673	\$1,000	\$1,075	\$2,000	\$1,000	100.0%
Other Services & Charges	\$50,009	\$51,441	\$50,300	\$55,611	\$51,800	\$1,500	3.0%
Capital Outlays	\$0	\$0	\$0	\$0	\$0	\$0	0.0%
Total Expenditures	\$163,784	\$165,668	\$167,738	\$173,123	\$174,494	\$6,756	4.03%
Revenue							
Other Revenue	\$0	\$0	\$0	\$0	\$0	\$0	0.00%
General Fund Subsidy	\$163,784	\$165,668	\$167,738	\$173,123	\$174,494	\$6,756	4.03%
Total Resources	\$163,784	\$165,668	\$167,738	\$173,123	\$174,494	\$6,756	4.03%
Department Statistics							
FTE's	7	7	7	7	7	0	0
% of General Fund	0.68%	0.56%	0.57%	0.59%	0.61%	0.04%	7.58%

CITY COUNCIL

PROGRAM PURPOSE:

The City Council is a representative body, comprised of seven citizens elected by the community to provide leadership to the organization and community. The Council seeks to maintain a healthy, vibrant and attractive place to live and work by adopting policies that create and support the values and vision of our community.

STRATEGIC OBJECTIVES:

Governmental Excellence

Measurement: EFFECTIVENESS	2004	2005	2006	2007/Target
Percentage of residents that are satisfied with the overall quality of leadership provided by the City's elected officials	47%	47%	N/A	
Percentage of residents who believe the City is moving in the right direction	58%	58%	N/A	

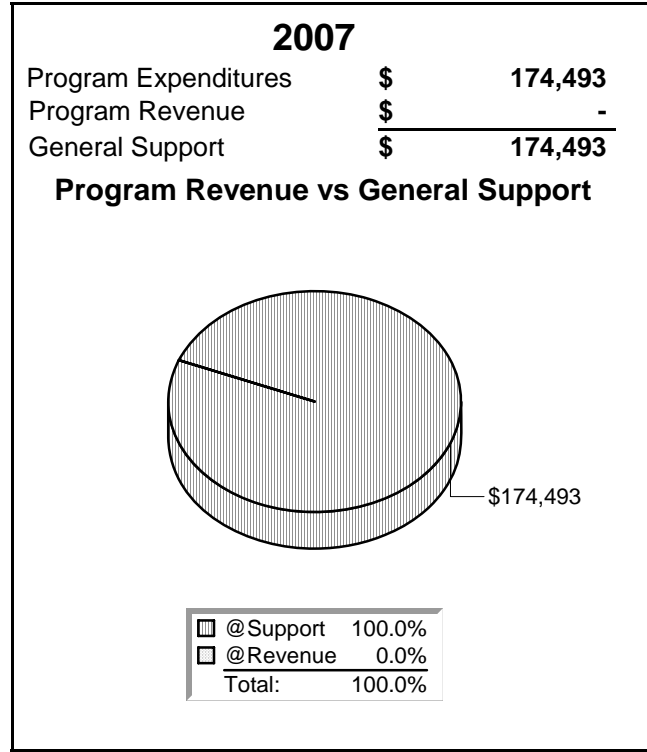
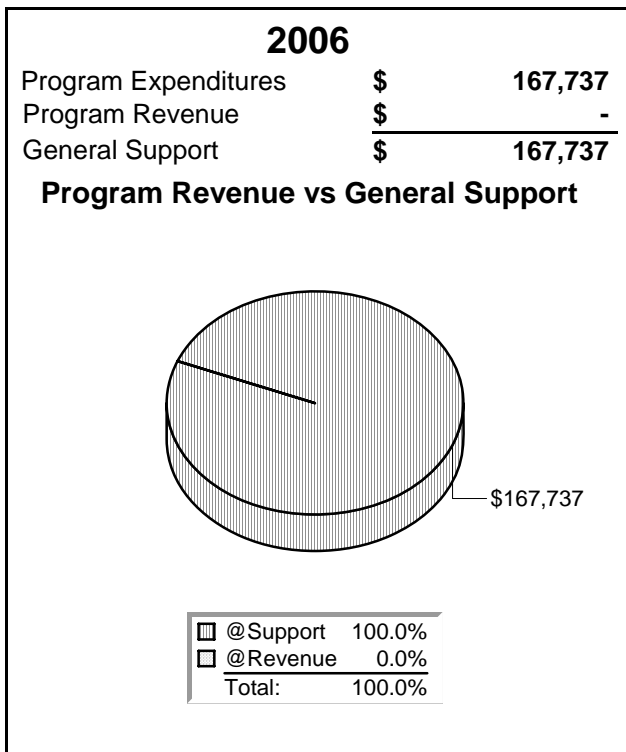



City Manager's Office

Mission Statement

“Implement Council goals and direction, provide organizational leadership, and ensure the delivery of efficient and effective public services.”

Department Programs

Organizational Strategic Planning and Council Policy Support

6.0 FTE

Emergency Management Planning

1.0 FTE
(Formerly in Police)

2007 City Manager as a Share of the General Fund

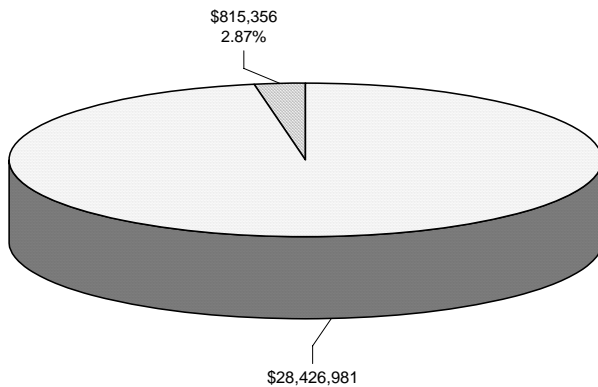

City Manager Historical Comparison

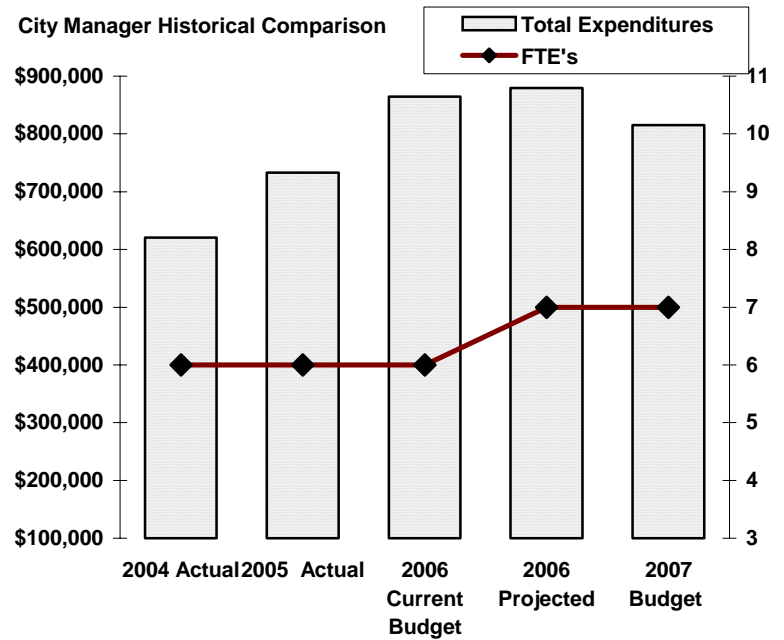



City Manager 2007 Budget

2006 Key Department Accomplishments in Support of the City's Strategic Objectives:

Quality Services, Facilities and Infrastructure

- Negotiated the successful purchase of property for a new City Hall/Civic Center facility.
- Completed the Aurora Corridor/Interurban Bridge Improvement Project from 145th to 165th Street.
- Successfully negotiated the purchase of three acres of the South Woods property from the Shoreline School District.

Governmental Excellence

- Participated in a 15 city Puget Sound Consortium for performance measurement to benchmark and improve services.
- Worked with other municipalities to resolve issues related to regional jail services and expanded the use of Yakima County Jail as a lower cost jail provider.
- Continued work on an action improvement plan in response to the 2005 employee satisfaction survey including advanced training in communications and supervisory skills; supporting a salary survey of a third of job classifications; and supporting improvements to the City's recognition program.
- Developed the 2007-2009 Information Technology Strategic Plan.

Effective Citizen Communication and Engagement

- Processed and responded to over 400 citizen letters and/or emails on behalf of the Council and City Manager's Office.
- Implemented a comprehensive community education program that addresses all potential hazards and threats and promotes emergency preparedness - successfully awarded a \$24,000 grant
- Continued to support, promote and fund the Community Emergency Response Team (CERT) sponsored by the Fire Department
- Developed and presented the "Ready Neighborhood" Program and the "Pass-It-On" Program and hosted Storm Spotter classes
- Completed the City's third bi-annual citizen survey providing critical feedback to service delivery quality.



City Manager 2007 Budget

Safe and Attractive Neighborhoods and Business Districts

- Improved traffic enforcement and safety by significantly increasing the traffic enforcement division and doubling the number of traffic citations issued in the first six months of 2006 compared to 2005.
- Completed the North City Business District improvement project.
- Ensured City's compliance with the federally mandated National Incident Management System (NIMS) by updating the Emergency Operations Plan and training staff on the Incident Command System (ICS)
- Facilitated the siting and opening of an American Red Cross Disaster Relief Supply Center in the city
- Increased the City's capacity to respond to severe weather by coming into compliance with the National Weather Services Storm Ready Program
- Ensured that primary and secondary Emergency Operations Centers are operationally ready
- Conducted a table top exercise and full scale exercise with all emergency responders and key City staff
- Continued the implementation and tracking of the Hazard Mitigation Plan
- Using federal grants, purchased equipment such as 800 megahertz radios and satellite phones and provided a security upgrade for the Police Department

Economic Vitality and Financial Stability

- Will end 2006 with a projected \$ 9.68 million of General Fund and General Reserve ending fund balance, approximately equal to 34% of the General Fund annual revenues.
- Partnered with gas, electricity, water, telecommunication, and waste water service providers for the funding and construction of the Aurora Corridor utility improvements.



City Manager 2007 Budget

2007 Key Department Objectives in Support of the City's Strategic Objectives:

Safe, Healthy, and Sustainable Environment

- Implement the Mayor's Climate Protection Agreement

Quality Services, Facilities and Infrastructure

- Continue implementation of a city-wide performance measurement system.
- Complete design and public process of the Civic Center/City Hall.
- Develop customer service guidelines and a city-wide training program.
- Develop "community report card".
- Complete the environmental review, and 30% planning document for the Aurora Improvements project, 165th to 205th Street.
- Complete the purchase of the South Woods, SPU, and Kruckeberg Botanic Gardens properties.

Economic Vitality and Financial Stability

- Provide leadership to meet the continued design and funding goals for Phase II of the Aurora Corridor Project.
- Implement the long term financial plan to address operational and capital prioritization of unfunded needs.
- Negotiate acquisition of the SPU water system.

Governmental Excellence

- Work with departments to create departmental/divisional level report cards.
- Create work plans for 2007-2008 Council goals with specific emphasis on Goals 5, 6, 8, and 10.
- Continue to develop the organization for continuous improvement in productivity and customer service
- Conduct the 2007 employee satisfaction survey and action plan.
- Recruit additional Employee Emergency Response Team (EERT) members, provide refresher training and conduct citywide evacuation drills
- Develop the City's Continuity of Government Planning and a Recovery Plan



City Manager 2007 Budget

Safe and Attractive Neighborhoods and Business Districts

- Continue to build partnerships with business organizations such as the Chamber of Commerce, Forward Shoreline, and the North City Business District.
- Implement a “Business Ready” Program to educate local businesses in preparing for emergencies
- Conduct table top and field earthquake preparedness drill
- Remain involved in county-wide planning with the development of the Regional Disaster Plan with an emphasis on pandemic flu and mass evacuation planning
- Increase the capabilities of the City’s ability to open a shelter by installing a generator at Spartan Recreation Center - successfully awarded a \$54,531 grant
- Install emergency generator Shelter
- Provide federally mandated training for staff
- Implement priority elements of the Hazard Mitigation Plan

Effective Citizen Communication and Engagement

- Develop and implement a comprehensive community education campaign by empowering citizens to become self-sufficient for a 72-hour minimum
- Conduct quarterly community-wide emergency training in partnership with the Fire Department
- Prepare an emergency preparedness mailing for an entire issue of Currents
- Implement the retail outreach program
- Provide information and training on home and business retrofits
- Complete vision and goals update



City Manager 2007 Budget

City Manager 2004 - 2007 Budget Comparison By Program							
Program Expenditures	2004 Actual	2005 Actual	2006 Current Budget	2006 Projected	2007 Budget	2006 Current Budget versus 2007 Budget	Percentage Change
Organization Strategic Planning & Council Policy	\$620,438	\$733,324	\$733,399	\$669,355	\$692,641	-\$40,758	-5.56%
Emergency Mangement Planning *			\$130,961	\$210,112	\$122,715	-\$8,246	-6.30%
Total Expenditures	\$620,438	\$733,324	\$864,360	\$879,467	\$815,356	-\$49,004	-5.67%
Program Revenue							
Emergency Management Grants *				\$24,123	\$0	\$0	0.00%
General Fund Subsidy	\$620,438	\$733,324	\$864,360	\$855,344	\$815,356	-\$49,004	-5.67%
Total Resources	\$620,438	\$733,324	\$864,360	\$879,467	\$815,356	-\$49,004	-5.67%
Department Statistics							

* Prior to 2007 Emergency Management Planning was part of Police Budget

City Manager 2004 - 2007 Budget Comparison By Object							
Object Category	2004 Actual	2005 Actual	2006 Current Budget	2006 Projected	2007 Budget	2006 Current Budget versus 2007 Budget	Percentage Change
Salaries	\$463,357	\$565,286	\$576,889	\$553,563	\$544,490	-\$32,399	-5.62%
Personnel Benefits	\$102,857	\$111,056	\$135,244	\$136,363	\$143,748	\$8,504	6.29%
Supplies	\$7,446	\$10,362	\$8,500	\$21,744	\$8,500	\$0	0.00%
Other Services & Charges	\$46,778	\$46,619	\$126,256	\$86,988	\$98,786	-\$27,470	-21.76%
Intergovernmental Services	\$0	\$0	\$17,469	\$24,275	\$19,828	\$2,359	0.00%
Capital Outlays	\$0	\$0	\$0	\$56,531	\$0	\$0	0.00%
Interfund Payments for Service	\$0	\$1	\$2	\$3	\$4	\$2	0.00%
Total Expenditures	\$620,438	\$733,324	\$864,360	\$879,467	\$815,356	-\$49,004	-5.67%
Revenue							
Emergency Management Grants *			\$130,961	\$210,112	\$122,715	-\$8,246	0.00%
General Fund Subsidy	\$620,438	\$733,324	\$733,399	\$669,355	\$692,641	-\$40,758	-5.56%
Total Resources	\$620,438	\$733,324	\$864,360	\$879,467	\$815,356	-\$49,004	-5.67%
Department Statistics							
FTE's	6	6	6	7	7	1	0
% of General Fund	2.57%	2.49%	2.94%	3.00%	2.87%	-0.07%	-2.45%

2007 Key Department Highlights

- The Emergency Management Planning program was shifted to the City Manager's Office for oversight in 2006. This program had previously been included in the Police Department. The 2007 Budget for the City Manager's Office includes the Emergency Management Planning program.
- In 2006 the City Manager's Office eliminated the Deputy City Manager position and added a second Management Analyst position. The Management Analyst position is at a lower pay classification than the Deputy City Manager position resulting in reduced salary costs for 2007.
- The 2007 professional services budget within the City Manager's Office was reduced by \$7,000 when compared to previous years. These monies served as a contingency for special projects that needed to be completed throughout the year.

ORGANIZATION STRATEGIC PLANNING AND COUNCIL POLICY SUPPORT & IMPLEMENTATION

PROGRAM PURPOSE:

The City Manager's Office is accountable to the City Council for operational and financial results and organizational leadership.

STRATEGIC OBJECTIVES:

Governmental Excellence

Measurement: EFFECTIVENESS	2004	2005	2006	2007/Target
Percent of residents who are very satisfied/satisfied with the overall quality of services		69%	N/A	69%
Percent of residents who contacted City staff and who believe staff were courteous/polite		92%	N/A	92%
Percentage of citizens that rate the value of services received for their city taxes paid as Average, Good or Excellent.	75%	75%		80%
Percentage of Employees who Have a Clear Understanding of City's Mission, Goals, and Organizational Values	90%	94%	N/A	95%
Percentage of employees who rate the City of Shoreline as "one of the best" or "above average" as an organization to work for	64%	73%	N/A	75%
Percentage of residents who are neutral, satisfied or very satisfied with the effectiveness of the City Manager and appointed staff	49%	49%	N/A	50%

Measurement: EFFICIENCY	2004	2005	2006	2007/Target
City operating reserves as a percentage of operating revenues	49.4%	36.7%	35.5%	32.5%
Number of regular City employees per 1,000 population	2.6	2.6	2.6	2.6
Operating expenditures per capita (constant \$)	\$232	\$233	\$245	\$250
Operating expenditures per capita (real dollars)	\$454	\$468	\$499	\$525
Operating revenue per capita (constant \$)	\$237.90	\$239.2	\$245.5	\$246.8
Program budget as a percent of the City's operating budget	2.5%	2.5%	2.5%	3.2%
Support service costs as a percentage of the City's general fund	15.2%	13.7%	15%	
Total process time to respond to citizen letters or emails (working days).		15		

ORGANIZATION STRATEGIC PLANNING AND COUNCIL POLICY SUPPORT & IMPLEMENTATION

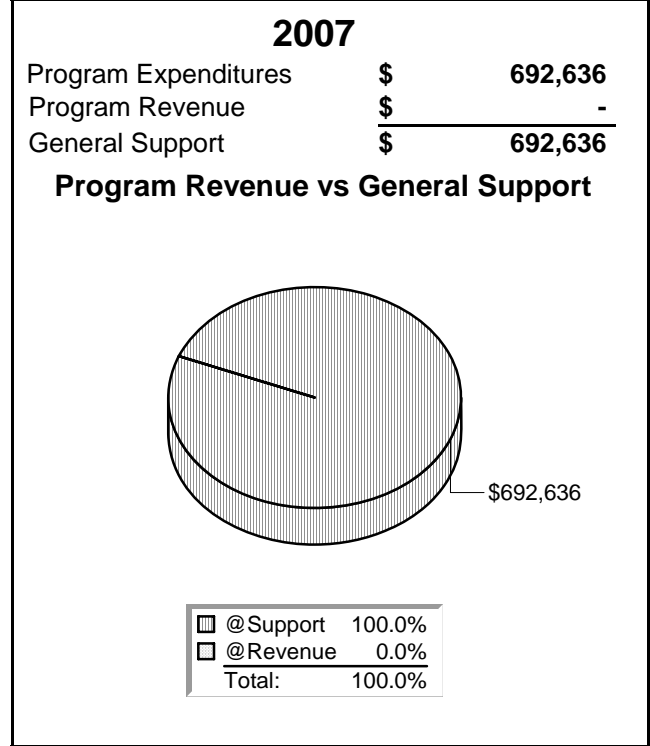
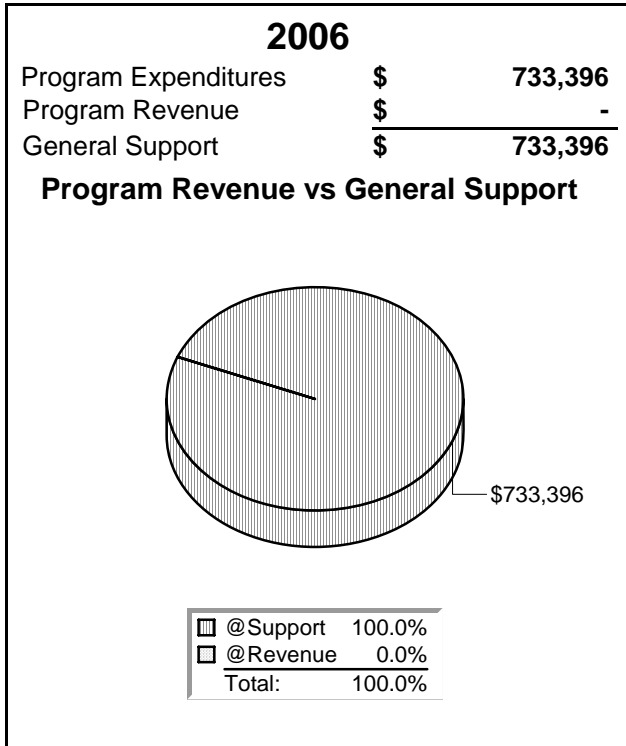

EMERGENCY MANAGEMENT PLANNING

PROGRAM PURPOSE:

The purpose of emergency preparedness in the City of Shoreline is to provide an emergency management organization and resources to minimize the loss of life; protect property and natural resources; and restore the proper operations of the City in the event of a major disaster.

STRATEGIC OBJECTIVES:

Safe and Attractive Neighborhoods and Business Districts

Measurement: EFFECTIVENESS	2004	2005	2006	2007/Target
Amount of Grant funds awarded	\$99,197	\$18,905	\$80,654	\$30,000
Percent of Hazard Mitigation Plan completed	N/A	N/A	N/A	
Percent of staff trained in emergency planning and preparedness	N/A	N/A	N/A	

Measurement: WORKLOAD	2004	2005	2006	2007/Target
Number of Community Emergency Response volunteers trained	31	50		
Number of presentations and training provided to the community (block watches, neighborhoods, businesses, faith groups, civic				
Number of table tops, functional and full scale exercises conducted				

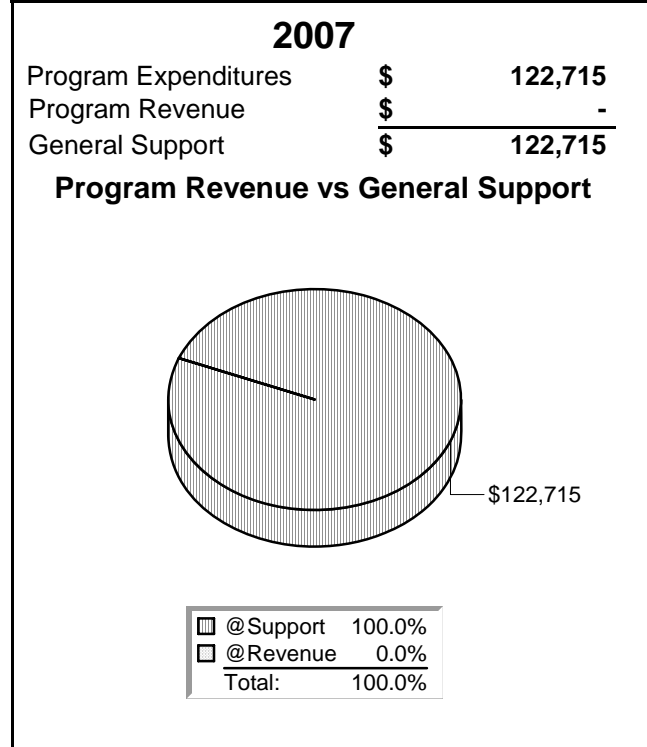
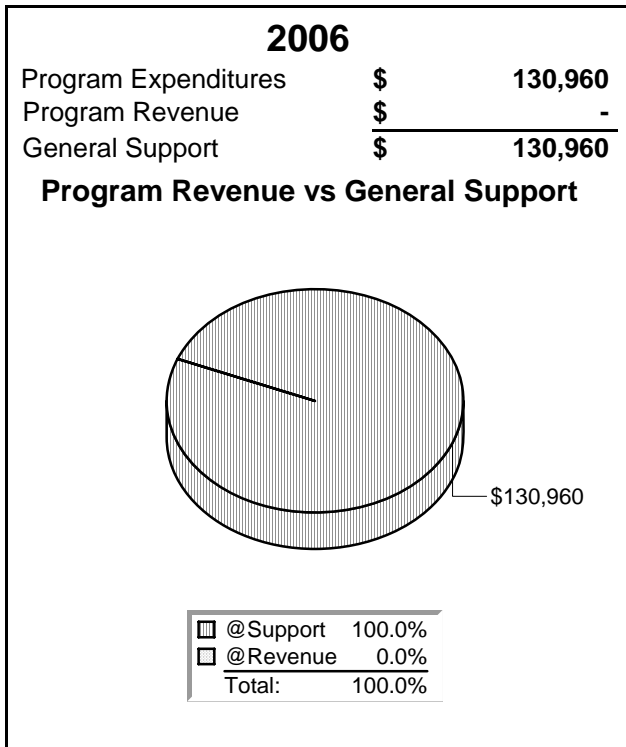



This Page Has Been Intentionally Left Blank



City Clerk



City Clerk 2007 Budget

Mission Statement

The City Clerk facilitates the effective functioning of the democratic process in the City of Shoreline's governance. We do this by: overseeing the efficient and legal conduct of City Council meetings and appeal hearings; ensuring public access to City records; and advising and assisting with the availability, protection, and retention of City Records.

Department Programs

Public Records and City Council Meeting Management

3.8 FTE

Sister City

0.0 FTE

2007 City Clerk as a Share of the General Fund

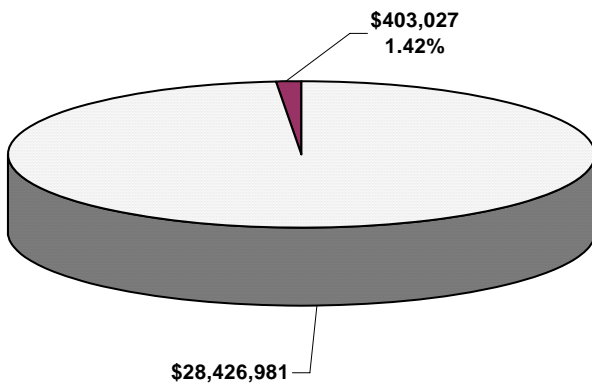

City Clerk Historical Comparison

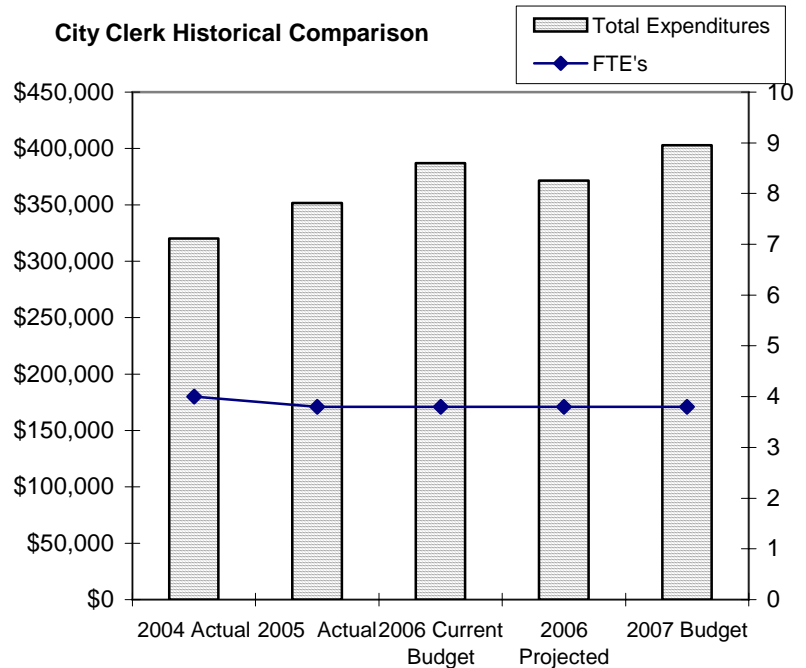



City Clerk 2007 Budget

2006 Key Department Accomplishments in Support of the City's Strategic Objectives:

Effective Citizen Communication and Engagement

- Implement and manage streaming video capability for on-demand viewing of City Council meetings from the City Web site
- Planned and coordinated activities of delegation invited to visit Shoreline's sister city, Boryeong, Korea

Governmental Excellence

- Complete development of City Clerk's Records database for the Portal
- Continue working with departments on development of their portal pages and with Information Systems on overall system design
- Implement training for staff on public records management and disclosure at time of hire
- Continue working with all departments in the protection of essential and permanent records to meet state requirements and to provide back-up in case of emergency
- Provide training to the City Council on parliamentary procedure
- Implement and manage e-mail archiving system to achieve search capability and retention management of e-mail records

Economic Vitality and Financial Stability

- Implement and manage a business registration program

2007 Key Department Objectives in Support of the City's Strategic Objectives:

Effective Citizen Communication and Engagement

- Implement web casting of Council meetings
- Coordinate hosting activities for visiting delegation from Boryeong, Korea

Governmental Excellence

- Continue working with departments on development of their portal pages and with Information Systems on overall system design
- Continue working with all departments in the protection of essential and permanent records to meet state requirements and to provide back-up in case of emergency



City Clerk 2007 Budget

City Clerk 2004 - 2007 Program Budget Comparison							
Program Expenditures	2004 Actual	2005 Actual	2006 Current Budget	2006 Projected	2007 Budget	2006 Current Budget versus 2007 Budget	Percentage Change
Public Records & City Council Management	\$314,775	\$351,677	\$380,159	\$365,393	\$397,027	\$16,868	4.44%
Sister City	\$5,395	\$0	\$7,000	\$6,000	\$6,000	-\$1,000	-14.29%
Total Program Budget	\$320,170	\$351,677	\$387,159	\$371,393	\$403,027	\$15,868	4.10%
Program Revenue							
Public Records & City Council Management	\$22,030	\$21,545	\$26,050	\$28,247	\$29,897	\$3,847	14.77%
Total Program Revenue	\$22,030	\$21,545	\$26,050	\$28,247	\$29,897	\$3,847	14.77%
General Fund Subsidy	\$298,140	\$330,132	\$361,109	\$343,146	\$373,130	\$12,021	3.33%
Total Resources	\$320,170	\$351,677	\$387,159	\$371,393	\$403,027	\$15,868	4.10%
Program Statistics							
FTE's	4	3.8	3.8	3.8	3.8	0	0.00%

2007 City Clerk Program Breakdown

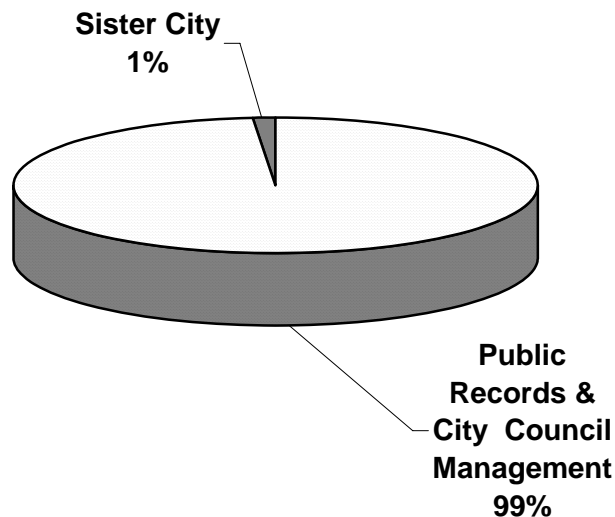



City Clerk 2007 Budget

City Clerk 2004 - 2007 Budget By Object							
Object Category	2004 Actual	2005 Actual	2006 Current Budget	2006 Projected	2007 Budget	2006 Current Budget versus 2007 Budget	Percentage Change
Salaries	\$196,240	\$211,501	\$219,857	\$208,170	\$222,695	\$2,838	1.3%
Personnel Benefits	\$57,353	\$60,785	\$66,752	\$70,552	\$79,807	\$13,055	19.6%
Supplies	\$8,033	\$8,314	\$8,500	\$5,700	\$7,500	-\$1,000	(11.8%)
Other Services & Charges	\$58,544	\$71,077	\$92,050	\$86,971	\$93,025	\$975	1.06%
Total Expenditures	\$320,170	\$351,677	\$387,159	\$371,393	\$403,027	\$15,868	4.10%
Revenue							
Licenses & Permits	\$20,907	\$20,405	\$24,530	\$24,480	\$24,530	\$0	0.00%
Charges for Goods and Services	\$1,123	\$1,140	\$1,520	\$3,767	\$5,367	\$3,847	253.09%
Miscellaneous Revenue	\$0	\$0	\$0	\$0	\$0	\$0	0.00%
Total City Clerk Revenue	\$22,030	\$21,545	\$26,050	\$28,247	\$29,897	\$3,847	14.77%
General Fund Subsidy	\$298,140	\$330,132	\$361,109	\$343,146	\$373,130	\$12,021	3.33%
Total Resources	\$320,170	\$351,677	\$387,159	\$371,393	\$403,027	\$15,868	4.10%
Department Statistics							
FTE's	4	3.8	3.8	3.8	3.8	0	0
% of General Fund	1.33%	1.19%	1.32%	1.27%	1.42%	0.10%	7.66%

PUBLIC RECORDS & CITY COUNCIL MEETING MANAGEMENT

PROGRAM PURPOSE:

The City Clerk's Office oversees the legal and efficient operation of City Council meetings and Hearing Examiner appeal hearings and manages the availability, protection and retention of City records to facilitate the democratic process for the citizens of Shoreline.

STRATEGIC OBJECTIVES:

Effective Citizen Communication and Engagement

Measurement: EFFECTIVENESS	2004	2005	2006	2007/Target
Percentage of City Council packets available to the public on the City website the day after receipt by City Councilmembers	97%	97%	100%	100%
Percentage of external customers who rate the City Clerk's public disclosure process as very good or excellent	94%	95%	95%	100%
Percentage of internal customers rating the City Clerk's Office services very good or excellent	99%	99%	99%	100%

Measurement: WORKLOAD	2004	2005	2006	2007/Target
Number of boxes of records accessioned into the Records Center	290	200	200	
Number of City Council packets and sets of minutes produced	37	42	42	
Number of contracts and property records, agreements processed, recorded, and/or filed	500	400	400	
Number of items uploaded to the web site or network	946	1,300	1,200	
Number of pages of public records provided	13,773	7,500	7,000	
Number of public records requests processed	192	165	150	
Number of specialty business licenses issued	202	193	152	

PUBLIC RECORDS & CITY COUNCIL MEETING MANAGEMENT

2006

Program Expenditures	\$	380,158
Program Revenue	\$	26,050
General Support	\$	354,108

Program Revenue vs General Support

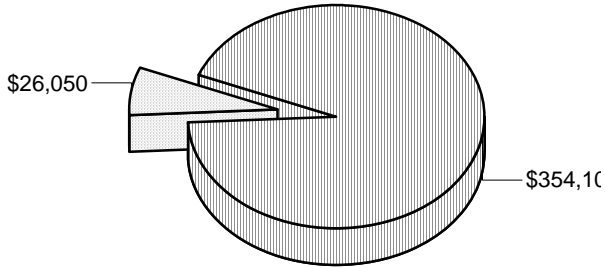

@Support	93.1%
@Revenue	6.9%
Total: 100.0%	

2007

Program Expenditures	\$	397,027
Program Revenue	\$	29,897
General Support	\$	367,130

Program Revenue vs General Support

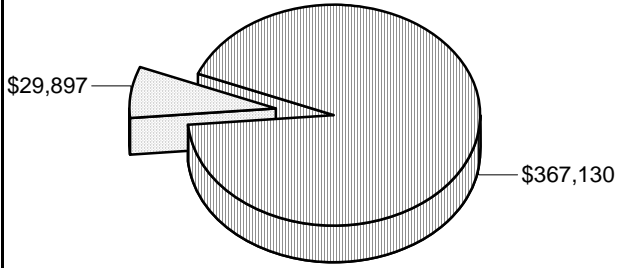

@Support	92.5%
@Revenue	7.5%
Total: 100.0%	

SISTER CITY RELATIONS

PROGRAM PURPOSE:

To seek international relationships which will enhance Shoreline citizens' understanding of other cultures, and/or which will allow the City to engage in productive and mutually beneficial exchanges of new technology, techniques, and solutions to problems with cities of comparable development.

STRATEGIC OBJECTIVES:

Effective Citizen Communication and Engagement

Measurement: WORKLOAD	2004	2005	2006	2007/Target
Number of Sister Cities Association meetings and events supported by City staff.	27	0	0	

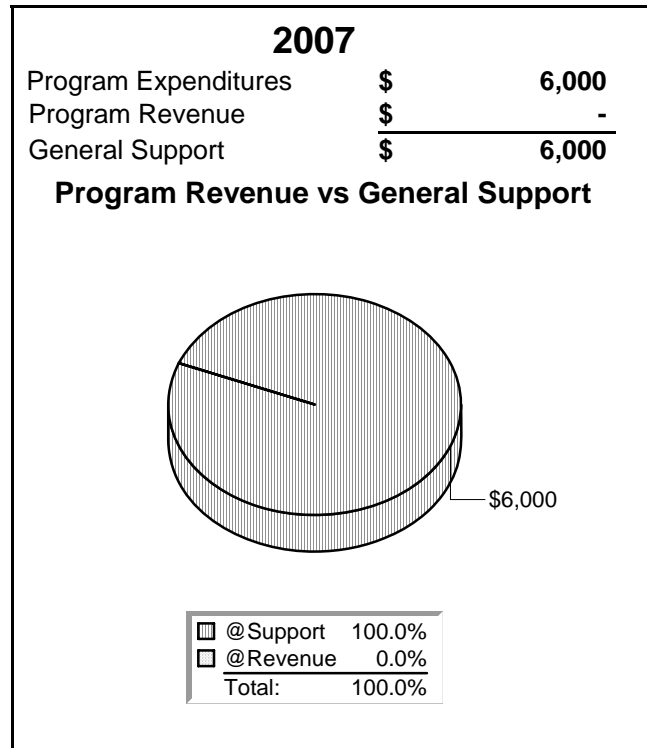
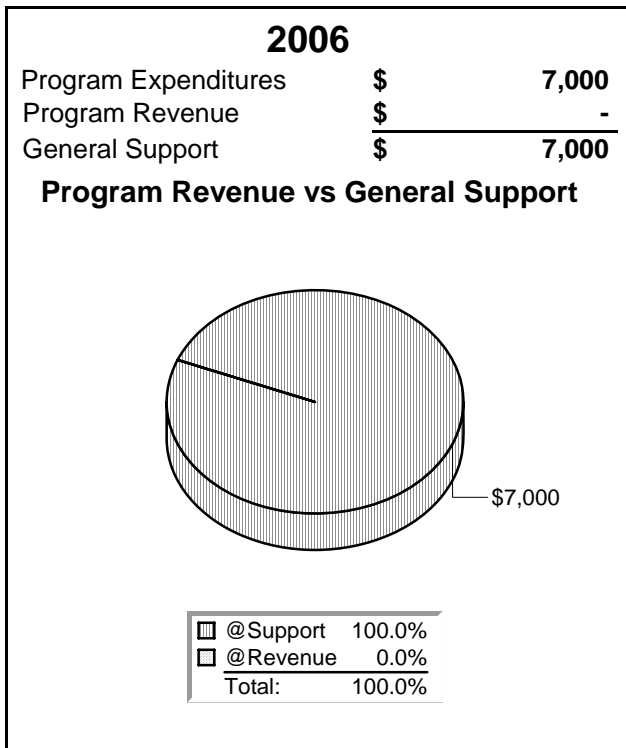



This Page Has Been Intentionally Left Blank



***Communications
&
Intergovernmental
Relations***



Communications and Intergovernmental Relations 2007 Budget

Mission Statement

The mission of Communications and Intergovernmental Relations is to create two-way communication among City government, Shoreline residents and other key stakeholders. Our goal is to encourage involvement in City decision making processes and enhance understanding and use of City services.

Department Programs

Communications

1.47 FTE

Intergovernmental Relations

0.56 FTE

Neighborhoods

1.47 FTE

2007 C&IR as a Share of the General Fund

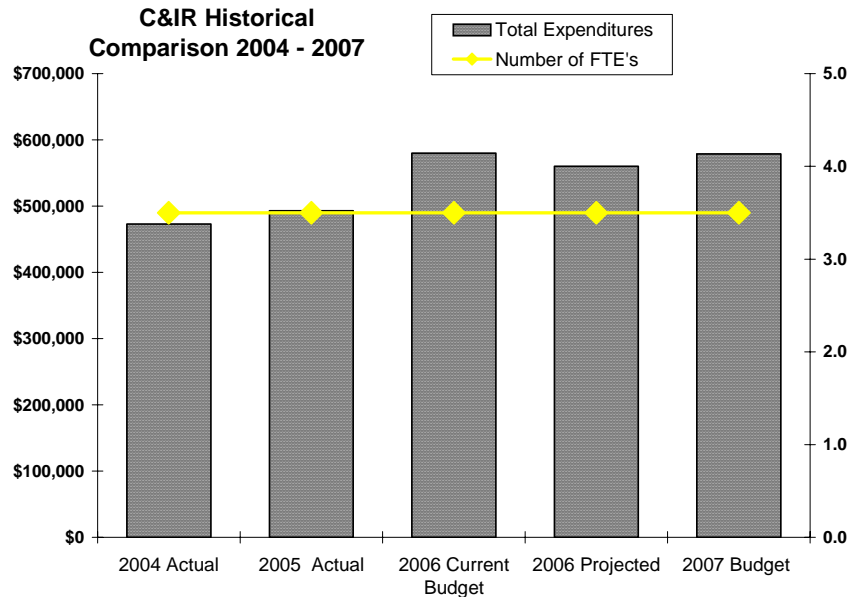
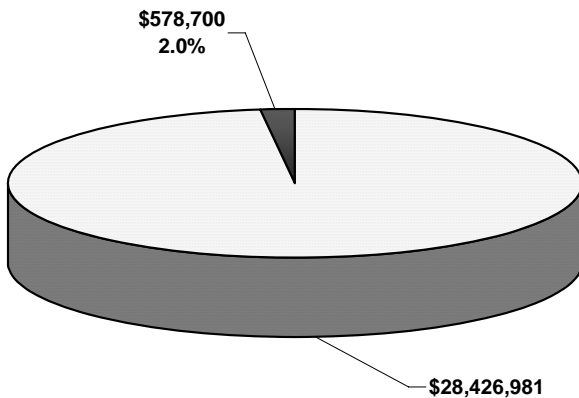



Communications and Intergovernmental Relations 2007 Budget

2006 Key Department Accomplishments in Support of the City's Strategic Objectives:

Effective Citizen Communication and Engagement

- Developed and implemented communication plans for economic development projects including: business enhancement activities for North City and Aurora; business directory for North City businesses; and Aurora business marketing materials.
- Developed and implemented communication plans for City projects such as the Aurora Corridor, North City, Interurban Trail, Sidewalk Program and Richmond Beach Saltwater Park Master Plan.
- Developed and implemented communication plans for key City Council goals, e. g., safe and friendly streets.
- Produced 10 issues of Currents newsletter including special budget issue.
- Developed and implemented communication pieces for the Park Bond Election and Council Goals Workshops.
- Developed Web pages for Park Bond and CIP Projects.
- Facilitated monthly Council of Neighborhoods meetings.
- Facilitated Council of Neighborhoods participation in City events such as Swingin' Summer's Eve, Celebrate Shoreline and National Night Out Against Crime.
- Conducted communication and temperament training for neighborhood leaders; provided technical assistance on newsletter and technology.
- Worked with consultant to produce 2006 Citizen Satisfaction Survey.
- Redesigned volunteer program to increase use of volunteers.
- Managed event planning and implementation for North City Ribbon-Cutting Ceremony, Aurora Corridor/Interurban Trail Bridges Girder Placements and Ribbon-Cutting Ceremony.
- Coordinated annual volunteer appreciation and recognition event.

Governmental Excellence

- Coordinated Council candidate information and orientation process.

Economic Vitality and Financial Stability

- Continued pursuing funding for City's capital projects through federal, state, regional and local funding sources.

Safe and Attractive Neighborhoods and Business Districts

- Council approved five Mini-Grants in 2006 to provide neighborhood enhancements.



Communications and Intergovernmental Relations 2007 Budget

2007 Key Department Objectives in Support of the City's Strategic Objectives:

Effective Citizen Communication and Engagement

- Continue to develop and implement communication plans and public outreach programs for Council goals and City's CIP Projects including Aurora Corridor, Interurban Trail, Parks Bond projects, economic development plan, code enforcement enhancements and safe and friendly streets
- Produce Currents newsletter 10 times a year and the City Source column in The Enterprise.
- Continue upgrading Web site and improving its utility to users including providing Council meeting videos via the Web site.
- Continue programming for Channel 21.
- Manage planning and implementation for groundbreakings, ribbon-cuttings and other ceremonial events.
- Update and publish 2008 edition of Owner's Manual.
- Facilitate Council of Neighborhoods meetings and participation in City events such as Swingin' Summer's Eve, Celebrate Shoreline and National Night Out.
- Implement city-wide volunteer program.
- Coordinate annual volunteer appreciation and recognition event.
- Provide training opportunities to neighborhood leaders.
- Develop communication pieces to implement the economic development program.

Economic Vitality and Financial Stability

- Continue to pursue state and federal funding for the Aurora Corridor, Interurban Trail and other key priorities in the CIP.

Safe and Attractive Neighborhoods and Business Districts

- Provide Mini-Grants for neighborhood safety and preparedness.
- Increase Block Watches.
- Expand Adopt-a-Road, -Park and Trail programs.
- Provide increased opportunity for youth safety.



Communications and Intergovernmental Relations 2007 Budget

Communications & Intergovernmental Relations 2004 - 2007 Budget Comparison By Program							
Expenditures by Objects	2004 Actual	2005 Actual	2006 Current Budget	2006 Projected	2007 Budget	2006 Current Budget versus 2007 Budget	
						Percentage Change	
Communications	\$246,164	\$262,859	\$290,273	\$290,273	\$282,303	-\$7,970	-2.75%
Intergov't'l Relations	\$90,167	\$108,821	\$105,634	\$106,639	\$115,749	\$10,115	9.58%
Neighborhoods	\$136,668	\$121,588	\$184,251	\$163,170	\$180,648	-\$3,603	-1.96%
Total Expenditures	\$472,999	\$493,268	\$580,158	\$560,082	\$578,700	-\$1,458	-0.25%
Revenue							
Other Revenues	\$0	\$0	\$0	\$20	\$0	\$0	0.00%
General Fund Subsidy	\$472,999	\$493,268	\$580,158	\$560,062	\$578,700	-\$1,458	-0.25%
Total Communication Resources	\$472,999	\$493,268	\$580,158	\$560,062	\$578,700	-\$1,458	-0.25%

2007 C&IR Program Breakdown

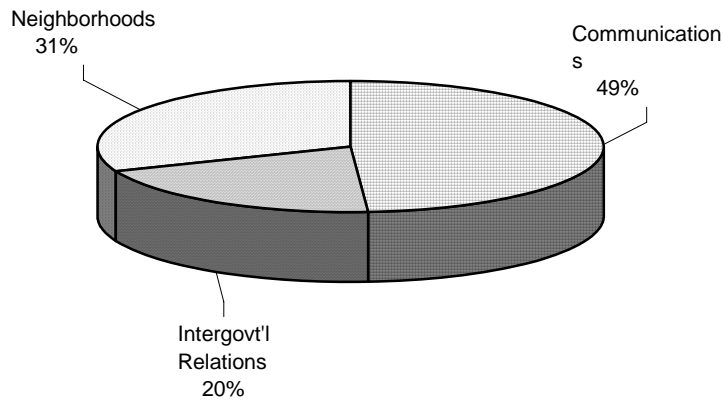



Communications and Intergovernmental Relations 2007 Budget

Communications & Intergovernmental Relations 2004 - 2007 Budget Comparison By Object							
Object Category Name	2006 Current					2006 Current Budget versus 2007 Budget	Percentage Change
	2004 Actual	2005 Actual	Budget	2006 Projected	2007 Budget		
Salary	\$219,620	\$220,495	\$236,312	\$236,434	\$253,373	\$17,061	7.22%
Benefits	\$50,238	\$51,765	\$58,530	\$58,530	\$74,446	\$15,916	27.19%
Supplies	\$8,751	\$9,365	\$6,650	\$11,550	\$10,000	\$3,350	50.38%
Other Services & Charges	\$194,390	\$211,643	\$278,666	\$253,568	\$240,881	-\$37,785	-13.56%
Intergovernmental Services	\$0	\$0	\$0	\$0	\$0	\$0	0.00%
Capital Outlays	\$0	\$0	\$0	\$0	\$0	\$0	0.00%
Total Expenditures	\$472,999	\$493,268	\$580,158	\$560,082	\$578,700	-\$1,458	-0.25%
Revenue							
Miscellaneous Revenues	\$0	\$0	\$0	\$20	\$0	\$0	0.00%
Total C&IR Revenue	\$0	\$0	\$0	\$20	\$0	\$0	0.00%
General Fund Subsidy	\$472,999	\$493,268	\$580,158	\$560,062	\$578,700	-\$1,458	-0.25%
Total C&IR Resources	\$472,999	\$493,268	\$580,158	\$560,082	\$578,700	-\$1,458	-0.25%
Department Statistics							
% of General Fund	1.96%	1.67%	1.97%	1.91%	2.04%	0.06%	3.2%
Number of FTE's	3.5	3.5	3.5	3.5	3.5	0.00	0.0%

2007 Key Department Highlights

- The 2007 Budget includes \$28,000 for the 2008 Owner's Manual.
- The 2007 Budget for Neighborhoods reprogrammed funds to implement volunteer programs including supplies, signs, printing, postage, publicity and related expenses, e.g., purchase of Adopt-A-Road safety equipment and supplies and other activities to accomplish Council Goal No. 10.
- The 2007 Budget for professional services within the Communications Program was reduced by \$17,500 compared to prior year budgets. These monies provided a contingency for contract writing services.

COMMUNICATIONS

PROGRAM PURPOSE:

The Communications program develops and uses two-way communication resources to deliver and elicit useful information to and from our residents and other key stakeholders.

STRATEGIC OBJECTIVES:

Effective Citizen Communication and Engagement

Measurement: EFFECTIVENESS	2004	2005	2006	2007/Target
Percentage of internal customers rating Communications overall services as good or excellent			93%	
Percentage of residents who are satisfied with public involvement in local decision-making	53%	53%		55%
Percentage of residents who are satisfied with quality of programming on City's Government Access Channel	44%	44%		45%
Percentage of residents who are satisfied with the quality of the City's newsletter, "Currents"	71%	71%		74%
Percentage of residents who are satisfied with the quality of the City's web site	47%	47%		49%

Measurement: WORKLOAD	2004	2005	2006	2007/Target
Number of Website visits	137,124	164,205	201,046	240,000

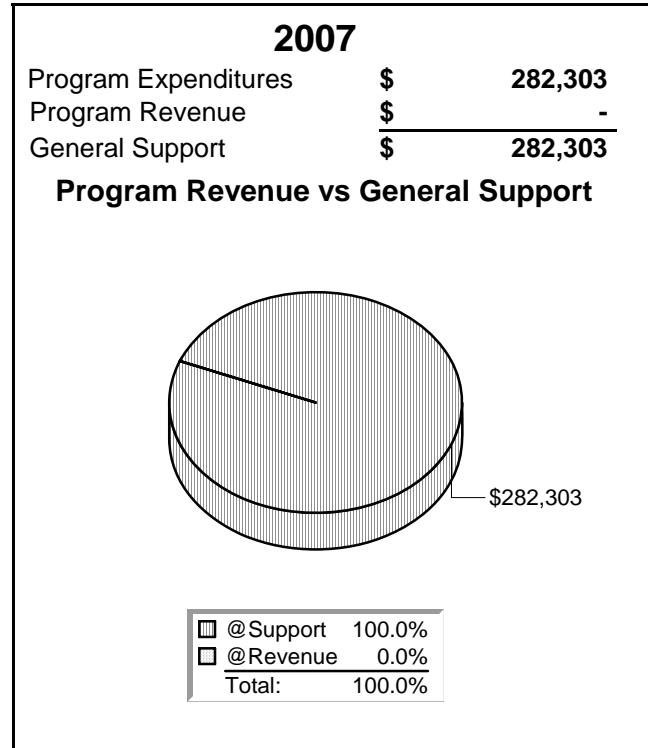
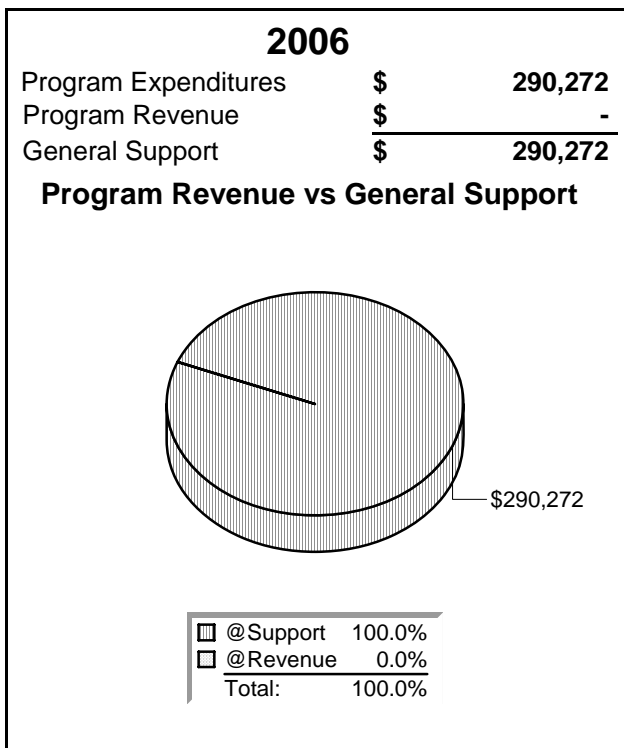

INTERGOVERNMENTAL RELATIONS

PROGRAM PURPOSE:

The Intergovernmental Relations program provides staff support for legislative objectives and intergovernmental alliances and partnerships that further the City's goals and priorities.

STRATEGIC OBJECTIVES:

Governmental Excellence

Measurement: EFFECTIVENESS	2004	2005	2006	2007/Target
Percentage of internal customers rating CIR overall services as good or excellent	N/A	N/A	95%	

Measurement: EFFICIENCY	2004	2005	2006	2007/Target
Intergovernmental Relations as a percentage of the City's operating budget	.4%	.4%	0.4%	

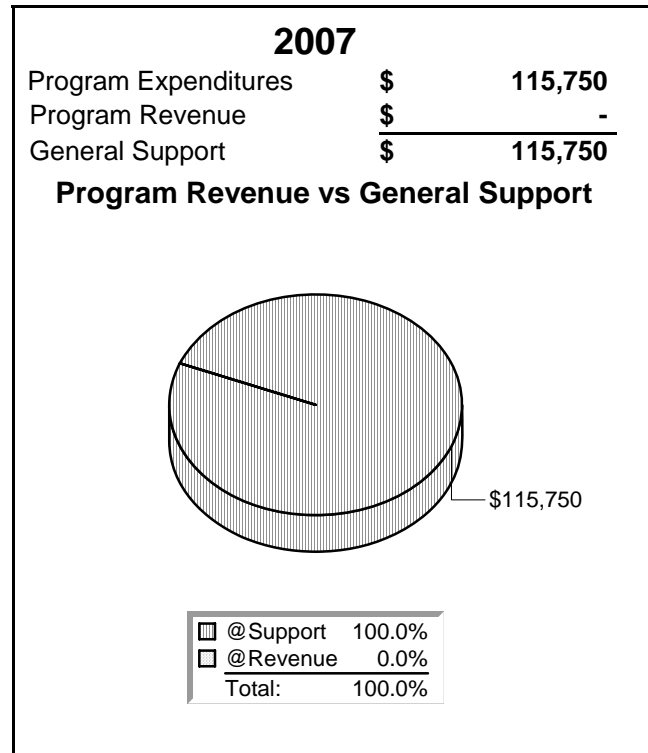
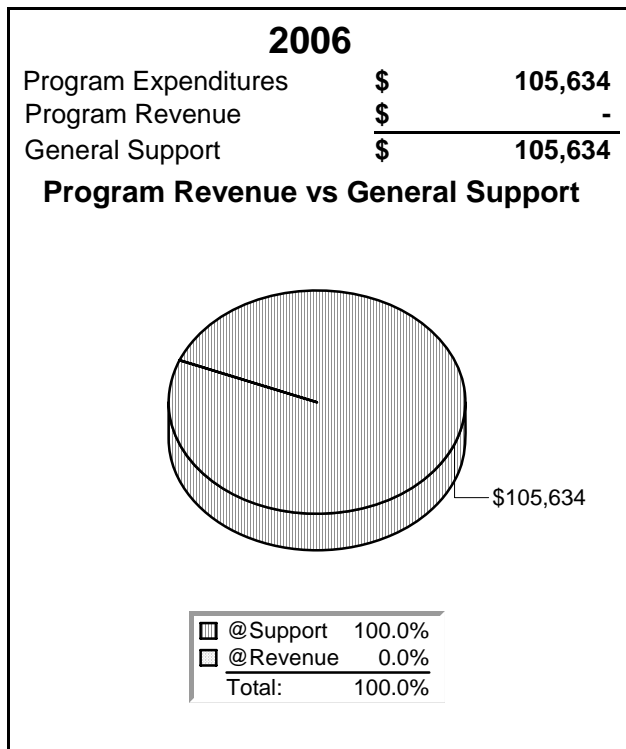

NEIGHBORHOODS

PROGRAM PURPOSE:

The Council of Neighborhoods was created in 1996 by City Council Resolution No. 54 to provide a vehicle for two-way communication between the City and its residents. The Neighborhoods program provides support, advice and assistance to the Council of Neighborhoods to build healthy, vibrant neighborhoods.

The Mini-Grant program was created in 1996 by City Council Resolution No. 54 to provide funding for neighborhood groups to make improvements that enhance the Shoreline community.

STRATEGIC OBJECTIVES:

Effective Citizen Communication and Engagement

Measurement: EFFECTIVENESS	2004	2005	2006	2007/Target
Percentage of internal customers rating neighborhoods overall services as good or excellent			80%	
Percentage of residents rating the condition of their neighborhoods as excellent or good	59%	59%		61%
Percentage of residents who think Shoreline is an excellent or good place to live	87%	87%		89%
Percentage of residents who think that the overall quality of life in the City is excellent or good	93%	93%		94%

Measurement: WORKLOAD	2004	2005	2006	2007/Target
Dollar value of improvements funded through the Mini-Grant program	\$8,797	\$11,101	\$26,137	\$30,000
Number of Neighborhoods/Grants	3	3	8	5

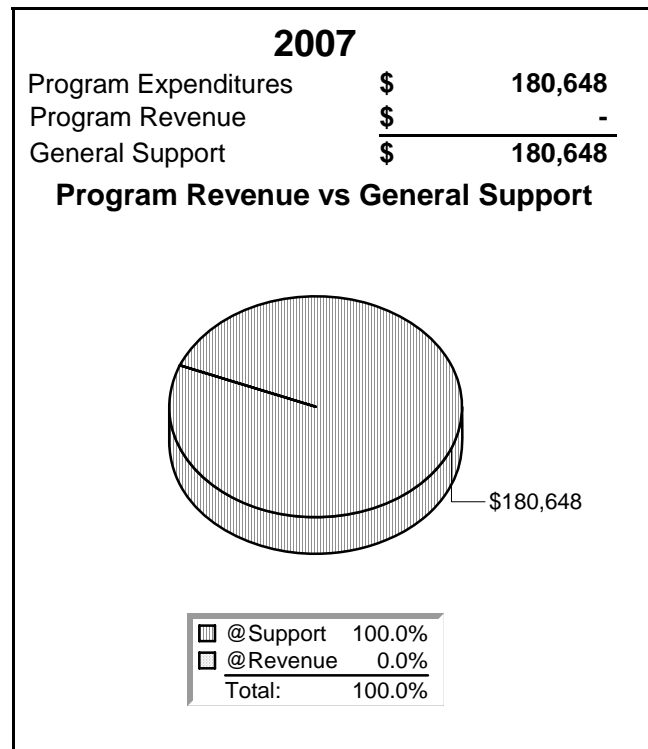
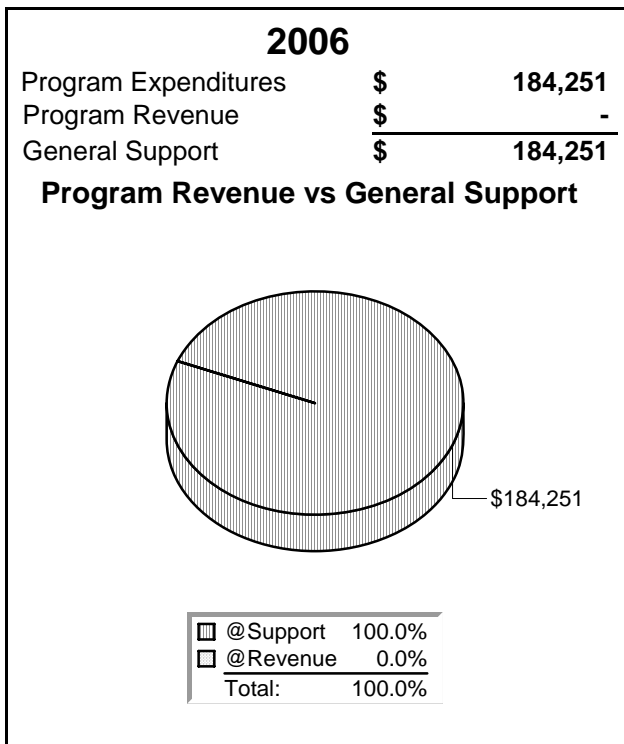



Human Services



Human Services 2007 Budget

Mission Statement

The mission of Human Services is to foster the development of a strong, safe and resilient community by serving as a catalyst and working with organizations and individuals to enable Shoreline citizens to meet their individual and family's needs for physical, mental, social and economic well being through an effective and accessible system of services.

Department Program

Support for Social Agencies

1.8 FTE

2007 Human Services as a Share of the General Fund

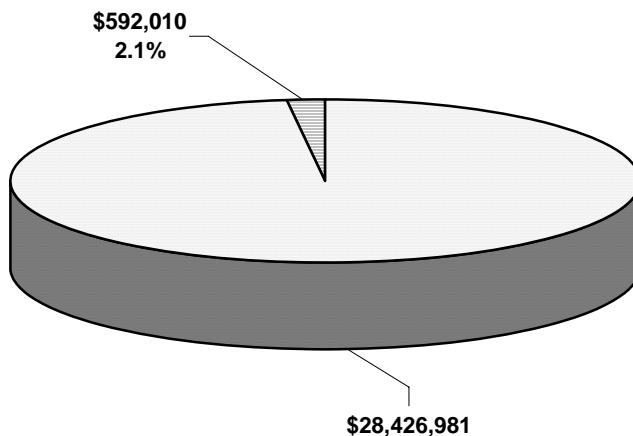

Human Services Historical Comparison 2004 - 2007

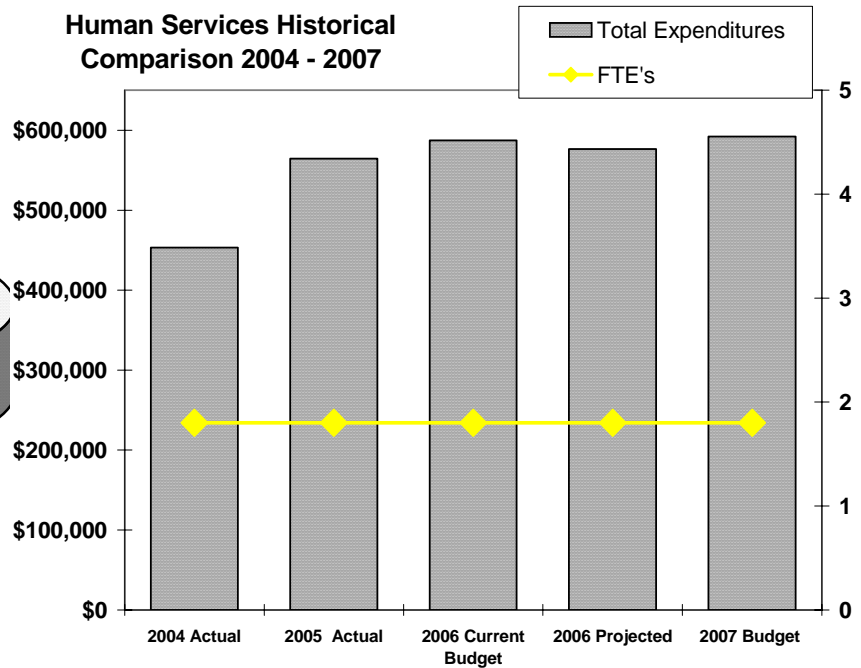



Human Services 2007 Budget

2006 Key Department Accomplishments in Support of the City's Strategic Objectives:

Human Services

- Conducted bi-annual Human Services application and review process with 8 citizen volunteers reviewing 36 agency applications
- Addressed hunger and food anxiety concerns facing Shoreline citizens by organizing and coordinating new food drives targeted to Shoreline
- Assessed housing needs for persons with limited incomes leading to development of an overall Housing Strategy
- Endorsed the county wide Ten Year Plan to End Homelessness
- Maintained strong partnerships with Shoreline Public Schools and among human services agencies and coalitions including the Shoreline Public Schools, United Way, North Urban Human Services Alliance

2007 Key Department Objectives in Support of the City's Strategic Objectives:

Human Services

- Enhance other funders', e.g. United Way, local civic groups and governments' understanding of Shoreline's human services needs
- Implement Council's high priority human services strategies
- Maintain strong partnership with Shoreline Public Schools, United Way, and service providers in order to identify and address critical and changing needs in the community
- Update youth strategies
- Review and update "Human Services Outcomes"



Human Services 2007 Budget

Human Services Program 2004 - 2007 Budget Comparison By Program							
Program Budget	2004 Actual	2005 Actual	2006 Current Budget	2006 Projected	2007 Budget	2006 Current Budget versus 2007 Budget	Percentage Change
Support for Social Agencies	\$453,325	\$564,457	\$587,209	\$576,397	\$592,010	\$4,801	0.82%
Total Expenditures	\$453,325	\$564,457	\$587,209	\$576,397	\$592,010	\$4,801	0.82%
Program Revenue							
Program Revenue	\$140,143	\$166,573	\$151,859	\$148,590	\$152,070	\$211	0.14%
Total Resources	\$140,143	\$166,573	\$151,859	\$148,590	\$152,070	\$211	0.14%
Department Statistics							
FTE's	1.80	1.80	1.80	1.80	1.80	0	0.00%

Human Services 2004 - 2007 Budget Comparison By Object							
Object Category	2004 Actual	2005 Actual	2006 Current Budget	2006 Projected	2007 Budget	2006 Current Budget versus 2007 Budget	Percentage Change
Salaries	\$121,478	\$123,294	\$125,931	\$126,074	\$131,214	\$5,283	4.20%
Personnel Benefits	\$30,892	\$31,605	\$34,294	\$34,310	\$39,626	\$5,332	15.55%
Supplies	\$1,216	\$294	\$1,200	\$1,272	\$1,600	\$400	33.33%
Other Services & Charges	\$299,739	\$409,264	\$425,784	\$414,741	\$419,570	-\$6,214	-1.46%
Intergovernmental Services	\$0	\$0	\$0	\$0	\$0	\$0	0.00%
Total Expenditures	\$453,325	\$564,457	\$587,209	\$576,397	\$592,010	\$4,801	0.82%
Revenue							
Intergovernmental Revenue	\$140,143	\$166,573	\$151,859	\$148,590	\$152,070	\$211	0.14%
Total Human Services Revenue	\$140,143	\$166,573	\$151,859	\$148,590	\$152,070	\$211	0.14%
General Fund Subsidy	\$313,182	\$397,884	\$435,350	\$427,807	\$439,940	\$4,590	1.05%
Total Resources	\$453,325	\$564,457	\$587,209	\$576,397	\$592,010	\$4,801	0.82%
Department Statistics							
FTE's	1.80	1.80	1.80	1.80	1.80	0	0.00%
% of General Fund	1.9%	1.9%	2.0%	2.0%	2.1%	0.09%	4.26%

2007 Department Highlights

- To maintain current levels of the Human Service funding a \$10,000 or 4% increase in general fund contribution has been included in the proposed budget.
- The 2006 current budget includes \$20,000 in one-time funding for the development of a youth services master plan. The 2007 budget does not include this amount.

HUMAN SERVICES: SUPPORT FOR SOCIAL AGENCIES

PROGRAM PURPOSE:

Human Services fosters the development of an effective and accessible system of human services to meet the needs of Shoreline residents.

STRATEGIC OBJECTIVES:

Human Services

Measurement: EFFECTIVENESS	2004	2005	2006	2007/Target
Percent of Shoreline residents served in "A Safe Haven From All Forms of Violence and Abuse" service area.	0.2%	0.3%	0.3%	0.3%
Percent of Shoreline residents served in "Educational and Job Skills" service area.	N/A	0.8%	0.21%	0.1%
Percent of Shoreline residents served in "Food to Eat and a Roof Overhead" service area.	15.3%	13.6%	8.3%	8.5%
Percent of Shoreline residents served in "Health Care" service area.	N/A	0.5%	0.4%	0.03%
Percent of Shoreline residents served in "Supportive Relationships" service area.	15.2%	14.8%	12.75%	12.59%
Percentage of service goals met by human service contractors	85%	84%	85%	80%

Measurement: EFFICIENCY	2004	2005	2006	2007/Target
Program cost per capita	\$8.60	\$11.43	\$10.80	
Program expenditures as a percentage of City's operating budget	1.8%	2.3%	2.1%	

Measurement: WORKLOAD	2004	2005	2006	2007/Target
Number of citizens receiving emergency food and shelter	1,974	2,116	2,050	2,113
Number of major home repair projects completed	21	16	12	14
Number of minor home repairs completed.	N/A	25	35	30
Number of older adults receiving congregate meals and home delivered meals	413	350	325	285
Number of Shoreline Residents served in "A Safe Haven from all Forms of Violence and Abuse" service area.	127	170	110	130
Number of Shoreline Residents served in "Educational and Job Skills" service area.	N/A	416	110	42
Number of Shoreline Residents served in "Food to Eat and a Roof Overhead" service area.	8,092	7,146	4,400	4,476
Number of Shoreline Residents served in "Health Care" service area.	N/A	280	200	16
Number of Shoreline Residents served in "Supportive Relationships" service area.	8,038	5,610	6,735	6,651

HUMAN SERVICES: SUPPORT FOR SOCIAL AGENCIES

	2004	2005	2006	2007/Target
Number of Shoreline residents served through contracts	16,257	15,790	N/A	N/A
Number of unduplicated Shoreline residents served through contracts	N/A	N/A	11,445	11,273

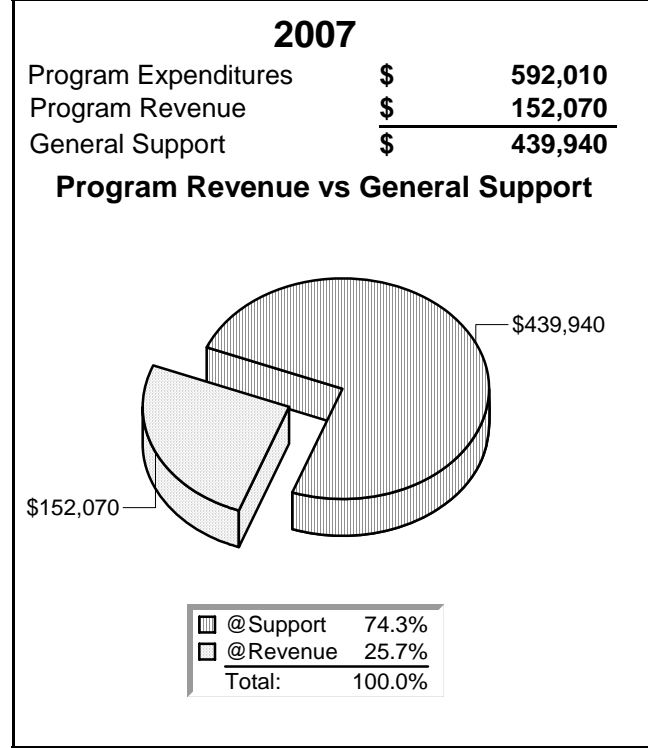
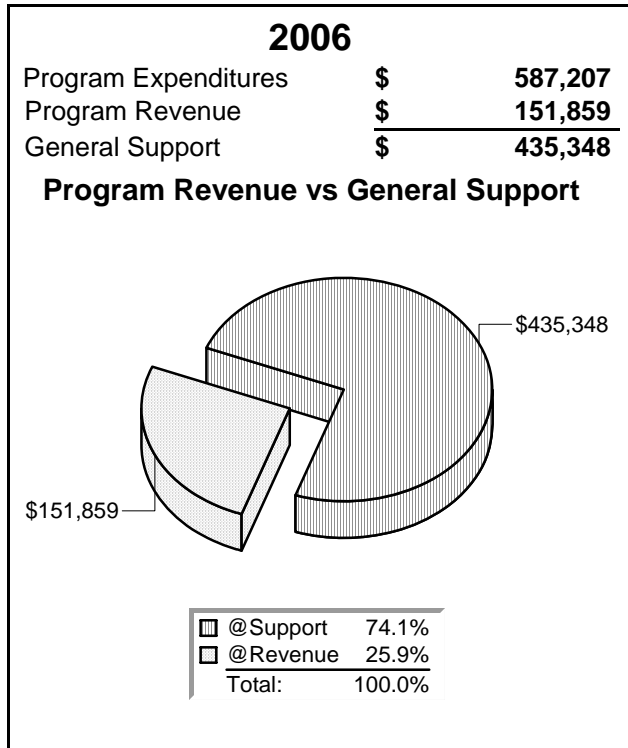



This Page Has Been Intentionally Left Blank



City Attorney



City Attorney 2007 Budget

“The City Attorney provides accurate and timely legal advice to the Council, City departments and advisory boards and commissions to improve effectiveness and minimize risk of City operations and oversees criminal justice services to the public”

Department Program and Activities

Legal Services
3.00 FTE

Prosecuting Attorney & Domestic Violence Victim Advocacy
0.0 FTE
(Contracted Service)

2007 City Attorney as a Share of the General Fund

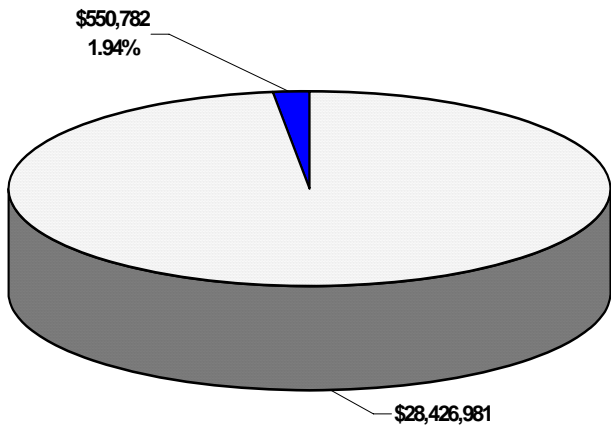

City Attorney Historical Comparison

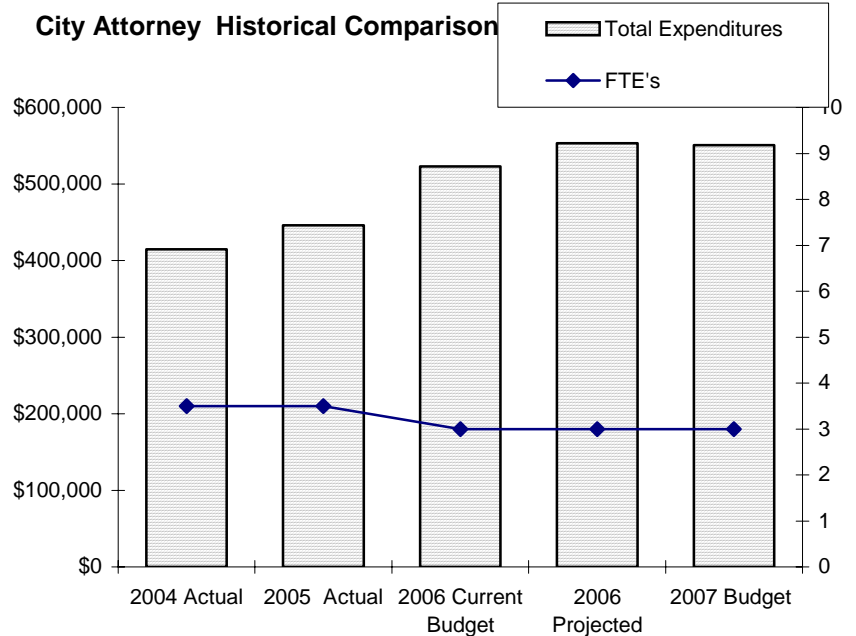



City Attorney 2007 Budget

2006 Key Department Accomplishments in Support of the City's Strategic Objectives:

Quality Services, Facilities and Infrastructure

- Completed Civic Center site acquisition
- Completed last three Interurban Trail property acquisitions
- Completed acquisition of park bond properties (South Woods, Hamlin Park addition, Kruckeberg Gardens)
- Completed right of way acquisition settlements for Aurora Improvements - 145th to 165th project

Governmental Excellence

- Defense of Seattle City Light and Seattle Public Utility litigation challenging franchise fees and hydrant costs.
- Negotiated Seattle Public Utility franchise extension
- Negotiated a long-term Municipal Court service contract

Safe and Attractive Neighborhoods and Business Districts

- Successfully defended four administrative and six court appeals of code enforcement and land use decisions
- Crafted Critical Area Ordinance and Hazardous Tree amendments
- Completed Critical Area Ordinance piped streams review

2007 Key Department Objectives in Support of the City's Strategic Objectives:

Governmental Excellence

- Coordinate development of a city-wide collection policy and procedures

Safe and Attractive Neighborhoods and Business Districts

- Review the Shoreline Community College Master Plan



City Attorney 2007 Budget

City Attorney 2004 - 2007 Budget Comparison By Program							
Program Budget	2004 Actual	2005 Actual	2006 Current Budget	2006 Projected	2007 Budget	2006 Current Budget versus 2007 Budget	Percentage Change
Legal Services	\$269,147	\$300,871	\$370,040	\$400,040	\$382,782	\$12,742	3.44%
Prosecuting Attorney	\$105,000	\$115,086	\$153,000	\$153,000	\$168,000	\$15,000	9.80%
Domestic Violence Victim Advocacy	\$40,823	\$30,040	\$0	\$0	\$0	\$0	0.00%
Total Expenditures	\$414,970	\$445,997	\$523,040	\$553,040	\$550,782	\$27,742	5.30%
Program Revenue							
Other Revenue	\$0	\$0	\$0	\$0	\$0	\$0	0.00%
General Fund Subsidy	\$414,970	\$445,997	\$523,040	\$553,040	\$550,782	\$27,742	5.30%
Total Resources	\$414,970	\$445,997	\$523,040	\$553,040	\$550,782	\$27,742	5.30%

2007 City Attorney Program Breakdown

Prosecuting Attorney
(Includes Domestic Violence advocacy)
31%

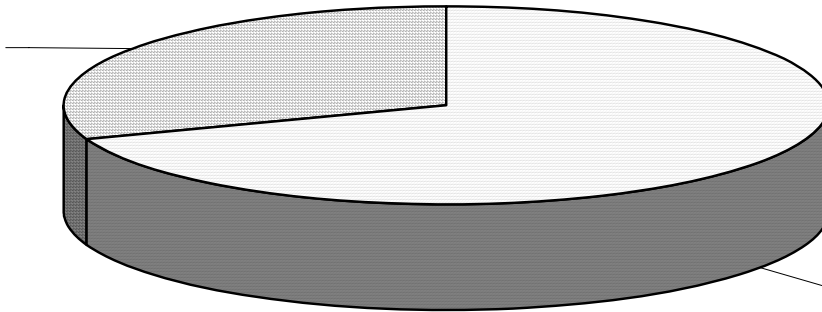

Legal Services
69%



City Attorney 2007 Budget

City Attorney 2004 - 2007 Budget Comparison By Object							
Object Category	2004 Actual	2005 Actual	2006 Current Budget	2006 Projected	2007 Budget	2006 Current Budget versus 2007 Budget	Percentage Change
Salaries	\$216,219	\$217,159	\$229,389	\$229,389	\$247,392	\$18,003	7.85%
Benefits	\$51,052	\$50,469	\$53,035	\$53,035	\$62,774	\$9,739	18.36%
Supplies	\$1,757	\$1,150	\$2,000	\$2,000	\$2,000	\$0	0.00%
Other Services & Charges	\$145,942	\$177,219	\$238,616	\$268,616	\$238,616	\$0	0.00%
Intergovernmental Services	\$0	\$0	\$0	\$0	\$0	\$0	0.00%
Capital Outlays	\$0	\$0	\$0	\$0	\$0	\$0	0.00%
Interfund Payments for Service	\$0	\$0	\$0	\$0	\$0	\$0	0.00%
Total Expenditures	\$414,970	\$445,997	\$523,040	\$553,040	\$550,782	\$27,742	5.30%
Revenue							
Other Revenue	\$0	\$0	\$0	\$0	\$0	\$0	0.00%
General Fund Subsidy	\$414,970	\$445,997	\$523,040	\$553,040	\$550,782	\$27,742	5.30%
Total Resources	\$414,970	\$445,997	\$523,040	\$553,040	\$550,782	\$27,742	5.30%
Department Statistics							
FTE's	3.50	3.50	3.00	3.00	3.00	0	0.00%
% of General Fund	1.7%	1.5%	1.8%	1.9%	1.9%	0.16%	8.90%

2007 Key Department Highlights

- The 2007 Budget for professional services in the Legal program was reduced by \$15,000 when compared to prior years. These monies were budgeted as a contingency for external contracts for legal matters.
- The 2007 Budget for the Prosecuting Attorney program has been increased by \$15,000 in the operating rentals and leases line item. King County is now requiring the City to pay for the office space of the prosecuting attorney at the District Court offices.

LEGAL SERVICES

PROGRAM PURPOSE:

The City Attorney provides accurate and timely legal advice to the Council, City departments and advisory boards and commissions to improve effectiveness and minimize risk of City operations

STRATEGIC OBJECTIVES:

Governmental Excellence

Measurement: EFFECTIVENESS	2004	2005	2006	2007/Target
Percentage of customers rating timeliness of legal services as good or excellent	79.2%	79.2%	81%	
Percentage of internal customers rating legal Services overall as good or excellent	94.5%	94.5%	84%	

Measurement: EFFICIENCY	2004	2005	2006	2007/Target
Program budget as a percent of the City's operating budget	1.1%	1.2%	1.4%	

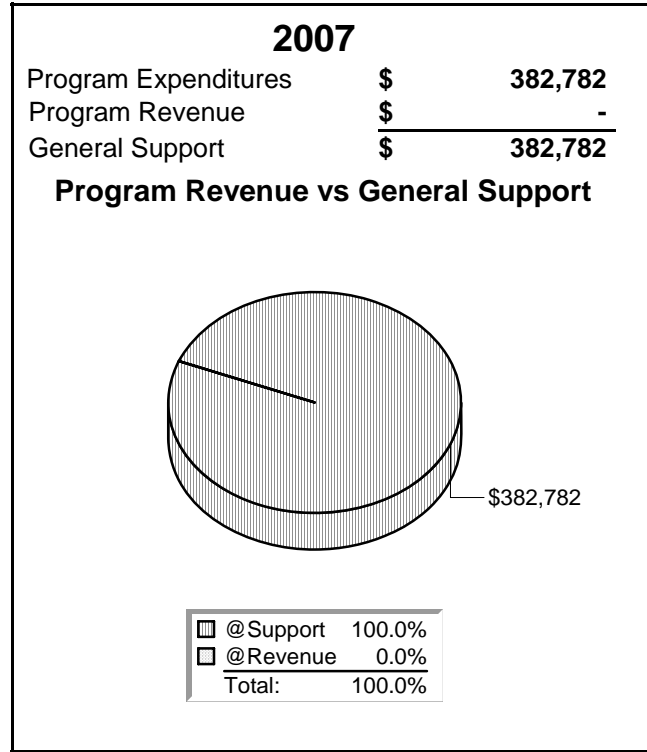
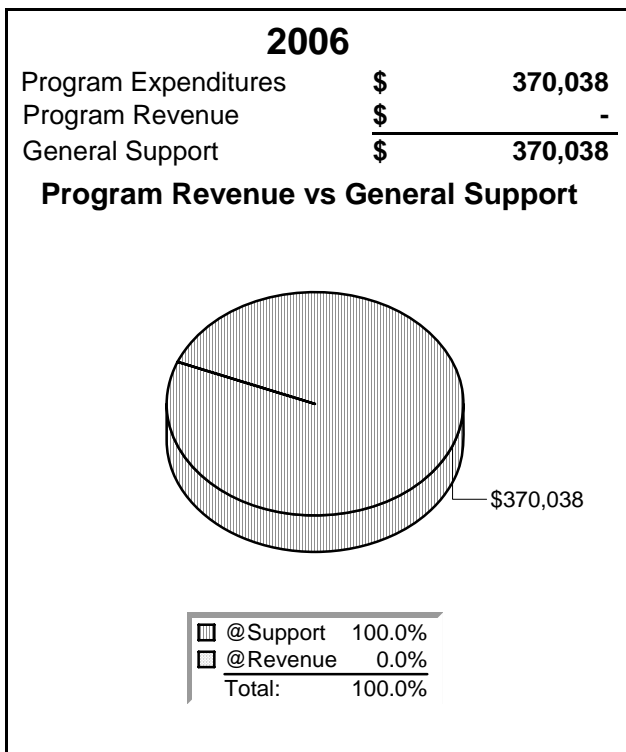

PROSECUTING ATTORNEY

PROGRAM PURPOSE:

The Prosecuting Attorney prosecutes violations of the Shoreline Municipal Code.

STRATEGIC OBJECTIVES:

Safe and Attractive Neighborhoods and Business Districts

Measurement: WORKLOAD	2004	2005	2006	2007/Target
Total Number of Criminal Cases	906	970	1,243	

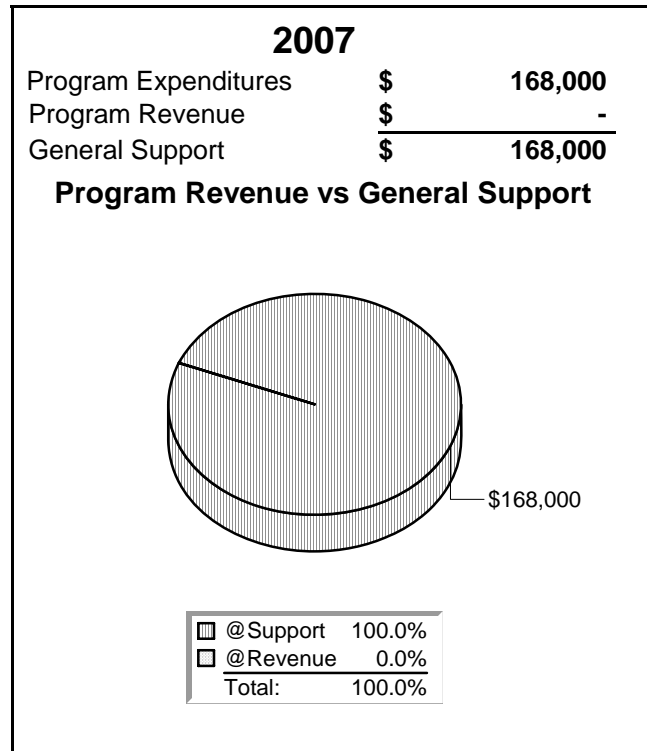
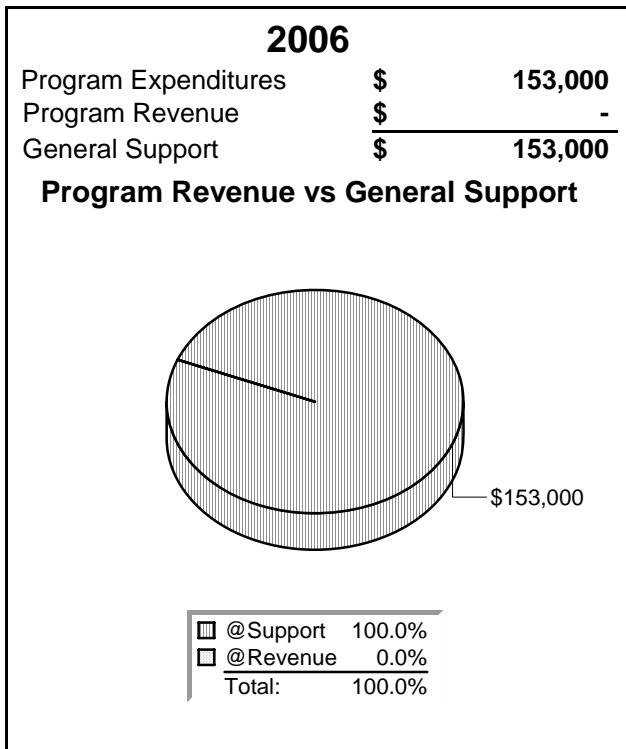



Finance



Finance 2007 Budget

Mission Statement

The Finance Department provides excellent and innovative financial and technological services to City Departments for the purpose of enhancing the community of Shoreline.

Department Programs

**Financial Planning
and Accounting
Services**

8.63 FTE

**Purchasing
Services**

1.75 FTE

**IT Strategic Plan
Implementation**

2.35 FTE

**IT Operations &
Security
Administration**

3.6 FTE

**Geographical
Information
Services**

1.05 FTE

**Intergovernmental
Participation**

0.0 FTE

Grant Development

0.2 FTE

*An additional .5 FTE is budgeted in the
Capital Funds



Finance 2007 Budget

2007 Finance as a Share of the General Fund

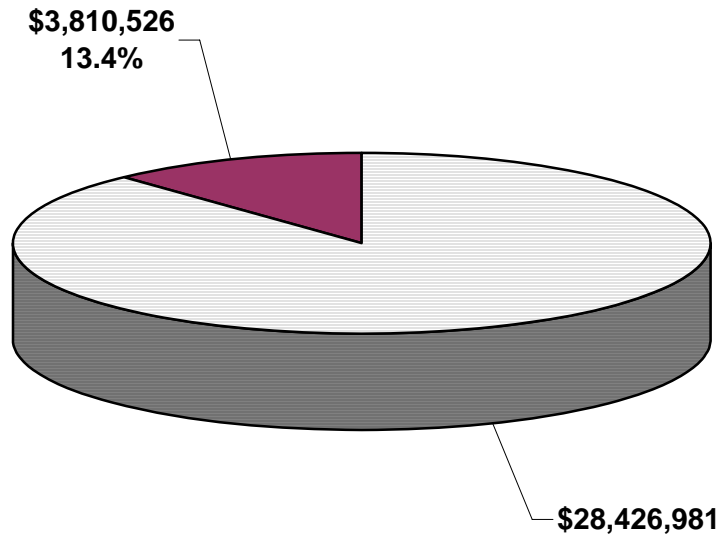

Finance Historical Comparison

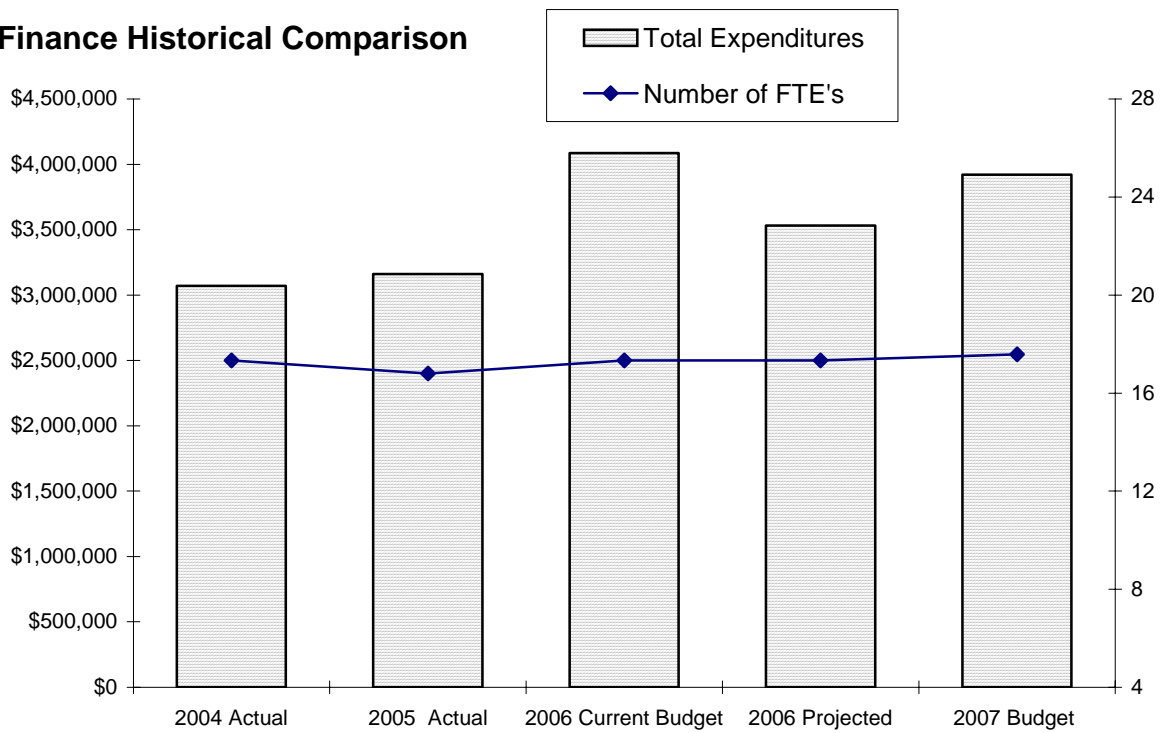



Finance 2007 Budget

2006 Key Department Accomplishments in Support of the City's Strategic Objectives:

Economic Vitality and Financial Stability

- Updated the City's long-range financial forecast for 2007-2012 in April and September 2006
- Worked with departments to complete operational and capital grant applications
- Exceeded investment policy benchmark for investment returns by 22 basis points
- Applied for and received grant awards in support of Council Goal Nos. 1, 4, 7, and 9
- Completed the City's first general obligation bond sale of \$18.8 million and received the City's first bond rating

Effective Citizen Communication and Engagement

- Assisted in the facilitation of community workshops to help identify city-wide community goals

Governmental Excellence

- Produced 2005 financial statements in compliance with GASB 34 that met all State Audit requirements and resulted in a "clean" audit opinion
- Launched the Finance Department Community on the City's Portal
- Received the Government Finance Officers Association Budget Award with several rating areas receiving "outstanding" ratings

Quality Services, Facilities and Infrastructure

- Facilitated the development of the 2007-2012 Capital Improvement Program that was adopted by the City Council in July
- Continued implementation of the City's 2003-2006 IT Strategic Plan
- Conducted second internal customer service satisfaction survey with the Finance Department receiving 92% good or excellent ratings



Finance 2007 Budget

2007 Key Department Objectives in Support of the City's Strategic Objectives:

Economic Vitality and Financial Stability

- Continue to support the Aurora Corridor and other capital projects through grant writing and grant application
- Monitor the first year of the City's business registration program
- Continue to seek grant funding in support of emergency management activities
- Update and implement the long-range financial plan
- Continue to seek grants in support of enhancing our program for safe and friendly streets

Effective Citizen Communication and Engagement

- Enhance the ability of residents and local businesses to participate in the City's prioritization and budget processes by providing public forums to discuss community priorities.
- Increase the Community's understanding of financial practices and financial condition
- Update performance measures
- Implement web casting of Council meetings

Governmental Excellence

- Implement the first year of the 2007-2009 Information Technology strategic plan
- Continue the implementation of the Performance Measurement Program

Safe and Attractive Neighborhoods and Business Districts

- Develop a Capital Improvement Plan for 2008-2013 that meets the City's infrastructure needs within the City's financial capacity

Quality Services, Facilities and Infrastructure

- Update performance measures and targets



Finance 2007 Budget

Finance 2004 - 2007 Budget Comparison By Programs							
Object Category Name	2006 Current					2006 Current	Percentage Change
	2004 Actual	2005 Actual	Budget	2006 Projected	2007 Budget	Budget versus 2007 Budget	
Financial Planning & Accounting Services	\$678,333	\$679,236	\$733,267	\$704,538	\$765,383	\$32,116	4.38%
Purchasing Services	\$168,594	\$172,643	\$191,123	\$185,818	\$210,451	\$19,328	10.11%
Geographical Information Services	\$161,507	\$154,450	\$183,357	\$183,192	\$185,234	\$1,877	1.02%
Information Technology Operations & Security	\$754,231	\$712,317	\$809,627	\$842,024	\$904,387	\$94,760	11.70%
Information Technology Strategic Plan Implementation	\$428,079	\$477,777	\$355,628	\$352,846	\$346,475	-\$9,153	-2.57%
Grant Research	\$12,378	\$15,744	\$17,396	\$17,775	\$18,672	\$1,276	7.34%
Intergovernmental Participation	\$94,581	\$98,943	\$105,380	\$101,083	\$101,987	-\$3,393	-3.22%
Non-Program Expenses (Citywide, Equipment Replacement, Unemployment)	\$771,207	\$849,853	\$1,690,050	\$1,145,952	\$1,387,936	-\$302,114	-17.88%
Total Expenditures	\$3,068,910	\$3,160,963	\$4,085,828	\$3,533,228	\$3,920,526	-\$165,302	-4.05%
Revenue							
Financial Planning & Accounting Services	\$1,800	\$1,808	\$1,800	\$1,800	\$1,800	\$0	0.00%
Purchasing Services	\$0	\$0	\$0	\$0	\$0	\$0	0.00%
Geographical Information Services	\$0	\$0	\$0	\$0	\$0	\$0	0.00%
Information Technology Operations & Security Administration	\$0	\$285	\$0	\$29	\$0	\$0	0.00%
Information Technology Strategic Plan Implementation	\$0	\$0	\$0	\$0	\$0	\$0	0.00%
Grant Research	\$0	\$0	\$0	\$0	\$0	\$0	0.00%
Intergovernmental Participation	\$0	\$0	\$0	\$0	\$0	\$0	0.00%
Non-Program Expenses (Citywide, Equipment Replacement, Unemployment)	\$341,694	\$320,377	\$309,758	\$375,448	\$331,069	\$21,311	6.88%
Total Finance Revenue	\$343,494	\$322,470	\$311,558	\$377,277	\$332,869	\$21,311	6.84%
General Fund Subsidy	\$2,725,416	\$2,838,493	\$3,774,270	\$3,155,951	\$3,587,657	-\$186,613	-4.94%
Total Resources	\$3,068,910	\$3,160,963	\$4,085,828	\$3,533,228	\$3,920,526	-\$165,302	-4.05%
Department Statistics							
Number of FTE's	17.33	16.8	17.33	17.33	17.58	0.25	1.44%

2007 Finance Program Breakdown

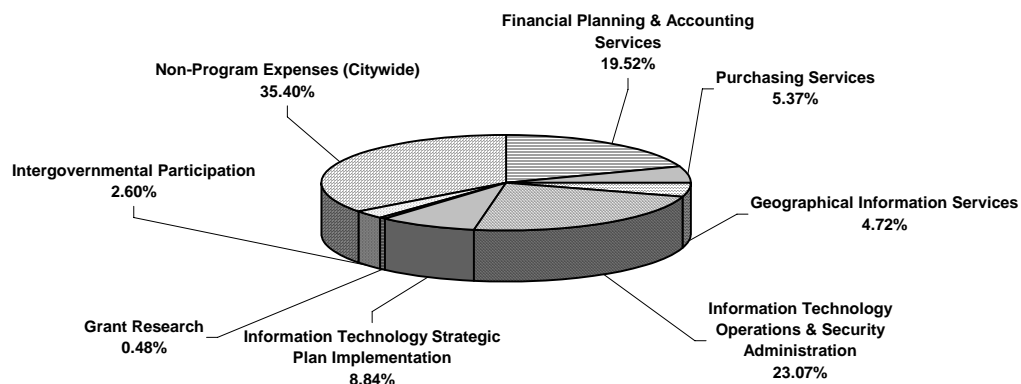



Finance 2007 Budget

Finance 2004 - 2007 Operating Budget Comparison By Object							
Object Category Name	2006 Current					2006 Current	Percentage Change
	2004 Actual	2005 Actual	Budget	2006 Projected	2007 Budget	Budget versus 2007 Budget	
Salary	\$1,063,514	\$1,062,868	\$1,224,944	\$1,155,619	\$1,269,344	\$44,400	3.62%
Benefits	\$254,025	\$268,275	\$299,015	\$295,718	\$355,232	\$56,217	18.80%
Supplies	\$256,365	\$244,861	\$185,038	\$196,945	\$152,063	-\$32,975	-17.82%
Other Services & Charges	\$1,152,508	\$1,285,699	\$1,225,548	\$1,449,181	\$1,287,465	\$61,917	5.05%
Intergovernmental Services	\$187,710	\$89,451	\$239,925	\$285,650	\$161,779	-\$78,146	-32.57%
Capital Outlays	\$86,805	\$132,646	\$79,580	\$70,000	\$64,000	-\$15,580	-19.58%
Interfund Payments for Service and Contingencies	\$67,983	\$77,163	\$831,778	\$80,115	\$630,643	-\$201,135	-24.18%
Total Expenditures	\$3,068,910	\$3,160,963	\$4,085,828	\$3,533,228	\$3,920,526	-\$165,302	-4.05%
Revenue							
Licenses and Permits	\$0	\$0	\$0	\$0	\$0	\$0	0.00%
Intergovernmental Revenues	\$0	\$0	\$0	\$0	\$0	\$0	0.00%
Charges for Goods and Services	\$1,800	\$1,800	\$1,800	\$1,800	\$1,800	\$0	0.00%
Miscellaneous Revenues	\$201,694	\$210,670	\$199,758	\$245,477	\$221,069	\$21,311	10.67%
Other Financing Sources	\$140,000	\$110,000	\$110,000	\$130,000	\$110,000	\$0	0.00%
Total Finance Revenue	\$343,494	\$322,470	\$311,558	\$377,277	\$332,869	\$21,311	6.84%
General Fund Subsidy	\$2,725,416	\$2,838,493	\$3,774,270	\$3,155,951	\$3,587,657	-\$186,613	-4.94%
Total Resources	\$3,068,910	\$3,160,963	\$4,085,828	\$3,533,228	\$3,920,526	-\$165,302	-4.05%
Department Statistics							
% of General Fund	12.7%	10.7%	13.9%	12.1%	13.4%	(0.49%)	-3.6%
Number of FTE's	17.33	16.8	17.33	17.33	17.58	0.25	1.4%

The Finance Department is also responsible for two other City funds: the Equipment Replacement Fund and the Unemployment Fund. The fund breakdown is displayed below.

Expenditures By Fund	2006 Current					2006 Current	Percentage Change
	2004 Actual	2005 Actual	Budget	2006 Projected	2007 Budget	Budget versus 2007 Budget	
General Fund	\$2,905,074	\$2,921,631	\$3,937,648	\$3,385,228	\$3,810,526	-\$127,122	(3.23%)
Equipment Replacement Fund	\$126,093	\$223,907	\$138,180	\$118,000	\$100,000	-\$38,180	(27.63%)
Unemployment Fund	\$37,743	\$15,425	\$10,000	\$30,000	\$10,000	\$0	0.00%
Total Fund Expenditures	\$3,068,910	\$3,160,963	\$4,085,828	\$3,533,228	\$3,920,526	-\$165,302	(4.05%)
Revenue By Fund							
General Fund	\$1,800	\$2,093	\$1,800	\$8,167	\$6,800	\$5,000	277.78%
Equipment Replacement Fund	\$298,927	\$307,148	\$299,308	\$336,810	\$315,569	\$16,261	5.43%
Unemployment Fund	\$42,767	\$13,229	\$10,450	\$32,300	\$10,500	\$50	0.48%
Total Fund Revenue	\$343,494	\$322,470	\$311,558	\$377,277	\$332,869	\$21,311	6.84%

2007 Budget Highlights

- The Finance Technician in the Financial Planning and Accounting Services programs has been increased from 0.50 FTE to 0.625 FTE and the Finance Technician in the Purchasing Services program has been increased from 0.625 FTE to 0.75 FTE. This is an addition of 520 hours of service for 2007. The changes have been funded by reductions in professional services in the Financial Planning and Accounting Services program and advertising in the Purchasing program.
- The 2006 budget for the Information Technology Strategic Plan included \$28,250 in carry-over expenditures from 2005. This amount is not included in the 2007 budget.



Finance 2007 Budget

- State audit costs are projected to increase by \$1,395. This increase is included in the intergovernmental services line-item in the Financial Planning and Accounting Services program.
- The Finance Department level of service for janitorial services was increased in 2006. The additional cost of \$3,559 has been added to professional services in the Financial Planning and Accounting Services program.
- Telephone service costs have continued to increase as the City's service providers for land lines (Verizon) and cellular phones (Nextel) increase rates. Telephone costs will increase by \$49,404 for 2007 when compared to the 2006 budget. Total telephone related costs for 2006 are projected to be \$253,000 for 2006 and \$267,404 for 2007. The 2006 budget was \$218,000. Telephone costs are in the services and charges line item within the Information Technology Operations and Security program.
- The 2006 budget included \$246,663 in contingency. The majority of this contingency (\$180,000) was for future increases in the employer contribution to the Washington State Public Employees Retirement System (PERS). These rate increases are occurring in 2007 and therefore have been programmed in all City department's personnel costs. The remaining portion of the contingency was for possible lease cost increases and impacts from the 2005 salary survey. The 2007 budget has \$93,465 budgeted as a contingency. \$30,000 of this contingency is to fund the increased costs related to the 2006 salary survey and the remaining \$63,465 is being reserved to apply towards possible increases in street light rates or further increases in the PERS contribution rate.
- The City's liability assessment is budgeted in charges line-item within the non-program city-wide budget. The City's liability insurance assessment is increasing by \$50,842 from 2006 to 2007.
- The 2006 non-program City-wide budget included \$99,000 for the 2006 bond election. This was considered a one-time expense and therefore was not included in the 2007 budget. This was an intergovernmental service.
- The 2006 non-program City-wide budget included \$64,468 to replace 11 copiers throughout the City. This item was budgeted in capital outlay in 2006.

FINANCIAL PLANNING AND ACCOUNTING SERVICES

PROGRAM PURPOSE:

This program provides financial analysis, financial reporting, accounting services, and financial planning to support City departments making fiscal and organizational decisions resulting in the optimization of city resources.

STRATEGIC OBJECTIVES:

Economic Vitality and Financial Stability

Measurement: EFFECTIVENESS	2004	2005	2006	2007/Target
Actual revenue collections compared to projected revenues.	101%	104.1%	95-105%	
Basis points in which investment returns exceed the City's benchmark	9	75	22	
Percentage of customers rating the Budget Division services as good or excellent	100%	100%	98%	
Percentage of customers rating the Finance Department services as good or excellent	98.7%	98.7%	92%	
Percentage of customers rating the Financial Operations Division services as good or excellent	97.8%	97.8%	94%	
Percentage of internal customers rating Finance Operations overall services as good or excellent			96%	
Percentage of time month-end close process completed within 10 working days of the end of the month	58%	50%	92%	

Measurement: EFFICIENCY	2004	2005	2006	2007/Target
Financial planning and accounting services as a % of the City's operating budget.	2.5%	2.6%	N/A	
Number of accounts payable checks processed per dedicated FTES.	4,088	4,042		
Number of payroll checks processed per dedicated FTES.	5,731	5,934		

FINANCIAL PLANNING AND ACCOUNTING SERVICES

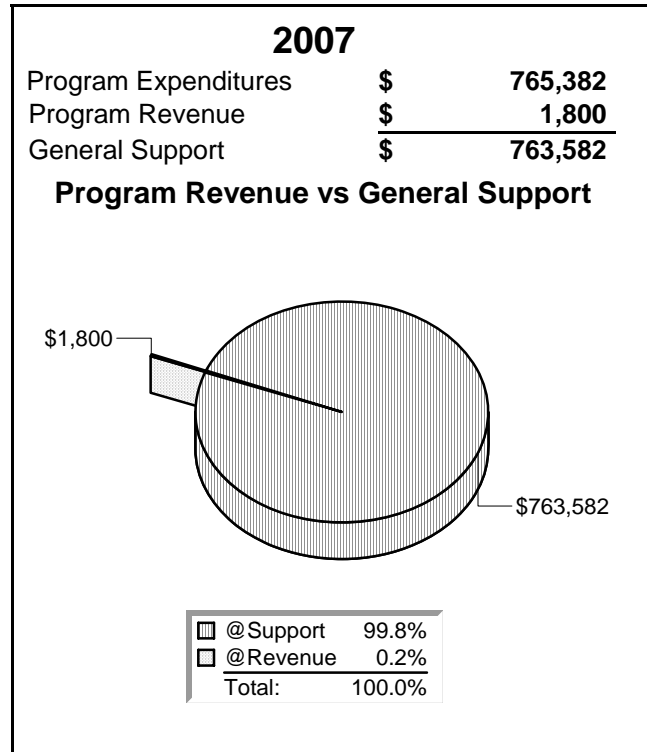
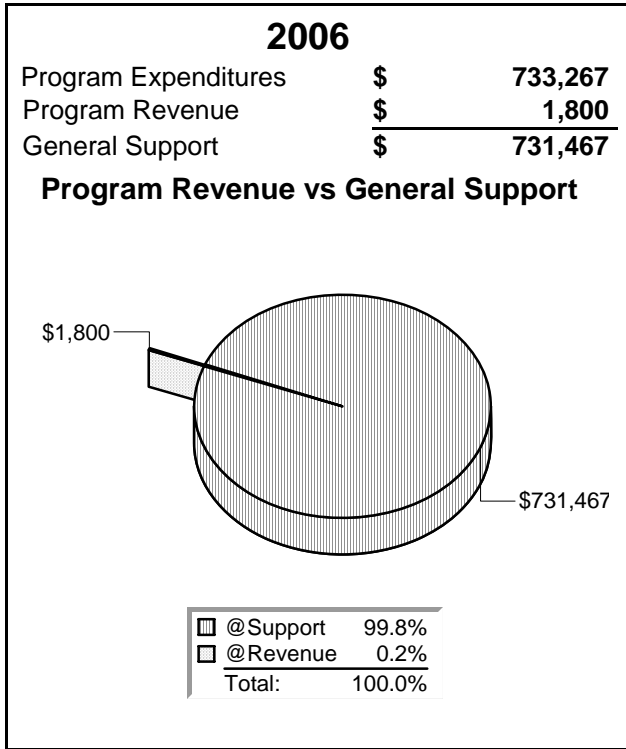

PURCHASING SERVICES

PROGRAM PURPOSE:

Purchasing provides City departments with knowledge and resources to obtain goods and services for the best value, while complying with applicable Federal, State, and City procurement regulations

STRATEGIC OBJECTIVES:

Governmental Excellence

Measurement: EFFECTIVENESS	2004	2005	2006	2007/Target
Number of protests filed per \$25 million purchased	0	0	0	
Percentage of awards and solicitations made without protest	100%	97%	100%	
Percentage of customers rating the Purchasing Division services as good or excellent	89%	89%	88%	
Percentage of internal customers rating the Purchasing Division timeliness of services as good or excellent	89%	89%	88%	

Measurement: EFFICIENCY	2004	2005	2006	2007/Target
Dollar Amount of Central Purchasing Office Purchases per Central Purchasing Office FTE	\$9.041M	\$14.8M		
Number of Purchasing transactions per FTE.	456	385	N/A	
Percentage of purchasing transactions conducted using procurement and credit cards	1.18%	2.27%	2.0%	

Measurement: OTHER	2004	2005	2006	2007/Target
Number of protests filed and sustained	0	0	0	

PURCHASING SERVICES

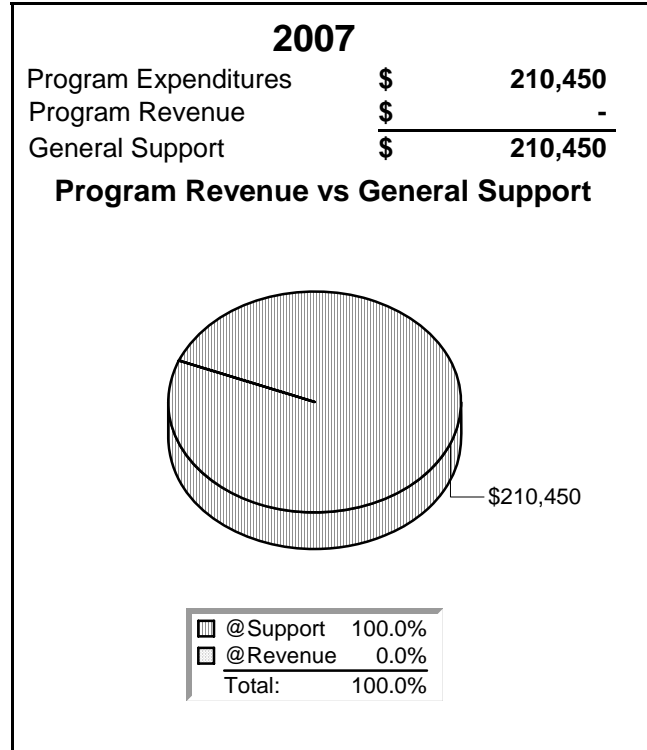
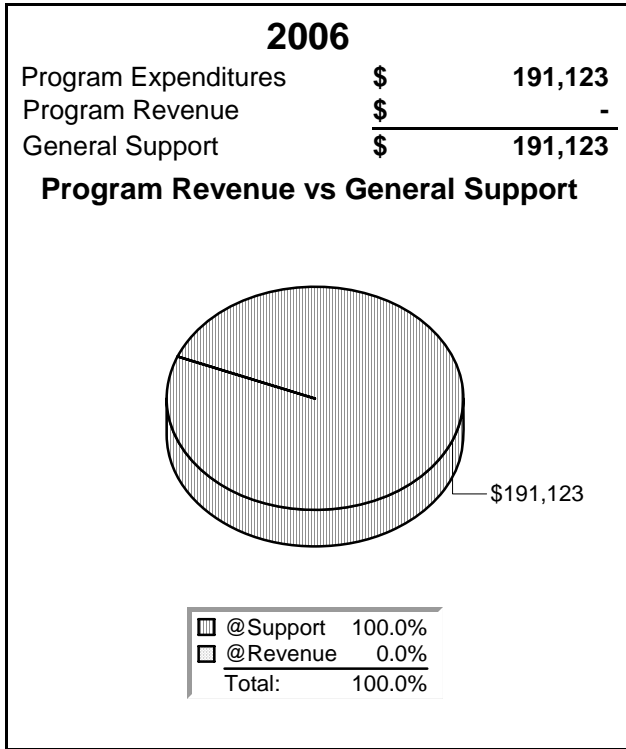

GEOGRAPHICAL INFORMATION SYSTEMS

PROGRAM PURPOSE:

Geographical Information Systems manages enterprise wide data so that it is readily available to City departments to support their decision-making and planning processes.

STRATEGIC OBJECTIVES:

Quality Services, Facilities and Infrastructure

Measurement: EFFECTIVENESS	2004	2005	2006	2007/Target
Percentage of customers rating the GIS services as good or excellent			98%	
Percentage of internal customers rating GIS overall services as good or excellent			98%	

Measurement: EFFICIENCY	2004	2005	2006	2007/Target
Number of Service Requests completed per FTE	154	126	N/A	

Measurement: WORKLOAD	2004	2005	2006	2007/Target
Number of Service Requests	154	126	N/A	

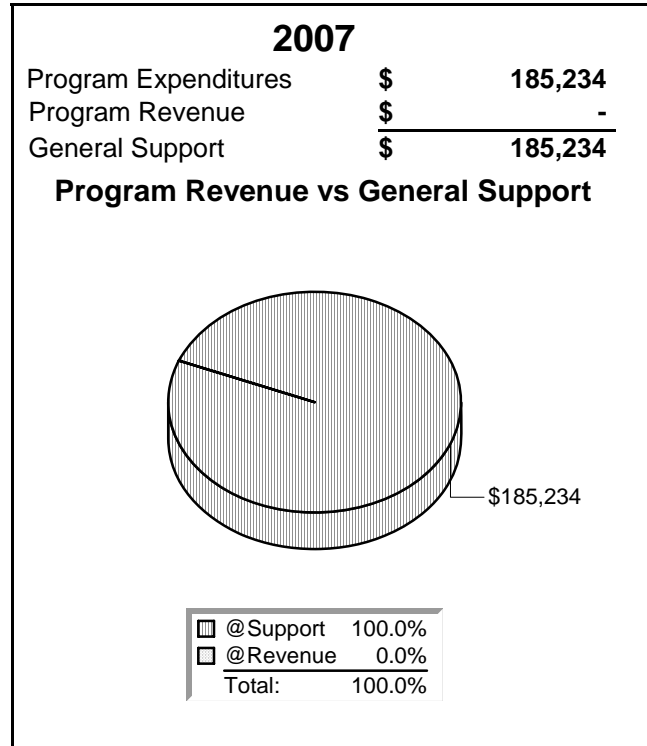
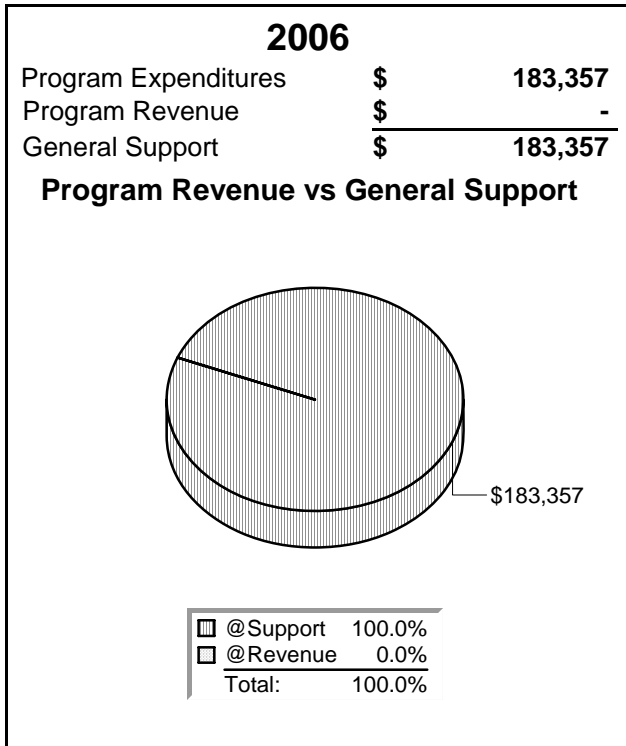

INFORMATION TECHNOLOGY OPERATIONS AND SECURITY ADMINISTRATION

PROGRAM PURPOSE:

IT Operations and Security Administration provides technology infrastructure that supports the daily operations of City departments in achieving their goals and objectives.

STRATEGIC OBJECTIVES:

Quality Services, Facilities and Infrastructure

Measurement: EFFECTIVENESS	2004	2005	2006	2007/Target
Help Desk calls resolved within 8 hours		63%	65%	
Percentage of customers rating the Information Technology Division services as good or excellent	93%	93%	88%	
Percentage of help desk calls resolved and/or repaired within 24 hours	92%	98.5%	95%	
Percentage of Help Desk calls resolved at time of call		32%	33%	
Percentage of Help Desk calls resolved within 4 hours		54%	55%	
Percentage of telephone system problems resolved within 24 hours		73%	70%	

Measurement: EFFICIENCY	2004	2005	2006	2007/Target
Central information technology operating maintenance and capital expenditures per workstation.	\$6,383	\$6,065	N/A	
Central IT operating & maintenance expenditures per workstation (excluding telephone service)	\$4,061	\$3,044	N/A	
Information technology operating and maintenance expenditures as a percentage of the City's operating budget	3.5%	3.6%	N/A	
Number of workstations per Central IT FTE	36.42	36.42	33	

INFORMATION TECHNOLOGY OPERATIONS AND SECURITY ADMINISTRATION

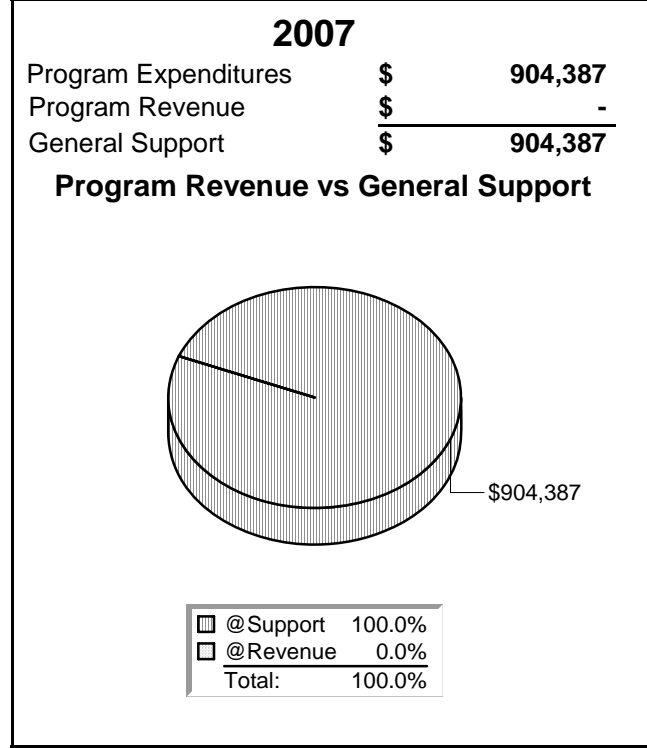
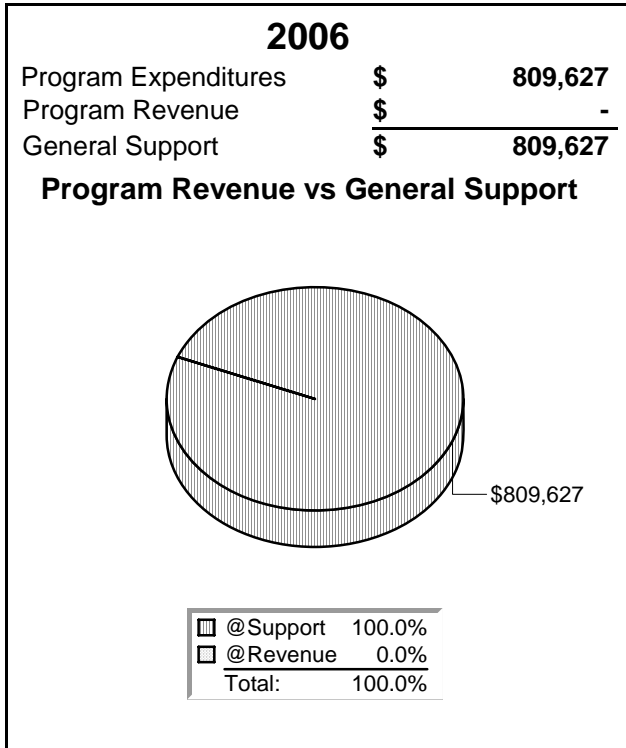

INFORMATION TECHNOLOGY STRATEGIC PLAN IMPLEMENTATION

PROGRAM PURPOSE:

Information Technology Strategic Plan Implementation provides needs assessment, justification, alternatives analysis, oversight, project management, and on-site consultation advisory services to City departments/staff to successfully deliver projects in the City's IT Strategic Plan, aimed at enhancing service levels and streamlining business processes through the utilization of technology.

STRATEGIC OBJECTIVES:

Governmental Excellence

Measurement: EFFICIENCY	2004	2005	2006	2007/Target
Information Technology Strategic Plan expenditures as a percentage of the City's operating budget	2.3%	1.8%	N/A	

Measurement: OTHER	2004	2005	2006	2007/Target
Total capital expenditures for IT activities and equipment	\$441,210	\$479,039	N/A	

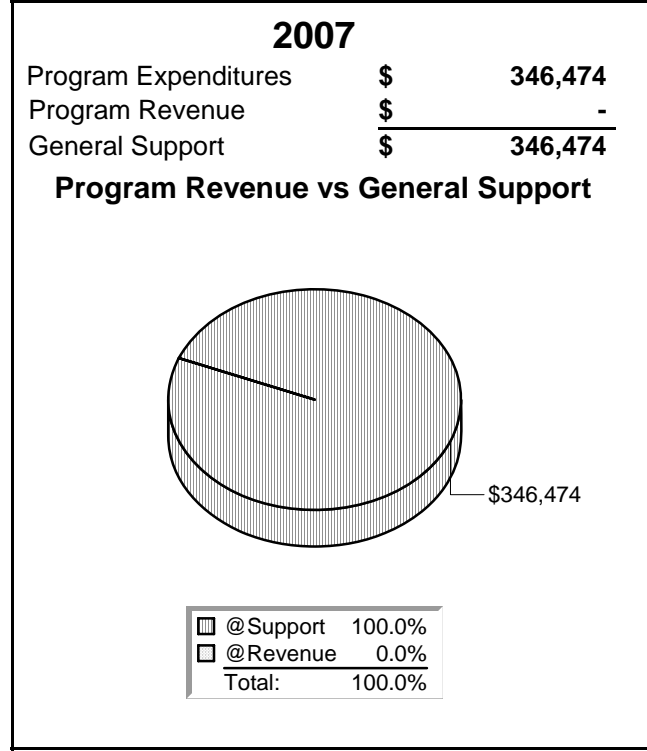
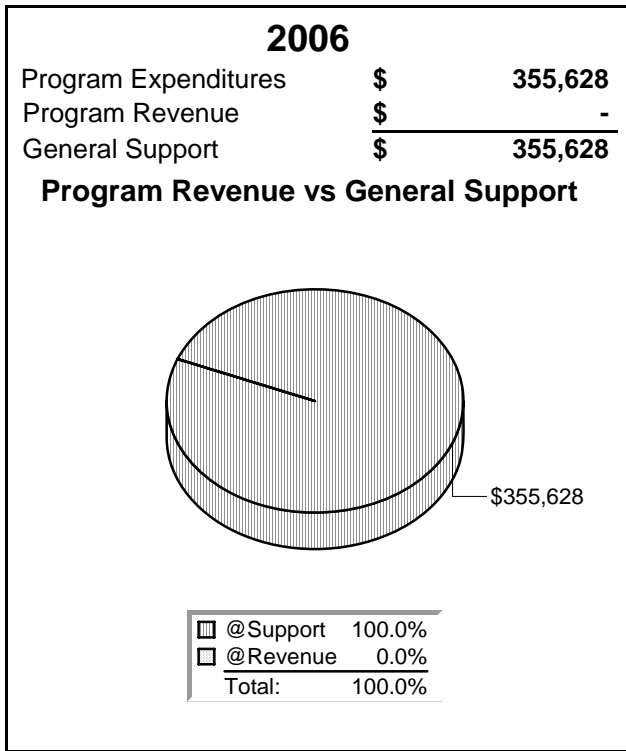

GRANT RESEARCH & DEVELOPMENT

PROGRAM PURPOSE:

The Grant Development program coordinates and supports all City Departmental grant seeking efforts designed to increase resources available for General Fund and Capital Improvement Program Budgets

STRATEGIC OBJECTIVES:

Economic Vitality and Financial Stability

Measurement: EFFECTIVENESS	2004	2005	2006	2007/Target
Percentage of customers rating the Grant Development services as good or excellent	100%	100%	92%	
Percentage of grant applications successfully awarded	64%	60%	77%	
Percentage of internal customers rating Grant Assistance overall services as good or excellent			92%	

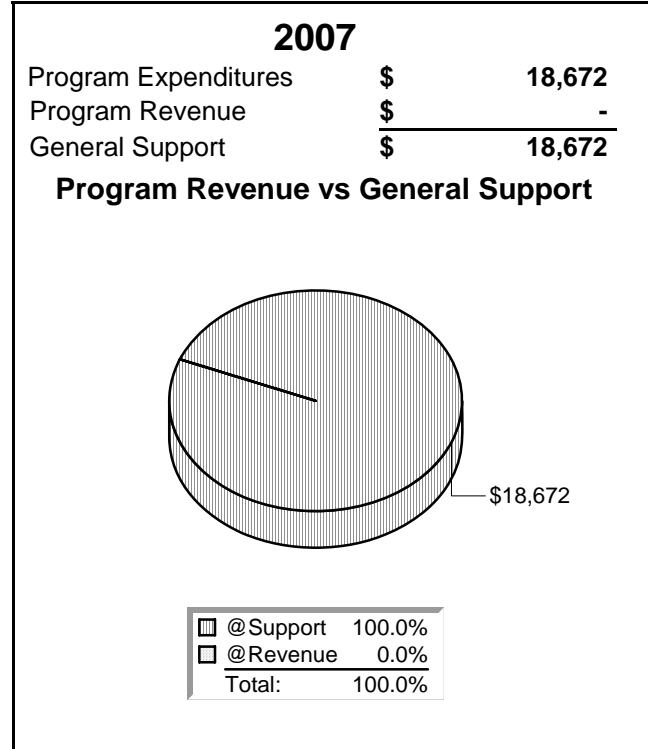
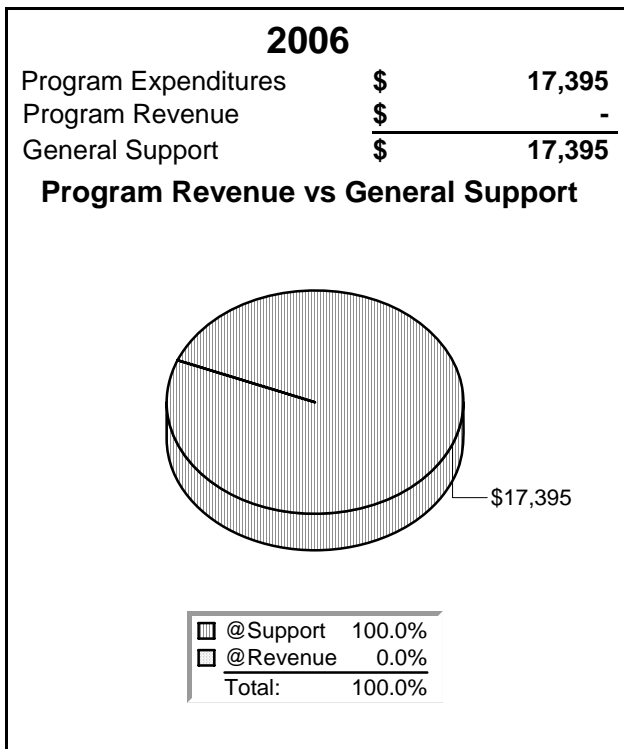

INTERGOVERNMENTAL PARTICIPATION

PROGRAM PURPOSE:

City participation in organizations that provide a forum for city staff and/or council members to address federal, state, and regional issues and that provide financial or legislative support to the City. Includes the following organizations: Seashore Transportation Forum, Suburban Cities, Association of Washington Cities, Economic Development Council of Seattle & King County, National League of Cities, Puget Sound Regional Council, Puget Sound Clean Air Agency, and the Shoreline Chamber of Commerce.

STRATEGIC OBJECTIVES:

Governmental Excellence

Measurement: EFFICIENCY	2004	2005	2006	2007/Target
Program expenditures as a percentage of the City's total operating budget	0.37%	0.36%	0.40%	

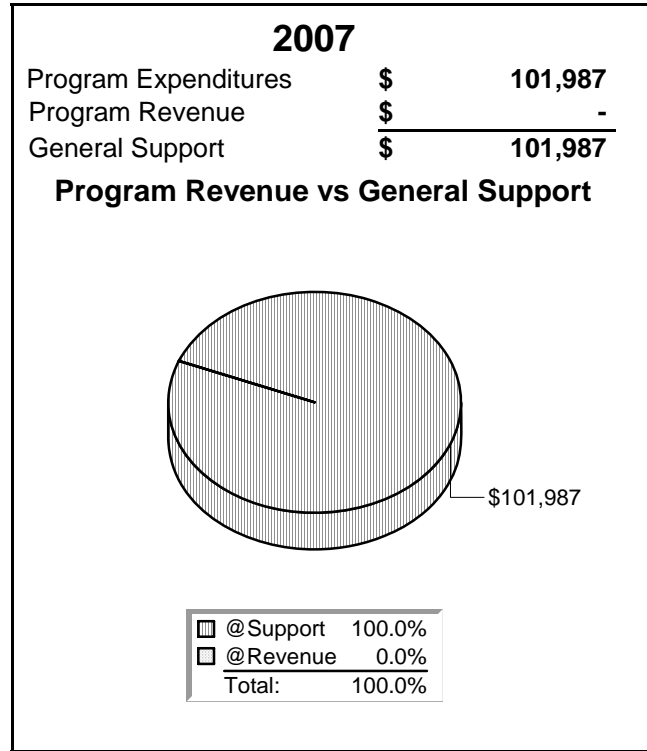
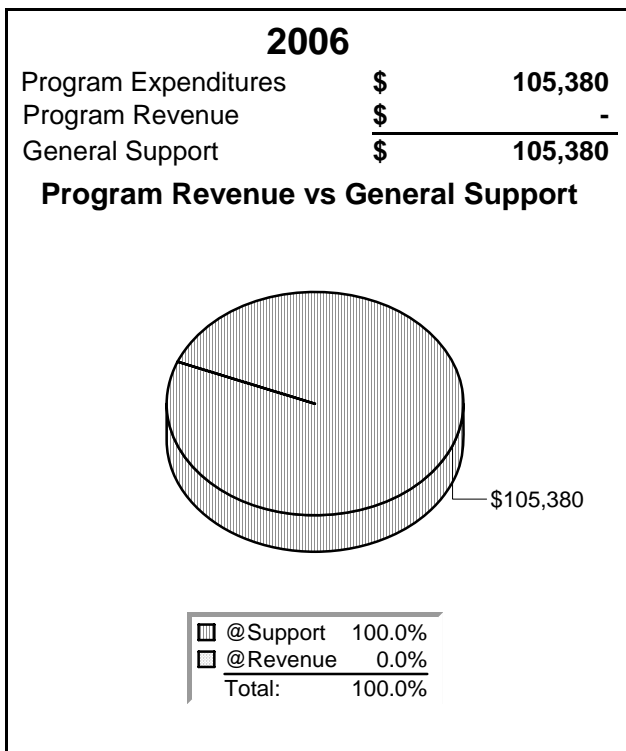



This Page Has Been Intentionally Left Blank



Human Resources



Human Resources 2007 Budget

Mission Statement

The mission of Human Resources is to foster and support our organizational values and goals to attract, retain and develop a professional and committed workforce that provides the highest quality and value in customer service

Department Programs

Employment Recruitment and Compensation Administration

3.0 FTE

2007 Human Resources as a Share of the General Fund

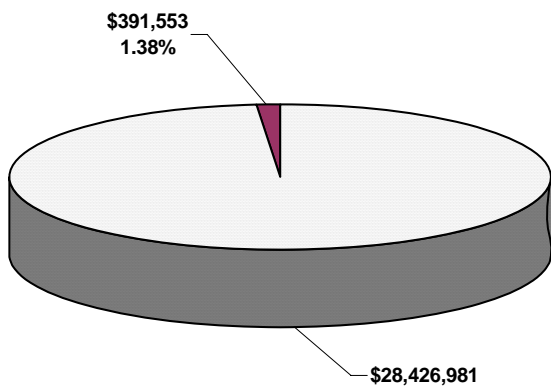

Human Resources
Historical Comparison
2004 - 2007

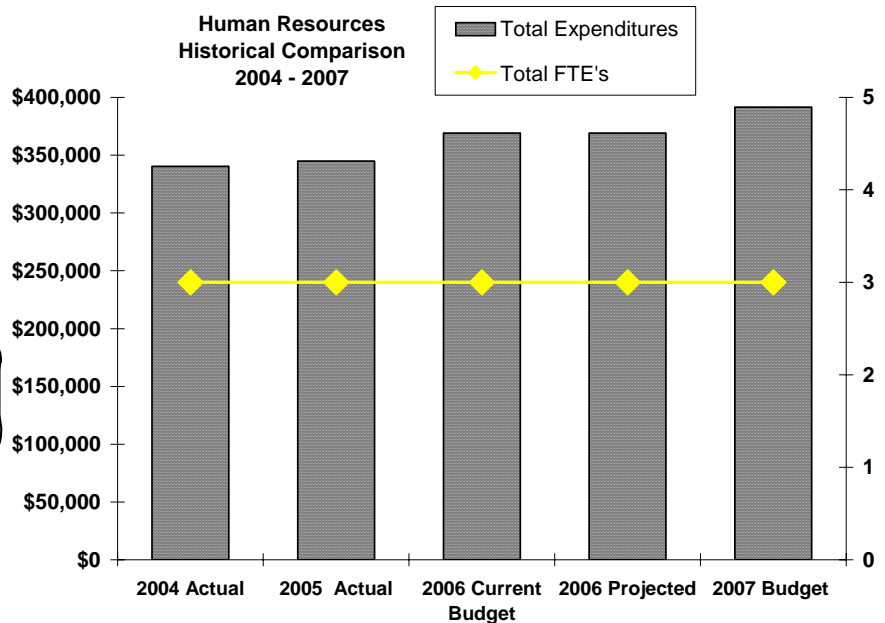



Human Resources 2007 Budget

2006 Key Department Accomplishments in Support of the City's Strategic Objectives:

Governmental Excellence

- Participated in the 2006 Internal Customer Service Survey and incorporated the results into the Human Resources work plan.
- Conducted refresher and advanced communication training.
- Developed and implemented 2006 Supervisory Training Program.
- Developed and implemented the Vehicle Use Policy.
- Developed and implemented the Blood borne Pathogen Program.
- Formed an ad-hoc committee to evaluate and improve the Employee Recognition Program.
- Created an ongoing employee tracking system to coordinate certifications, licensing, training and recruiting information.

2007 Key Department Objectives in Support of the City's Strategic Objectives:

Governmental Excellence

- Professional Development for Managers: design and implement a program that makes training and tools available for successful leadership and management.
- Develop and implement action plan based on Internal Customer Service Survey results.
- Continue to find new ways of fostering the city's adopted communications model throughout the organization via the Ambassador Team.
- Assist the Office of Communications and Intergovernmental Relations in implementing the citywide Volunteer Program.
- Implement updated employee recognition program.
- Continue to expand employee communication training.



Human Resources 2007 Budget

Human Resources 2004 - 2007 Budget Comparison By Program							
Program Budget	2004 Actual	2005 Actual	2006 Current Budget	2006 Projected	2007 Budget	2006 Current Budget versus 2007 Budget	Percentage Change
Employment Recruitment and Compensation Administration	\$340,294	\$344,954	\$369,222	\$369,222	\$391,553	\$22,331	6.05%
Total Program Budget	\$340,294	\$344,954	\$369,222	\$369,222	\$391,553	\$22,331	6.05%
Program Revenue							
Other Revenue	\$2,545	\$418	\$1,000	\$2,031	\$1,500	\$500	0.00%
General Fund Subsidy	\$337,749	\$344,536	\$368,222	\$367,191	\$390,053	\$21,831	5.93%
Total Resources	\$340,294	\$344,954	\$369,222	\$369,222	\$391,553	\$22,331	6.05%
Department Statistics							
Total FTE's	2.50	3.00	3.00	3.00	3.00	0	0.00%

Human Resources 2004 - 2007 Budget Comparison By Object							
Object Category	2004 Actual	2005 Actual	2006 Current Budget	2006 Projected	2007 Budget	2006 Current Budget versus 2007 Budget	Percent Change
Salaries	\$195,409	\$192,967	\$204,589	\$204,841	\$216,012	\$11,423	5.58%
Personnel Benefits	\$44,573	\$43,951	\$50,387	\$50,404	\$58,545	\$8,158	16.19%
Supplies	\$8,769	\$7,013	\$9,150	\$8,881	\$11,900	\$2,750	30.05%
Other Services & Charges	\$91,543	\$101,013	\$105,096	\$105,096	\$105,096	\$0	0.00%
Intergovernmental Services	\$0	\$10	\$0	\$0	\$0	\$0	0.00%
Capital Outlays	\$0	\$0	\$0	\$0	\$0	\$0	0.00%
Interfund Payments for Service	\$0	\$0	\$0	\$0	\$0	\$0	0.00%
Total Expenditures	\$340,294	\$344,954	\$369,222	\$369,222	\$391,553	\$22,331	6.05%
Revenue							
Other Revenue	\$2,545	\$418	\$1,000	\$2,031	\$1,500	\$500	50.00%
General Fund Subsidy	\$337,749	\$344,536	\$368,222	\$367,191	\$390,053	\$21,831	5.93%
Total Resources	\$340,294	\$344,954	\$369,222	\$369,222	\$391,553	\$22,331	6.05%
Department Statistics							
Total FTE's	3.00	3.00	3.00	3.00	3.00	0	0.00%
% of General Fund	1.41%	1.17%	1.26%	1.26%	1.38%	0.12%	9.67%

2007 Key Department Highlights

- The 2007 Budget for operating supplies has been increased by \$2,750. This is to provide the adequate funding for the City's employee recognition program. One change from previous years is that the City now recognizes tenure for 10 year employees as well as 5 year employees. 2006 was the first year that the City had employees who had worked for the City for this length of time.

EMPLOYEE RECRUITMENT, COMPENSATION ADMINISTRATION & ORGANIZATIONAL DEVELOPMENT

PROGRAM PURPOSE:

This program creates an environment which attracts, retains and develops a professional and committed workforce to support delivery of the highest quality public services to Shoreline residents.

STRATEGIC OBJECTIVES:

Governmental Excellence

Measurement: EFFECTIVENESS	2004	2005	2006	2007/Target
Benefits as a percentage of Salaries & Benefits	20.7%	21.2%	21.2%	
Percentage of customers rating Human Resources services as good or excellent	92%	92%	87%	95%
Percentage of employees who feel personally responsible to provide quality customer service	96%	96%	96%	96%
Percentage of employees who rate the City of Shoreline as one of the best organizations to work for compared to other organizations	64%	73.2%	75%	76%
Percentage of regular staff who terminated employment during the year	6%	15%	8%	
Salary and Benefits as a Percent of the Operating Budget	30%	35.9%	33.19%	

Measurement: EFFICIENCY	2004	2005	2006	2007/Target
Average number of working days for external recruitment	N/A	58	56	53
Human resource budget as a percent of the operating budget	1.4%	1.4%	1.04%	
Ratio of human resources FTE's to total benefitted FTE's	1:45.8	1:46.6	1:48.4	

EMPLOYEE RECRUITMENT, COMPENSATION ADMINISTRATION & ORGANIZATIONAL DEVELOPMENT

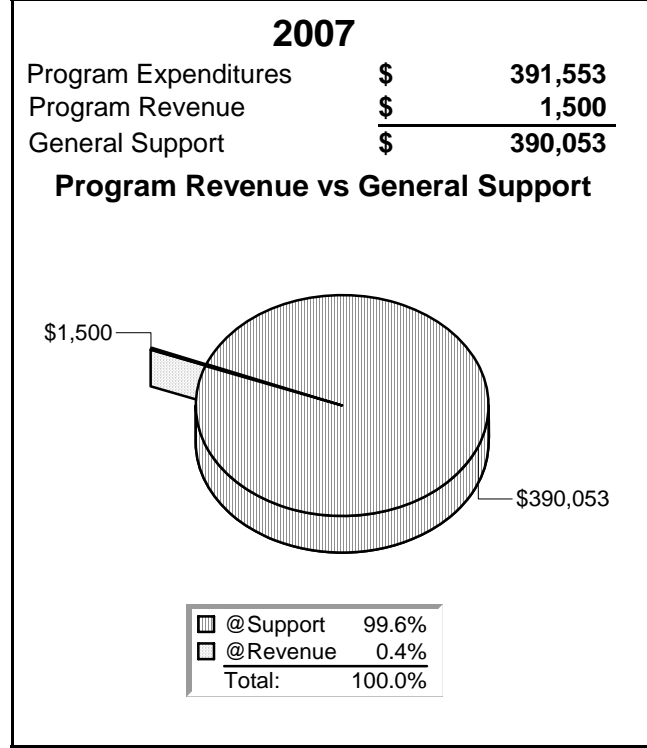
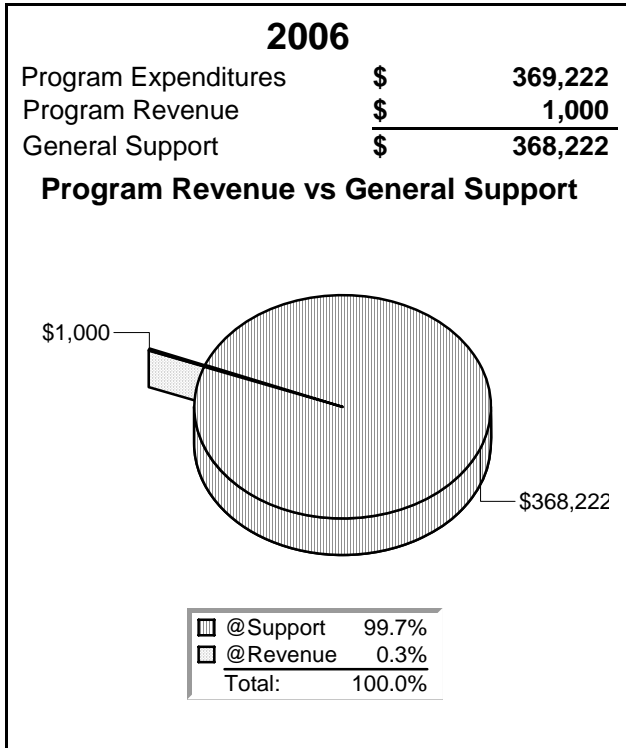



This Page Has Been Intentionally Left Blank



Customer Response Team



Customer Response Team 2007 Budget

Mission Statement

"The mission of the Customer Response Team is to respond to internal and external inquiries, concerns, suggestions and complaints and provide reliable resolution and follow up to guarantee customer satisfaction."

Department Programs

24 Hour Customer Response Team

1.75 FTE

Code Enforcement Team

3.25 FTE

2007 Customer Response Team as a Share of the General Fund

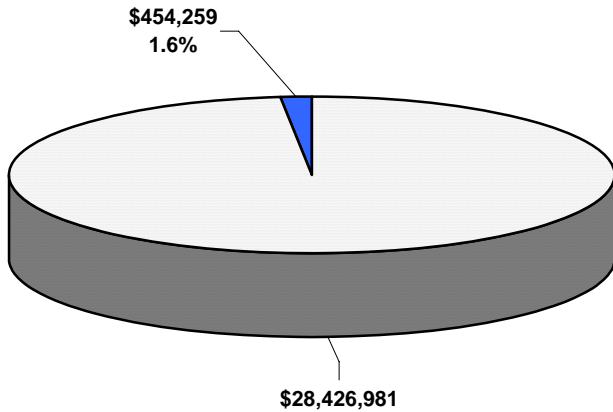

CRT Historical Comparison

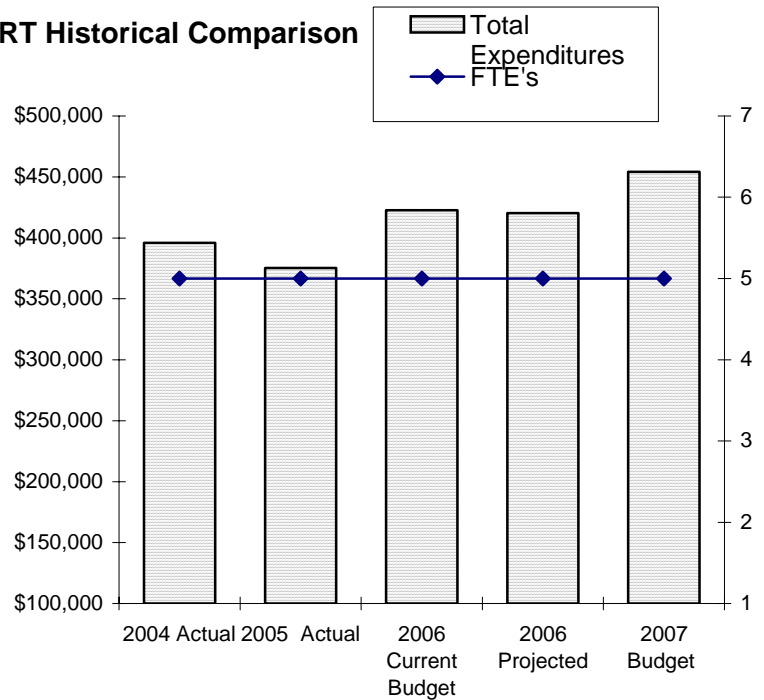



Customer Response Team 2007 Budget

2006 Key Department Accomplishments in Support of the City's Strategic Objectives:

Safe and Attractive Neighborhoods and Business Districts

- Provided liaisons for neighborhood activities, including representation at meetings, and assistance in responding to community issues as well as ongoing support and assistance to: the recycling program, the North City annual holiday event, and all neighborhood association mini grants and Celebrate Shoreline
- Provided ongoing inter-departmental participation and assistance to the Code Enforcement Program, Emergency Operations and emergency response to the Police and Fire Departments, and for abandoned vehicles in the right-of-way, in addition to special projects.

Quality Services, Facilities and Infrastructure

- Collected and analyzed customer request data to identify small drainage construction projects, improvements to pedestrian pathways, overlay areas, ADA improvements, upgrades, and the need for additional preventative maintenance programs in support of Public Works.
- Responded to approximately 5,000 customer requests and answered over 25,000 telephone calls.
- Continued strong performance in 24-hour accessibility.

Governmental Excellence

- Provided operating departments with management reports detailing customer service requests.



Customer Response Team 2007 Budget

2007 Key Department Objectives in Support of the City's Strategic Objectives:

CRT's primary responsibility remains addressing customer concerns in a timely manner. In 2007, CRT will address the following aspects of customer service:

Safe and Attractive Neighborhoods and Business Districts

- Continuing efforts to develop new initiatives to assist departments with areas of concern to citizens (like the Abandoned Vehicle Program, the Utility Tax Relief Program, and the Pedestrian Pathway Improvement Program), and
- In addition to all Strike One code enforcement actions CRT will process Strike Two code enforcement actions.

Quality Services, Facilities and Infrastructure

- Moving CRT into a business partnership role focused on service delivery

Governmental Excellence

- Simplifying and standardizing CRT policies and procedures
- Keep customer focus at the heart of CRT



Customer Response Team 2007 Budget

Customer Response Team 2004 - 2007 Budget Comparison By Program							
Program Expenditures	2004 Actual	2005 Actual	2006 Current Budget	2006 Projected	2007 Budget	2006 Current Budget versus 2007 Budget	Percentage Change
24 Hour Customer Service	\$281,077	\$266,325	\$139,514	\$138,689	\$158,991	\$19,477	13.96%
Code Enforcement Team*	\$95,012	\$90,025	\$283,255	\$281,580	\$295,268	\$12,013	4.24%
Traffic Services & NTSP**	\$19,794	\$18,755	\$0	\$0	\$0	\$0	NA
Total Expenditures	\$395,883	\$375,106	\$422,769	\$420,269	\$454,259	\$31,490	7.45%
* Code Enforcement Team includes CRT and Code Enforcement which is budgeted in the Planning & Development Services Department							
**NTSP is a program supported by CRT, Police, and Traffic Services which is budgeted in the Public Works Department							
Program Revenue							
Other Revenue	\$41	\$0	\$0	\$0	\$0	\$0	0.00%
General Fund Subsidy	\$395,842	\$375,106	\$422,769	\$420,269	\$454,259	\$31,490	7.45%
Total Resources	\$395,883	\$375,106	\$422,769	\$420,269	\$454,259	\$31,490	7.45%
Department Statistics							
FTE's	5	5	5	5	5	0	0.00%

* Total program costs for Code Enforcement are \$465,790 for 2007. The remaining \$170,522 is in the Planning and Development Services department.

** The Customer Response Team is no longer providing direct support to the Neighborhood Traffic Safety Program. This is included for historical comparison only.

2007 CRT Program Breakdown

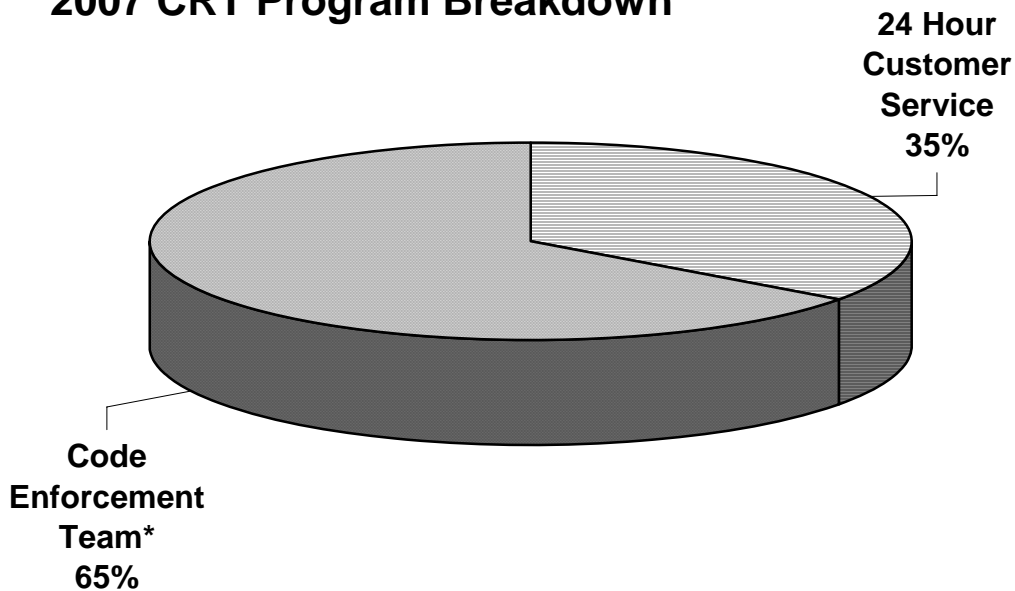



Customer Response Team 2007 Budget

Customer Response Team 2004 - 2007 Budget Comparison By Object							
Object Category	2004 Actual	2005 Actual	2006 Current Budget	2006 Projected	2007 Budget	2006 Current Budget versus 2007 Budget	Percentage Change
Salaries	\$291,882	\$266,244	\$305,395	\$306,780	\$318,810	\$13,415	4.39%
Benefits	\$81,122	\$77,522	\$87,930	\$87,930	\$106,117	\$18,187	20.68%
Supplies	\$4,247	\$5,794	\$5,558	\$4,658	\$5,558	\$0	0.00%
Other Services & Charges	\$3,720	\$16,049	\$11,400	\$8,400	\$10,100	-\$1,300	-11.40%
Intergovernmental Services	\$0	\$0	\$0	\$15	\$0	\$0	0.00%
Capital Outlays	\$0	\$0	\$0	\$0	\$0	\$0	0.00%
Interfund Payments for Service	\$14,912	\$9,497	\$12,486	\$12,486	\$13,674	\$1,188	9.51%
Total Expenditures	\$395,883	\$375,106	\$422,769	\$420,269	\$454,259	\$31,490	7.45%
Revenue							
Other Revenue	\$41	\$0	\$0	\$0	\$0	\$0	0.00%
General Fund Subsidy	\$395,842	\$375,106	\$422,769	\$420,269	\$454,259	\$31,490	7.45%
Total Resources	\$395,883	\$375,106	\$422,769	\$420,269	\$454,259	\$31,490	7.45%
Department Statistics							
FTE's	5	5	5	5	5	0	0.00%
% of General Fund	1.64%	1.27%	1.44%	1.43%	1.60%	0.16%	11.12%

2007 Budget Highlights

- The 2007 Budget for Professional Services was reduced by \$1,300 when compared to prior years. These monies were budgeted for additional staff development and training sessions.
- The 2007 Budget for Vehicle Operations and Maintenance was increased by \$1,188 to cover additional repairs and maintenance.

24 HOUR CUSTOMER RESPONSE TEAM

PROGRAM PURPOSE:

Responds to internal and external inquiries, concerns, suggestions and complaints and provide reliable resolution and follow up to guarantee customer satisfaction. Provide telephone and in-person problem resolution and follow-up.

STRATEGIC OBJECTIVES:

Quality Services, Facilities and Infrastructure

Measurement: EFFECTIVENESS	2004	2005	2006	2007/Target
Percentage of customer requests responded to within 24 hours	97%	95%	97%	95%
Percentage of customers giving CRT services a good or excellent rating	94%	98%	98%	95%
Percentage of internal customers rating CRT overall services as good or excellent			90%	
Percentage of requests inspected within 5 working days.	97%	99%	99%	95%

Measurement: EFFICIENCY	2004	2005	2006	2007/Target
Average Cost per Service Request	N/A	\$69	\$33	
Average Number of Service Requests per FTE	867	854	931	

Measurement: WORKLOAD	2004	2005	2006	2007/Target
Number of customer requests for service	3,079	4,272	4165	3839
Number of Service Requests for Litter/Garbage.		209	310	
Number of Service Requests for Parking/Abandoned Vehicles.		1,626	1236	
Number of Service Requests for Signs.		328	350	
Number of Service Requests for Vegetation.		228	128	
Number of Service Requests for Zoning Code Violations.		321	334	

24 HOUR CUSTOMER RESPONSE TEAM

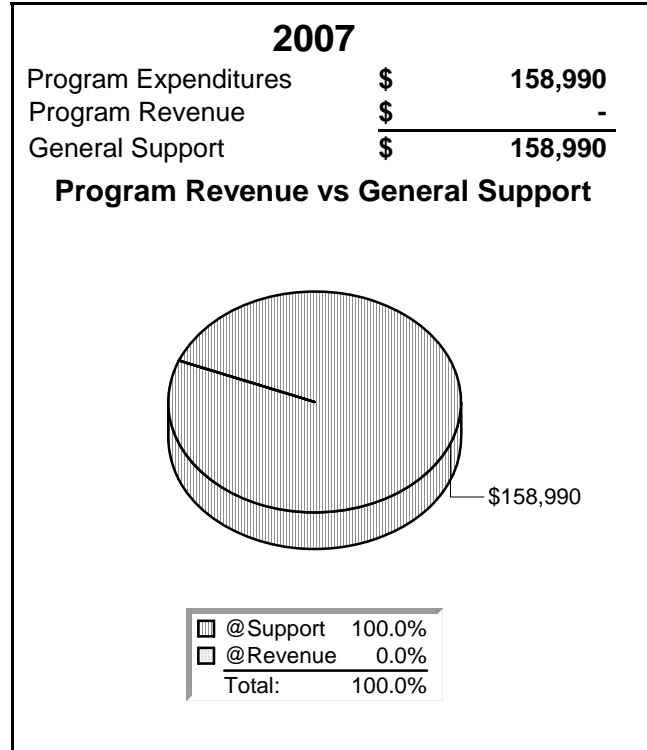
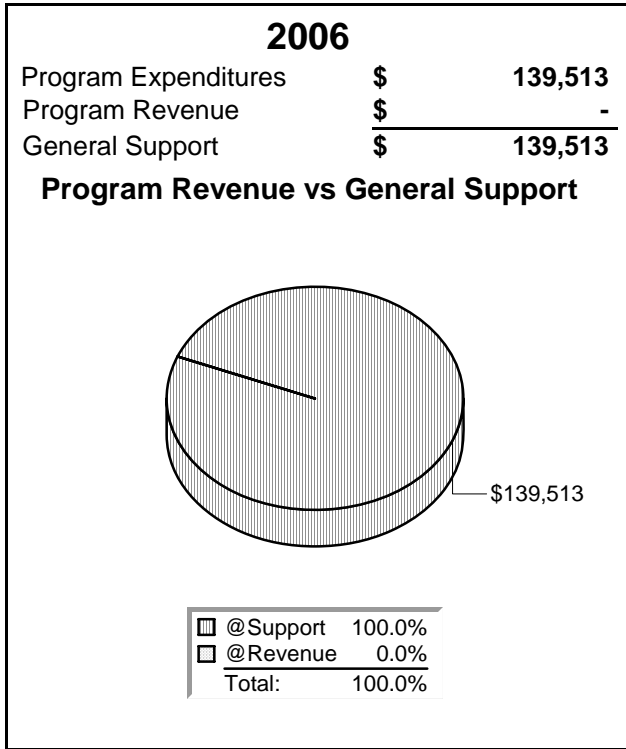

CODE ENFORCEMENT TEAM

PROGRAM PURPOSE:

The Code Enforcement Team enforces the City's codes and regulations to implement community values and to sustain a safe and attractive City.

STRATEGIC OBJECTIVES:

Safe and Attractive Neighborhoods and Business Districts

Measurement: EFFECTIVENESS	2004	2005	2006	2007/Target
Average number of calendar days from request initiation to voluntary compliance (Strike I)		12	5	15
Percent of abandoned vehicles tagged within 24 hours of notification	N/A	99%	98%	95%
Percentage of all cases issued a Notice and Order that are brought into compliance annually.	45%	31%	30%	38%
Percentage of all code enforcement actions resolved by voluntary compliance (Strike I)	92.7%	92%	98%	85%
Percentage of cases closed by induced compliance (Strike 2 & 3) annually	29%	30%	30%	30%
Percentage of cases open beyond 365 days (Strike 2&3)	70%	72%	70%	70%
Percentage of internal customers rating Code Enforcement overall services as good or excellent			91%	

Measurement: EFFICIENCY	2004	2005	2006	2007/Target
Code Enforcement expenditures per capita	\$2.47	\$2.70	\$2.90	\$2.90
Number of Active Cases per FTE	89	96	105	75
Number of code enforcement actions (Strike I) per FTE	219	976	494	500

Measurement: WORKLOAD	2004	2005	2006	2007/Target
Number of Code Enforcement requests for action	472	1,997	1,694	N/A
Total Number of Code Enforcement actions resolved (Strike I)	438	1,900	1,622	N/A

CODE ENFORCEMENT TEAM

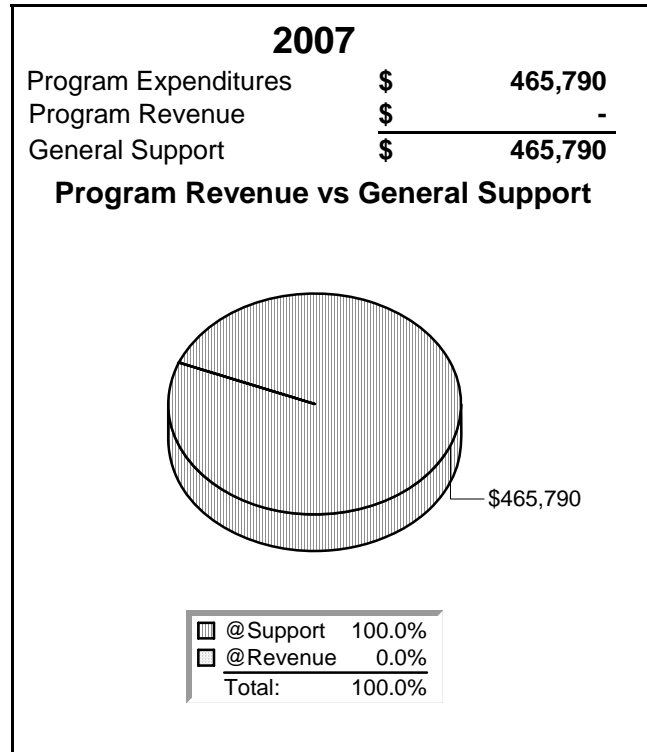
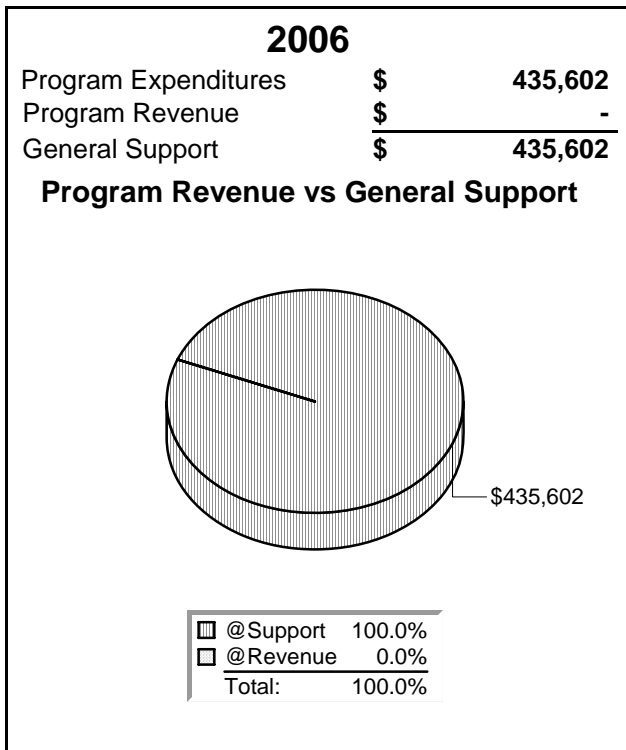



This Page Has Been Intentionally Left Blank



Police



Police 2007 Budget

Mission Statement

“The mission of the Shoreline Police Department is to prevent crime and create an environment where people feel safe, while providing quality, professional law enforcement services designed to improve public safety.”

Department Programs

Administration

1.0 FTE
5.0 Contract FTE

Patrol

0.0 FTE
28.0 Contract FTE

Investigations Crimes Analysis

0.0 FTE
4.0 Contract FTE

Street Crimes Investigations

0.0 FTE
3.0 Contract FTE

Traffic Enforcement

0.0 FTE
5.0 Contract FTE

Special Support Services

0.0 FTE
(contracted service)
Indirect Equivalent to
10.92 FTE

School Resource Officer Program

0.0 FTE
1.0 Contract FTE

Community Storefronts

0.0 FTE
2.0 Contract FTE

Neighborhood Traffic Safety Program

0.0 FTE



Police 2007 Budget

2007 Police Services General Fund Portion as a Share of the General Fund

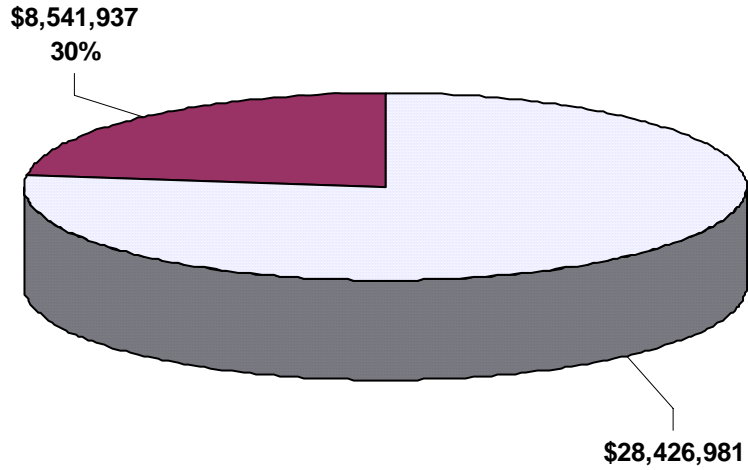

Police Historical Comparison

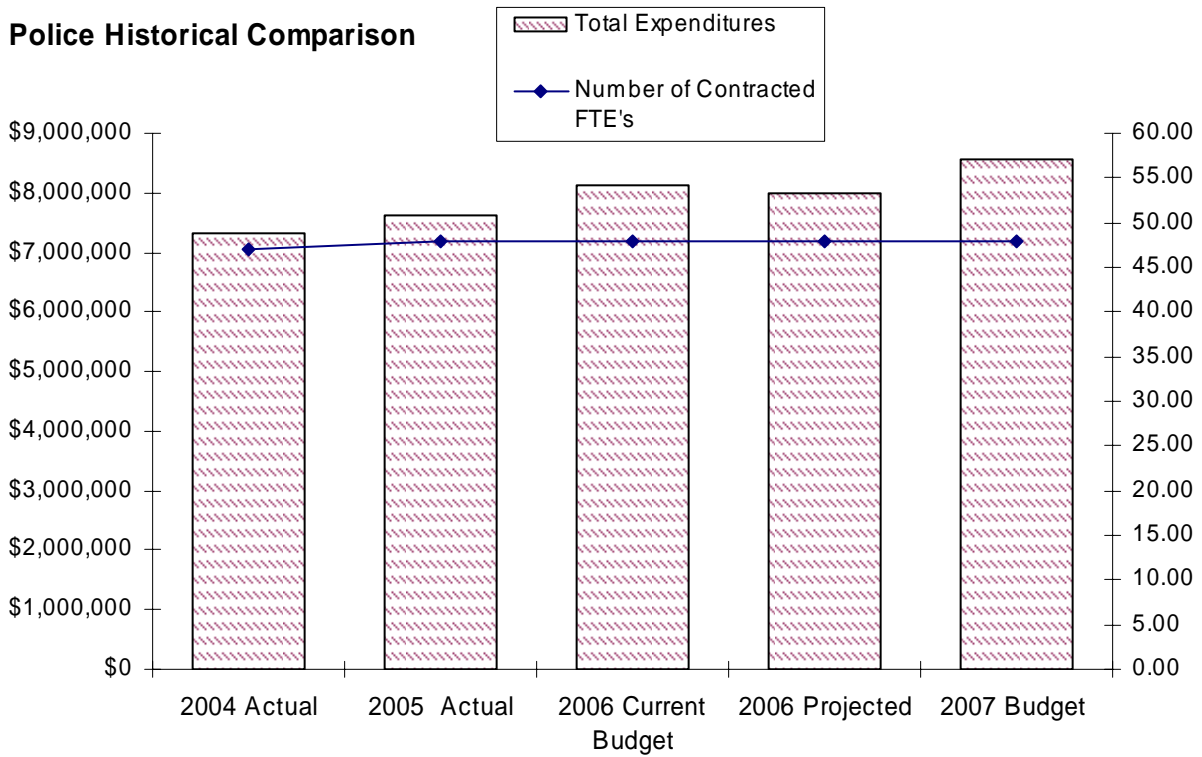



Police 2007 Budget

2006 Key Department Accomplishments in Support of the City's Strategic Objectives:

Safe and Attractive Neighborhoods and Business Districts

- Through the use of centralized crime analysis, identified and responded quickly and efficiently to developing crime trends in order to reduce crime and the fear of crime.
- Developed and enhanced the police responses to emergency management scenarios through drills and preparation of the city's primary (fire station) and secondary (police station) Emergency Operations Centers (EOC's).
- In cooperation with the school district, developed an annual Active Shooter and Patrol (ASAP) training to better prepare for school shooting emergencies, with minimal loss of life.

2007 Key Department Objectives in Support of the City's Strategic Objectives

Safe and Attractive Neighborhoods and Business Districts

- Develop and enhance the police response in the city emergency operations plan through drills to a staged terrorist event. This event would be coordinated through utilization of both the Police and Fire Emergency Operations Centers, following NIMS/ICS training mandates.
- Implement auto theft action plan.
- Implement traffic enforcement enhancement plan.
- Strengthen the Civil Abatement Program in coordination with Code Enforcement program.
- Increase active block watch programs.
- Continue to develop the motel/hotel trespass program through partnerships with our property owners to include on-going education and training.
- In cooperation with Public Works, identify high traffic accident areas and work to reduce the number of traffic collisions.
- Establish a safety committee to enhance neighborhood/student safety and awareness through cooperation with Shoreline Fire, the Shoreline School District and city staff.



Police 2007 Budget

Police 2004 - 2007 Budget Comparison By Program							
Program Budget	2004 Actual	2005 Actual	2006 Current Budget	2006 Projected	2007 Budget	2006 Current Budget versus 2007 Budget	Percent Change
Administration	\$614,769	\$757,268	\$768,850	\$769,678	\$853,917	\$85,067	11.06%
Police Community Storefronts	\$237,243	\$247,361	\$261,079	\$260,927	\$277,216	\$16,137	6.18%
Police Investigations Crime Analysis	\$484,681	\$495,410	\$516,421	\$515,183	\$543,009	\$26,588	5.15%
Street Crime Investigations	\$380,821	\$389,251	\$405,760	\$404,786	\$426,650	\$20,890	5.15%
Police Patrol	\$3,486,440	\$3,519,339	\$3,719,244	\$3,628,486	\$3,887,465	\$168,221	4.52%
School Resource Officer Program	\$163,821	\$169,993	\$183,328	\$181,074	\$134,896	-\$48,432	-26.42%
Police Support Services	\$1,249,055	\$1,284,079	\$1,482,405	\$1,479,706	\$1,631,435	\$149,030	10.05%
Police Traffic Enforcement	\$487,796	\$518,773	\$672,264	\$666,714	\$700,404	\$28,140	4.19%
Teen Recreation*	\$41,994	\$32,384	\$37,076	\$37,317	\$36,945	-\$131	-0.35%
Neighborhood Traffic Safety Program**	\$52,773	\$43,647	\$50,000	\$50,297	\$50,000	\$0	0.00%
Emergency Management Planning ¹	\$110,079	\$162,413	\$0	\$0	\$0	\$0	0.00%
Asset Seizure	\$653	\$9,387	\$23,000	\$6,694	\$23,500	\$500	2.17%
Total Program Budget	\$7,310,125	\$7,629,305	\$8,119,427	\$8,000,862	\$8,565,437	\$446,011	5.49%
Program Revenue							
Administration	\$24,409	\$17,027	\$0	\$1,290	\$1,290	\$1,290	0.00%
Police Community Storefronts	\$0	\$0	\$0	\$0	\$0	\$0	0.00%
Police Investigations Crime Analysis	\$0	\$0	\$0	\$0	\$0	\$0	0.00%
Street Crime Investigations	\$0	\$0	\$0	\$0	\$0	\$0	0.00%
Public Safety Patrol	\$1,109,567	\$1,137,085	\$1,198,757	\$1,177,058	\$1,320,718	\$121,961	10.17%
School Resource Officer Program	\$97,197	\$136,422	\$91,010	\$110,015	\$32,000	-\$59,010	-64.84%
Police Support Services	\$2,182	\$24,574	\$0	\$15,105	\$0	\$0	0.00%
Police Traffic Enforcement	\$138,352	\$73,065	\$31,660	\$17,768	\$31,660	\$0	0.00%
Teen Recreation*	\$9,926	\$3,055	\$10,238	\$1,878	\$10,439	\$201	1.96%
Neighborhood Traffic Safety Program**	\$0	\$0	\$0	\$0	\$0	\$0	0.00%
Emergency Management Planning	\$76,044	\$83,239	\$0	\$0	\$0	\$0	0.00%
Asset Seizure	\$3,831	\$10,774	\$23,500	\$18,803	\$23,500	\$0	0.00%
Total Program Revenue	\$1,461,508	\$1,485,241	\$1,355,165	\$1,341,917	\$1,419,607	\$64,442	4.76%
General Fund Subsidy	\$5,848,617	\$6,144,064	\$6,764,262	\$6,658,945	\$7,145,830	\$381,568	5.64%
Total Resources	\$7,310,125	\$7,629,305	\$8,119,427	\$8,000,862	\$8,565,437	\$446,011	5.49%



Police 2007 Budget

2007 Police Programs

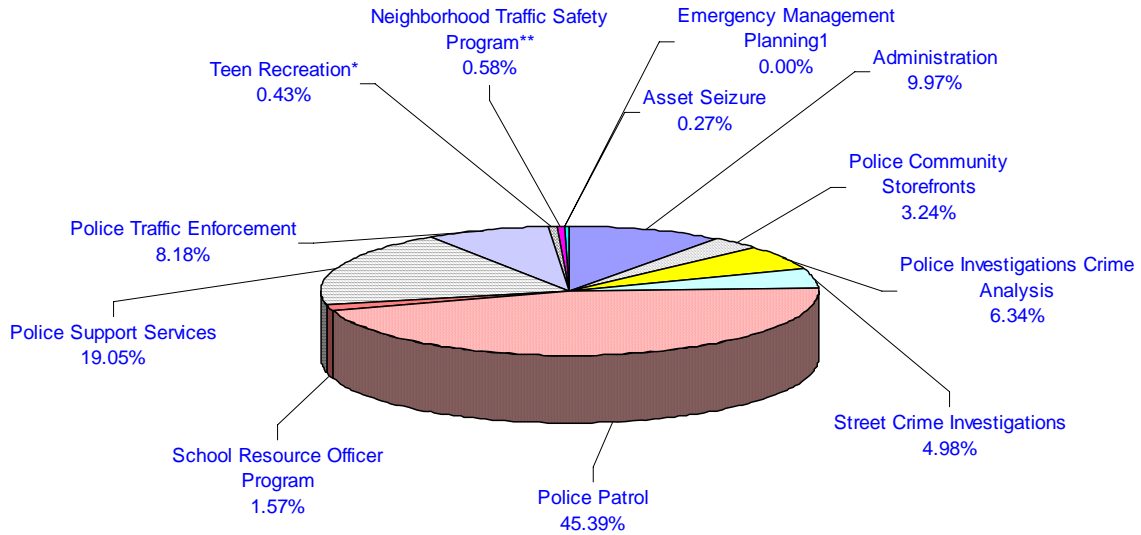

* The Total cost of the Teen Recreation program is \$418,219 for 2007. The remaining \$381,274 can be found in Parks, Recreation and Cultural Services. This is for Police Overtime to participate in the evening recreational programs.

** Traffic Services/Neighborhood Traffic Safety Program is also budgeted in Public Works (\$408,714).

¹ Emergency Management Planning moved to the City Manager's Office in 2006



Police 2007 Budget

Police 2004 - 2007 Operating Budget Comparison By Object							
Object Category	2004 Actual	2005 Actual	2006 Current Budget	2006 Projected	2007 Budget	2006 Current Budget versus 2007 Budget	Percentage Change
Salary	\$72,836	\$99,639	\$46,011	\$46,011	\$47,738	\$1,727	3.8%
Benefits	\$21,867	\$29,351	\$14,383	\$14,383	\$17,316	\$2,933	20.39%
Supplies	\$37,761	\$112,437	\$60,300	\$40,678	\$62,090	\$1,790	2.97%
Services	\$53,991	\$87,973	\$55,559	\$45,810	\$66,347	\$10,788	19.42%
Intergovernmental Services	\$7,099,696	\$7,276,094	\$7,933,620	\$7,840,426	\$8,361,554	\$427,934	5.4%
Capital	\$14,249	\$16,758	\$0	\$4,000	\$0	\$0	0.00%
Interfund Payments for Service	\$9,725	\$7,053	\$9,554	\$9,554	\$10,392	\$838	8.8%
Total Expenditures	\$7,310,125	\$7,629,305	\$8,119,427	\$8,000,862	\$8,565,437	\$446,010	5.5%
Revenue Source							
Taxes	\$1,035,325	\$1,111,985	\$1,100,687	\$1,150,687	\$1,224,500	\$123,813	0.0%
Intergovernmental Revenues	\$294,197	\$312,914	\$220,978	\$157,949	\$160,317	-\$60,661	(27.5%)
Charges for Goods and Services	\$0	\$0	\$0	\$287	\$0	\$0	
Fines and Forfeits	\$126,748	\$46,538	\$10,000	\$12,901	\$10,000	\$0	0.0%
Miscellaneous Revenues	\$5,238	\$13,804	\$24,790	\$20,093	\$24,790	\$0	0.0%
Total Revenue	\$1,461,508	\$1,485,241	\$1,356,455	\$1,341,917	\$1,419,607	\$63,152	4.7%
General Fund Subsidy	\$5,848,617	\$6,144,064	\$6,762,972	\$6,658,945	\$7,145,830	\$382,858	5.7%
Total Resources	\$7,310,125	\$7,629,305	\$8,119,427	\$8,000,862	\$8,565,437	\$446,010	5.5%
Department Statistics							
General Fund Portion of Police as a % of Total General Fund	30.30%	25.86%	27.54%	27.27%	30.05%	2.51%	9.1%
Number of FTE's	1.00	2.00	1.00	1.00	1.00	0.00	0.0%
Number of Contracted FTE's	47.00	48.00	48.00	48.00	48.00	0.00	0.00%

The Police Department budget includes two City funds, the General Fund and the Asset Seizure Fund. The fund breakdown is displayed below.

Budget by Fund	2004 Actual	2005 Actual	2006 Current Budget	2006 Projected	2007 Budget	2006 Current Budget versus 2007 Budget	Percentage Change
General Fund Expenditures	\$7,309,472	\$7,619,918	\$8,096,427	\$7,994,168	\$8,541,937	\$445,510	5.5%
Asset Seizure Fund Expenditures	\$653	\$9,387	\$23,000	\$6,694	\$23,500	\$500	2.2%
Total Expenditures	\$7,310,125	\$7,629,305	\$8,119,427	\$8,000,862	\$8,565,437	\$446,010	5.49%



Police 2007 Budget

2007 Budget Highlights

- Emergency Management Planning was moved to the City Manager's Office in 2006 and the corresponding budget comparison has been moved from Police to the City Manager's Office.
- The King County contract for police services is projected to increase by 5.5% from 2006 to 2007. This increase is \$427,934. Increases are primarily a result of the following three factors:
 - Increases in personnel salaries and benefits
 - Assumption of the wireless system costs for the police laptop computer program. In 2006 these costs were paid for by a grant received by King County. The grant covered the first year of operational costs.
 - The final year of the COPS universal grant was 2006. This grant was awarded to pay \$25,000 a year towards the Administrative Sergeant position that was added in 2004. This was a three year grant.
- Utility costs for the Storefronts and Police station are increasing by \$9,868 from 2006 to 2007.

POLICE ADMINISTRATION

PROGRAM PURPOSE:

Administration establishes policy and priorities in order to deliver police services in Shoreline based upon Council direction and community input

STRATEGIC OBJECTIVES:

Safe and Attractive Neighborhoods and Business Districts

Measurement: EFFECTIVENESS	2004	2005	2006	2007/Target
Complaints by citizens against Shoreline Police Officers	1	2		
Part I Crime Rates Per 1,000 Residents	46.0	47.8		
Percentage of surveyed citizens who indicated that Police were customer service oriented	61%	N/A		

Measurement: EFFICIENCY	2004	2005	2006	2007/Target
Police Costs Per Capita	132.8	136.9		

Measurement: WORKLOAD	2004	2005	2006	2007/Target
Number of Police Contacts	26,879	28,213		

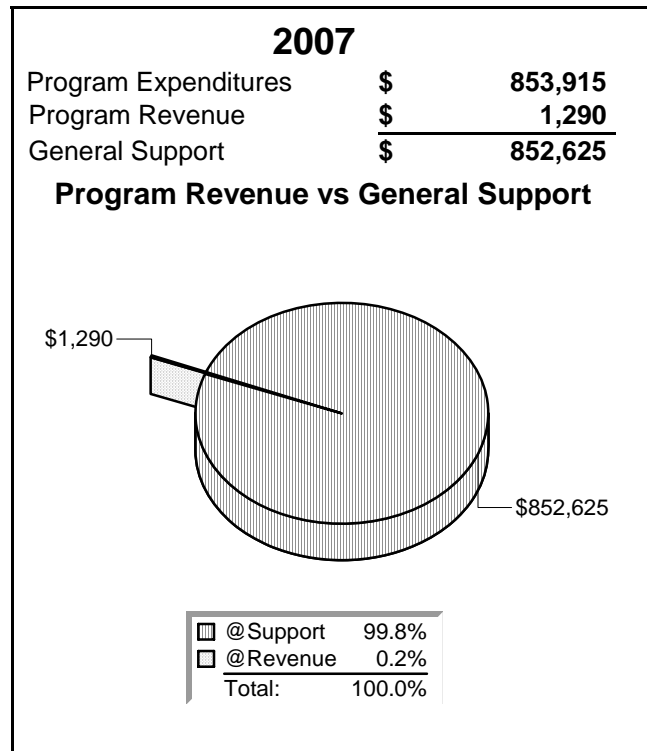
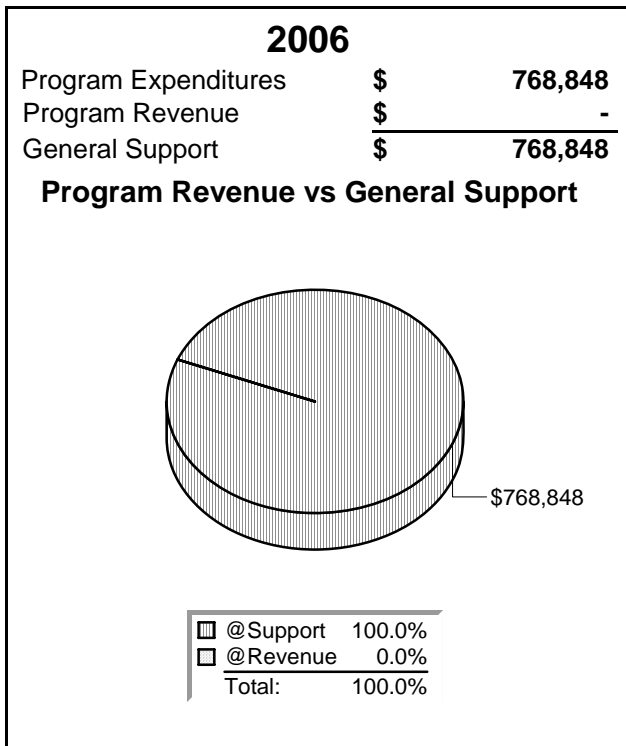

POLICE COMMUNITY STOREFRONTS

PROGRAM PURPOSE:

Community Storefronts work collaboratively with local residents, businesses, and schools in order to address issues that affect the community.

STRATEGIC OBJECTIVES:

Safe and Attractive Neighborhoods and Business Districts

Measurement: EFFECTIVENESS	2004	2005	2006	2007/Target
Number of active block watch groups	125	125	125	

Measurement: WORKLOAD	2004	2005	2006	2007/Target
Court reminder program contacts	2,631	3,338		
Number of Citizen Contacts	3,572	2,195		
Number of crime prevention vacation house checks performed	335	215	240	
Storefront Volunteer Hours		4,734	5,000	
Victim Call Back Calls made.	180	670		

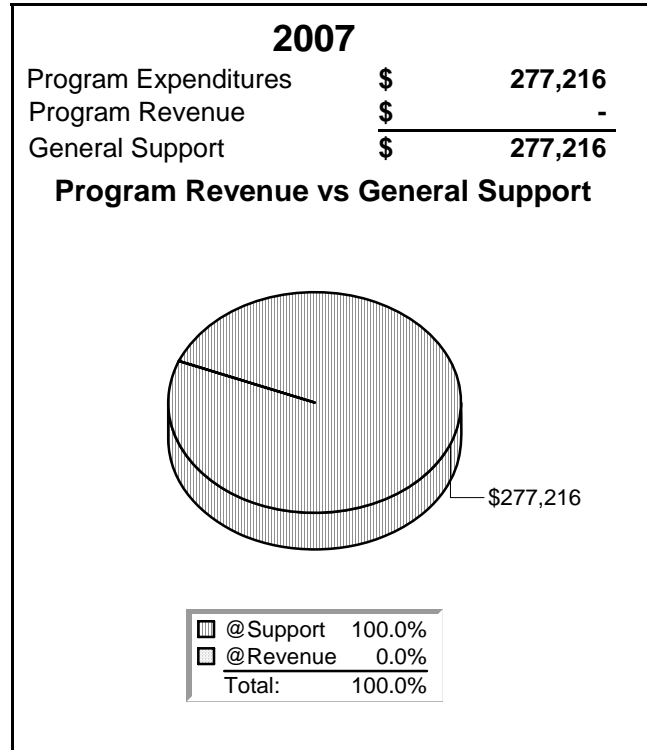
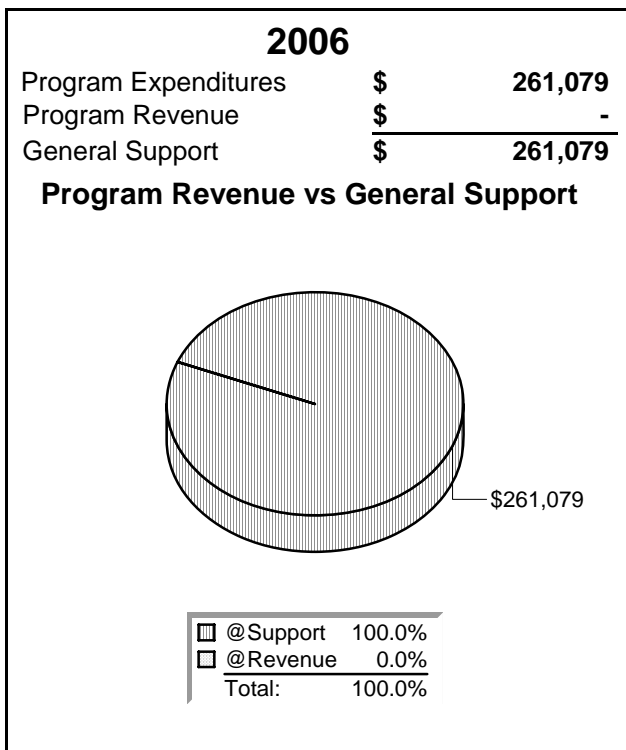

POLICE INVESTIGATIONS CRIME ANALYSIS

PROGRAM PURPOSE:

To investigate crime and solve cases in order to keep the community safe.

STRATEGIC OBJECTIVES:

Safe and Attractive Neighborhoods and Business Districts

Measurement: EFFECTIVENESS	2004	2005	2006	2007/Target
Number of cases closed and cleared by arrest (Part I and Part II Crimes)	1,150	1,377		

Measurement: WORKLOAD	2004	2005	2006	2007/Target
Number of Adult Charges & Arrest	1,266	1,357		
Number of Juvenile Charges & Arrest	191	214		
Part I crime	2424	2507		

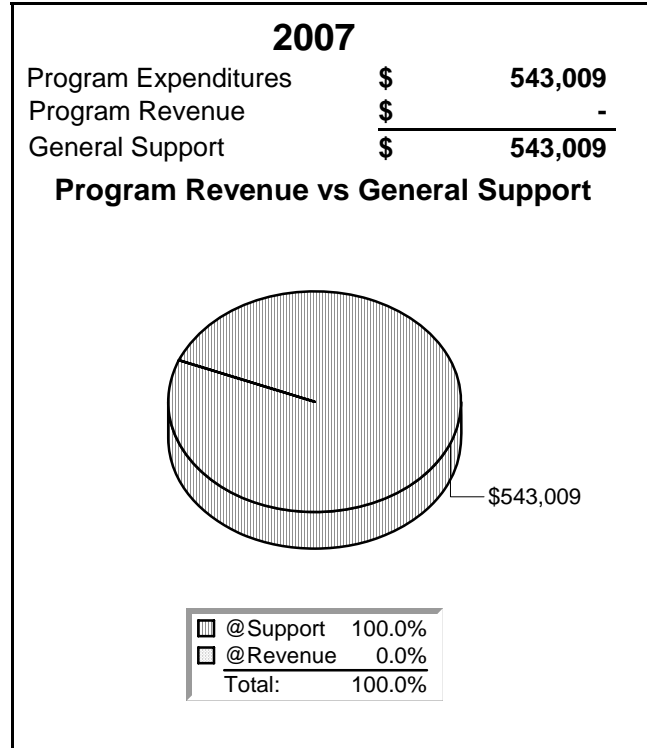
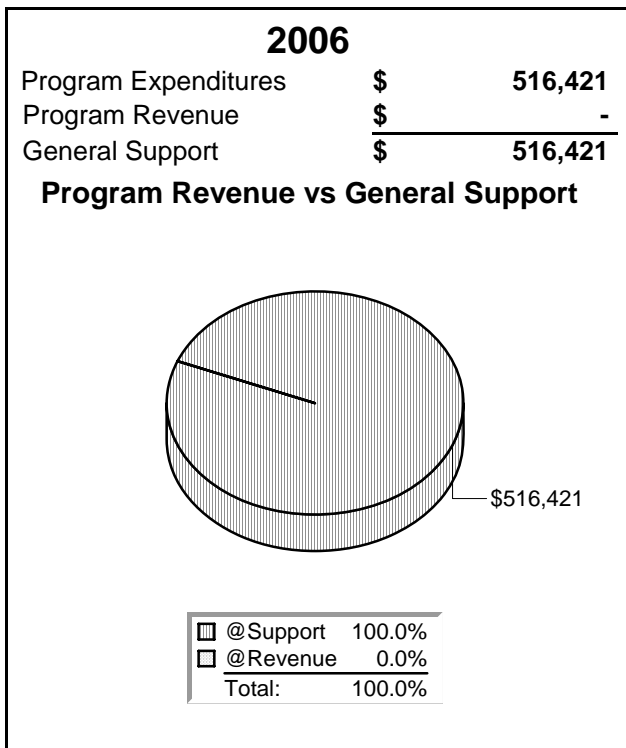

STREET CRIME INVESTIGATIONS

PROGRAM PURPOSE:

The Street Crimes Unit proactively responds to crimes such as narcotics activities, code violations in the adult entertainment industry and vice activities in the City; to investigate these crimes and solve cases in order to keep the community safe and improve the quality of life for residents.

STRATEGIC OBJECTIVES:

Safe and Attractive Neighborhoods and Business Districts

Measurement: WORKLOAD	2004	2005	2006	2007/Target
Felony Charges Filed	78	155		
Misdemeanor cases closed "Cleared by Arrest"	89	111		
Number of Assigned Narcotic Activity Reports (neighborhood drug complaints)	26	15		
Number of Narcotics Investigations	67	85		
Number of Vice Arrests	54	59		

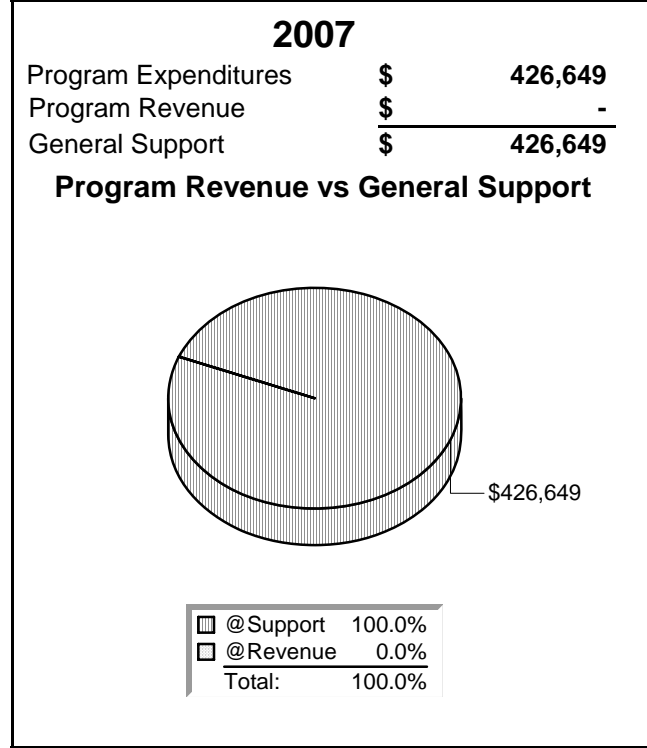
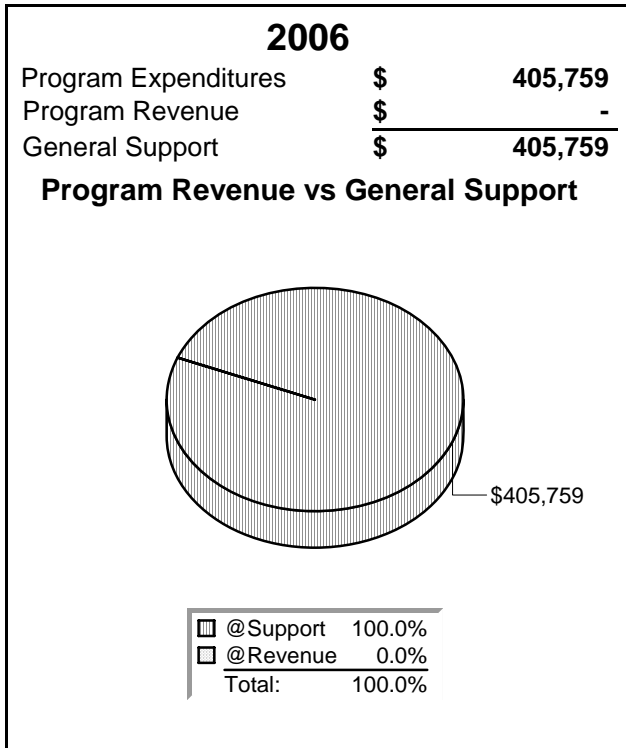

POLICE PATROL

PROGRAM PURPOSE:

Patrol responds to calls for service, enforces criminal laws and performs self-initiating activity to keep citizens safe.

STRATEGIC OBJECTIVES:

Safe and Attractive Neighborhoods and Business Districts

Measurement: EFFECTIVENESS	2004	2005	2006	2007/Target
Percentage of citizens feeling safe in their neighborhood at night	73.0%		N/A	
Percentage of citizens feeling safe in their neighborhood during the day	95%			
Response Time to Priority 1 Calls	6.81	6.71		
Response Time to Priority 2 Calls	11.37	11.59		
Response time to Priority X Calls	3.62	3.98		

Measurement: WORKLOAD	2004	2005	2006	2007/Target
Number of Alternative Calls Handled	1,051	963		
Number of dispatched calls for service.	13,842	14,115		
Number of Self-initiated Police Activities	13,037	14,615		

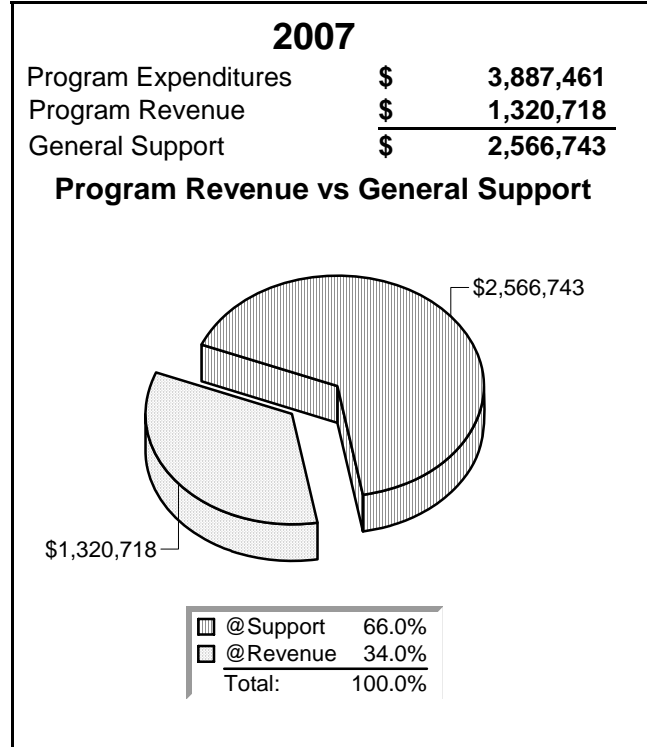
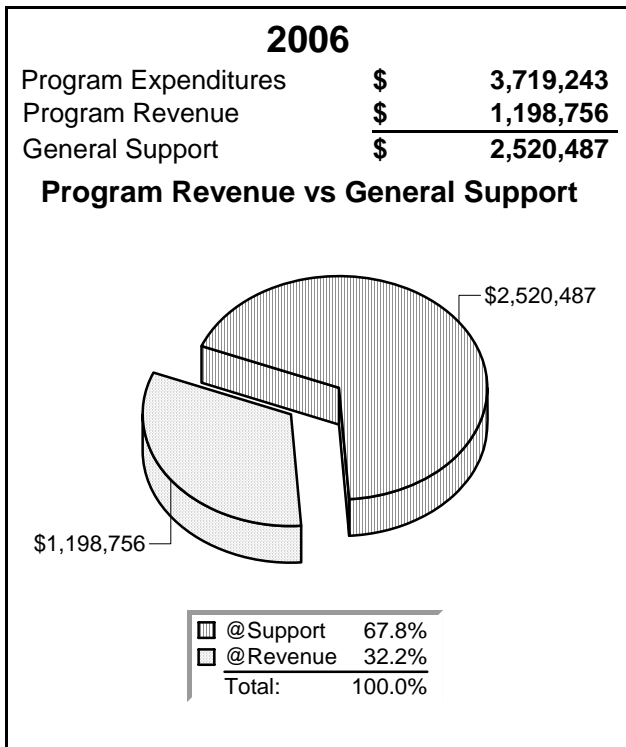

SCHOOL RESOURCE OFFICER PROGRAM

PROGRAM PURPOSE:

The School Resource Officer (SRO) program facilitates a safe learning environment for students and staff; SRO's provide security, mentoring, and teach a variety of classes to students and staff in the Shoreline School District and some private schools in Shoreline.

STRATEGIC OBJECTIVES:

Safe and Attractive Neighborhoods and Business Districts

Measurement: WORKLOAD	2004	2005	2006	2007/Target
Number of Classes Taught through the SRO program	43	162		
Number of School Resource Officer Hours	1,052	3,192		
Number of students taught	1,583	3341		

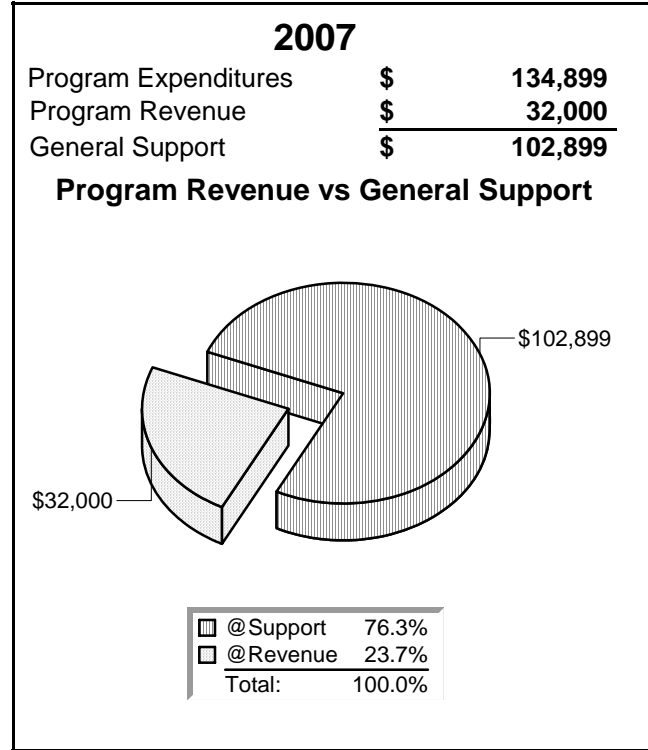
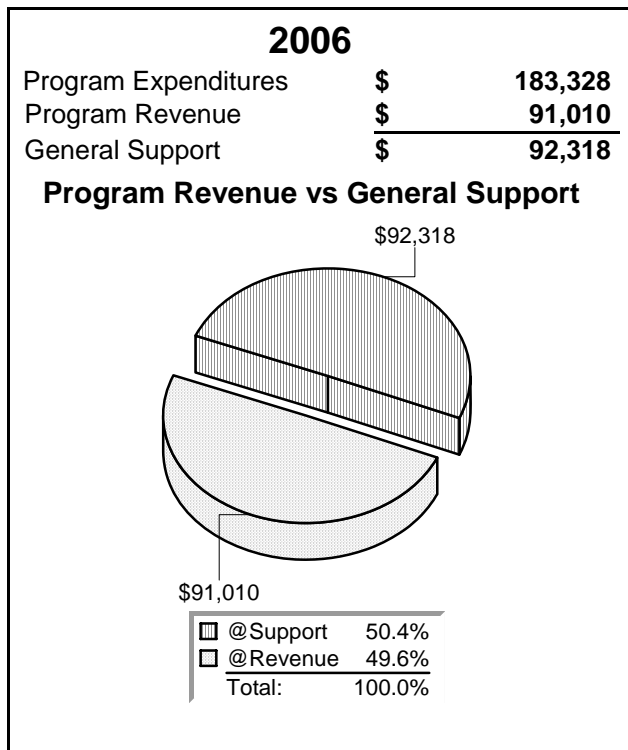

POLICE SUPPORT SERVICES (911 CENTER, MAJOR CRIME INVESTIGATION, CANINE SERVICES, ETC.)

PROGRAM PURPOSE:

Support Services provides emergency communications and special investigation on major crimes in order to solve cases committed in Shoreline and apprehend offenders.

STRATEGIC OBJECTIVES:

Safe and Attractive Neighborhoods and Business Districts

Measurement: WORKLOAD	2004	2005	2006	2007/Target
Dispatched calls for service	13,842	14,115		
Number of Air Support (Helicopter) Flight Hours	6.15	7		
Number of Bomb Disposal Unit responses	6	5		
Number of canine calls for service	182	63		
Number of Hostage & Barricade Incidents	0	6		
Number of major accidents reconstruction incidents (3 year average)	13	23		
Total number of canine hours of service	257.75	120		

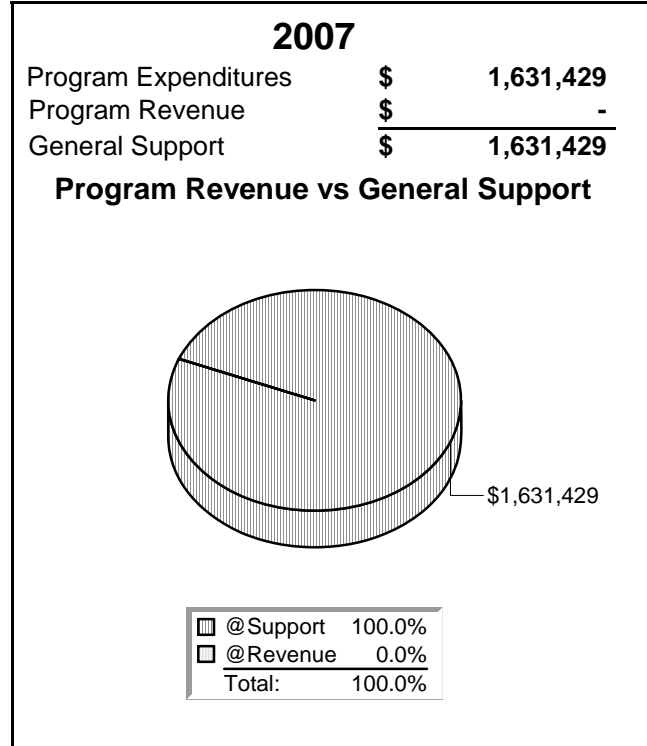
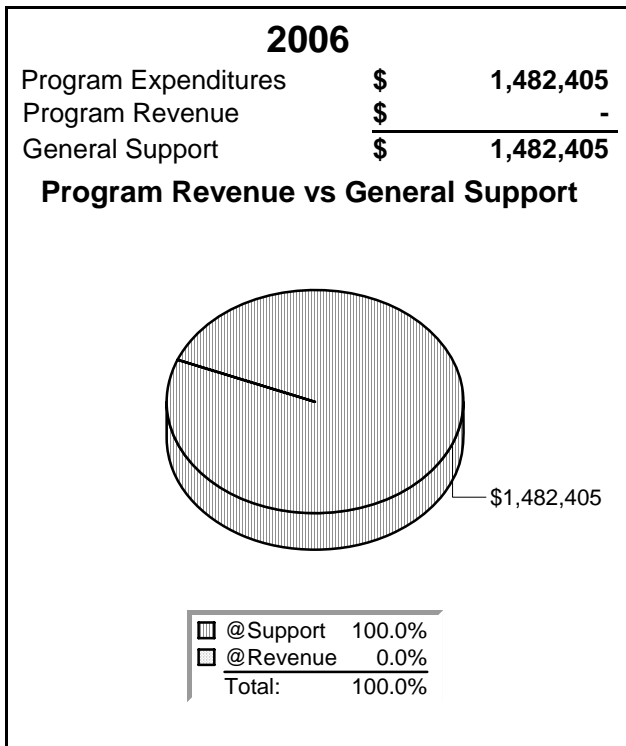

POLICE TRAFFIC ENFORCEMENT

PROGRAM PURPOSE:

The Traffic Unit provides motorist education and enforces traffic laws, with the City of Shoreline in order to keep motorists and citizens safe.

STRATEGIC OBJECTIVES:

Safe and Attractive Neighborhoods and Business Districts

Measurement: EFFECTIVENESS	2004	2005	2006	2007/Target
Percentage of citizens who are satisfied or very satisfied with the enforcement of local traffic laws.	64%		N/A	
Percentage of surveyed citizens who indicated they were concerned or very concerned about speeding traffic	66.0%			

Measurement: WORKLOAD	2004	2005	2006	2007/Target
Number of citizen traffic complaints referred to Police Department	292	188		
Number of collisions	614	555		
Number of Traffic Citations & Notices of Infractions	4,847	5,523		

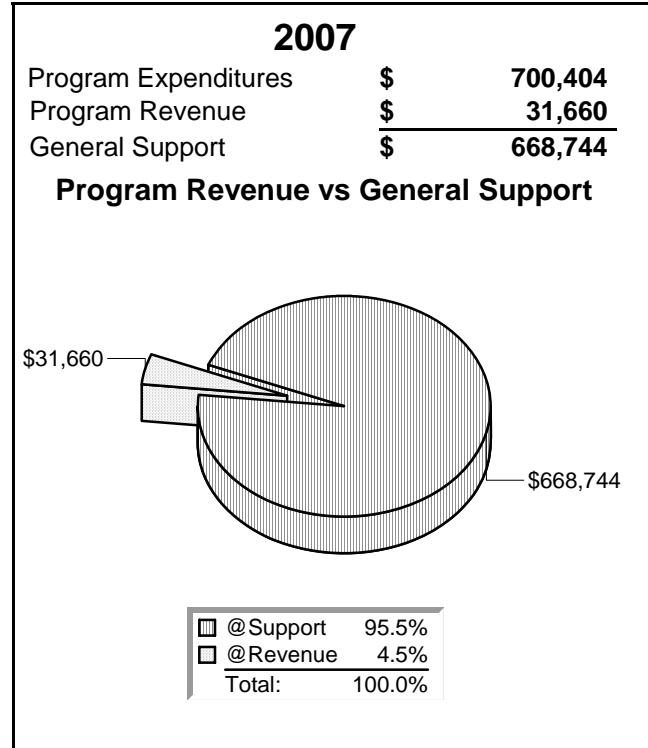
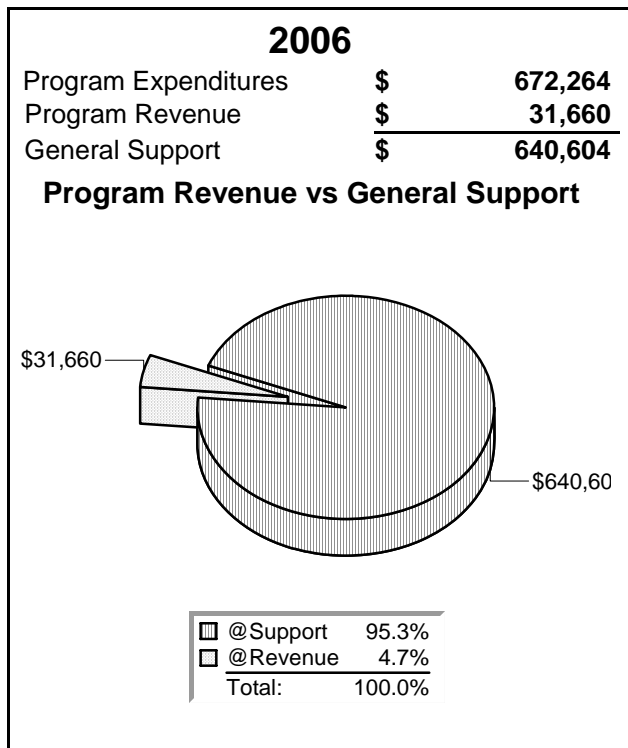

TRAFFIC SERVICES & NEIGHBORHOOD TRAFFIC SAFETY

PROGRAM PURPOSE:

Responsible for plan review, design and approval of all traffic control devices including streetlights, crosswalks, signals, signs, striping, etc; maintenance of traffic-related records including accident reports and signage/crosswalk inventories; preparation and documentation of city traffic standards; traffic counts and investigations and community education.

Provide traffic counts and investigations, community education, and management of the City's Neighborhood Traffic Safety Program (NTSP). Design traffic calming solutions that enhance the quality of life for Shoreline residents. Provide funding for special emphasis police traffic enforcement.

STRATEGIC OBJECTIVES:

Quality Services, Facilities and Infrastructure

Measurement: EFFECTIVENESS	2004	2005	2006	2007/Target
Percentage of citizens surveyed who are very satisfied or somewhat satisfied with the flow of traffic and congestion.	41%	41%	N/A	N/A
Percentage of services requests completed on time.	90%	95%	95%	100%

Measurement: WORKLOAD	2004	2005	2006	2007/Target
Number of active residential areas involved in the NTSP Program	45	38	42	42
Number of residential area traffic projects completed per year	7	25	50	25
Number of service requests received	104	132	221	150
Number of targeted law enforcement hours in a NTSP residential area.	946	954	950	950
Number of traffic counts completed each year	382	308	350	350
Number of work orders issued	350	329	350	350

TRAFFIC SERVICES & NEIGHBORHOOD TRAFFIC SAFETY

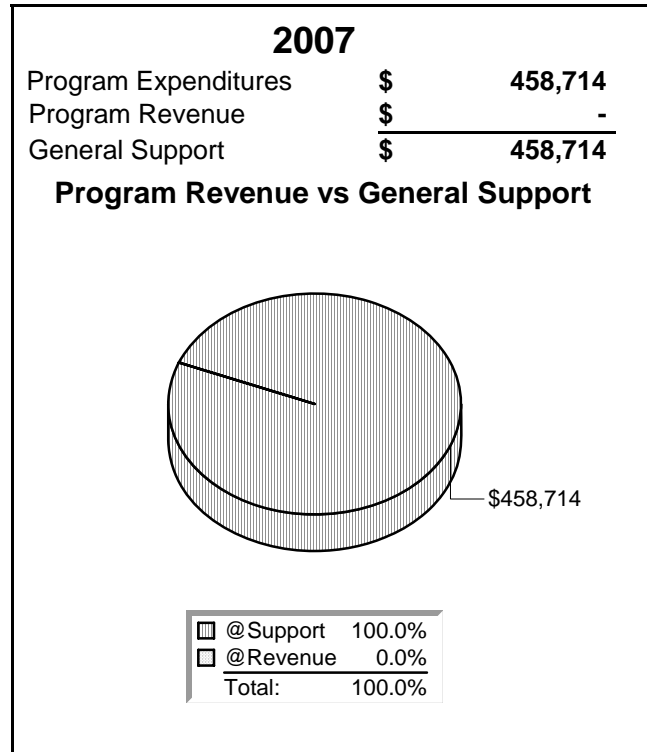
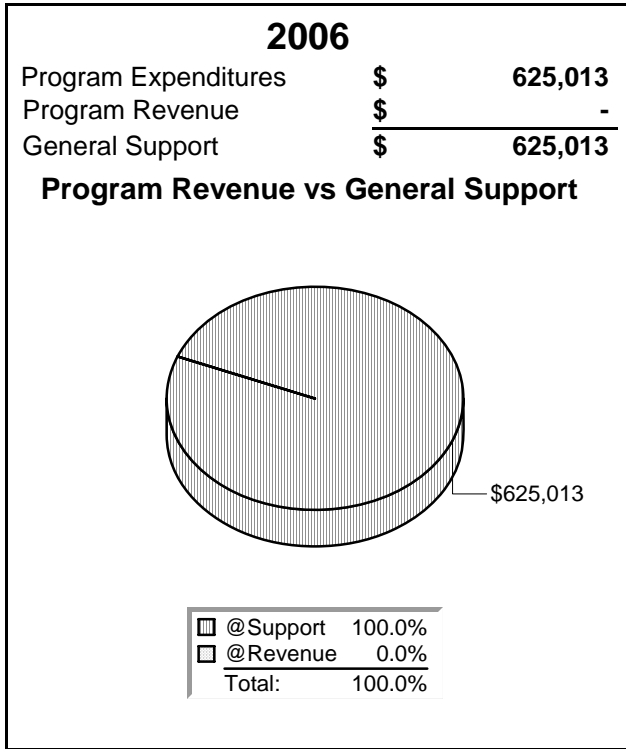

TEEN RECREATION PROGRAMS

PROGRAM PURPOSE:

The Teen Recreation program help youth in the community, ages 12-19 years old, make successful life choices by being positive role models and offering diverse, challenging, safe and innovative programs. As a means of gauging progress toward this goal, the program uses 9 of the 40 Search Institute's Development Assets for success as guiding factors. The assets chosen focus on the following: giving teens useful roles, valuing their opinions, giving clear expectations, doing their homework, volunteerism, increasing their sense of personal responsibility, non-violent conflict resolution, adding more caring adults in their lives and helping them feel more in control over their life.

STRATEGIC OBJECTIVES:

Quality Services, Facilities and Infrastructure

Measurement: EFFECTIVENESS	2004	2005	2006	2007/Target
Percentage of surveyed participants that always or sometimes feel that the Teen Program provides all 9 of the development assets	82%	82%	83%	84%

Measurement: EFFICIENCY	2004	2005	2006	2007/Target
Net cost per hour of teen recreation programs (net of revenue)	\$99.56	\$130.09	\$125.62	
Net Cost per Visit (net of revenues)	\$8.51	\$11.76	\$11.06	\$11.06

Measurement: WORKLOAD	2004	2005	2006	2007/Target
Number of teen recreation program hours	3,197	2,719	2,847	2,800
Number of visits in the Teen Late Night Programs	11,507	8,977	9,250	9,200
Number of visits to all Teen Programs excluding Late Night	22,213	22,561	22,818	23,000
Total number of all visits.	33,720	31,538	32,068	32,200

TEEN RECREATION PROGRAMS

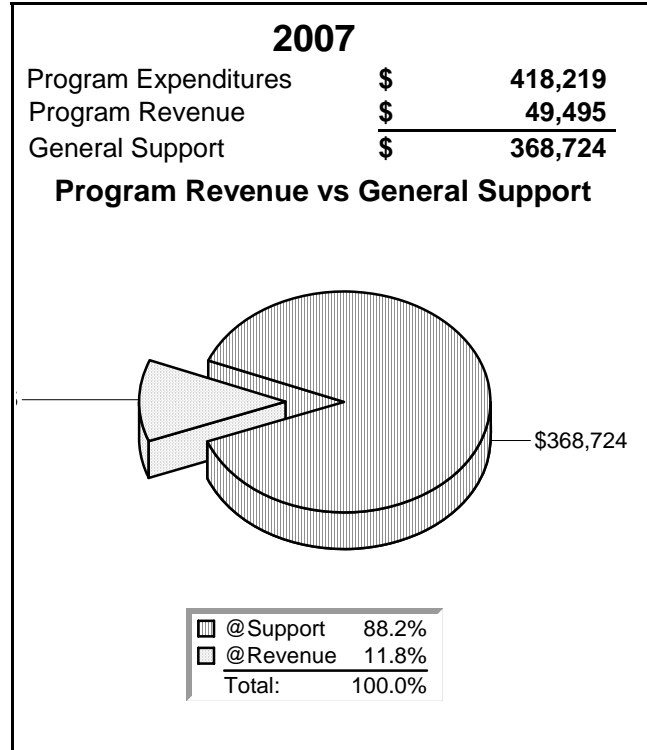
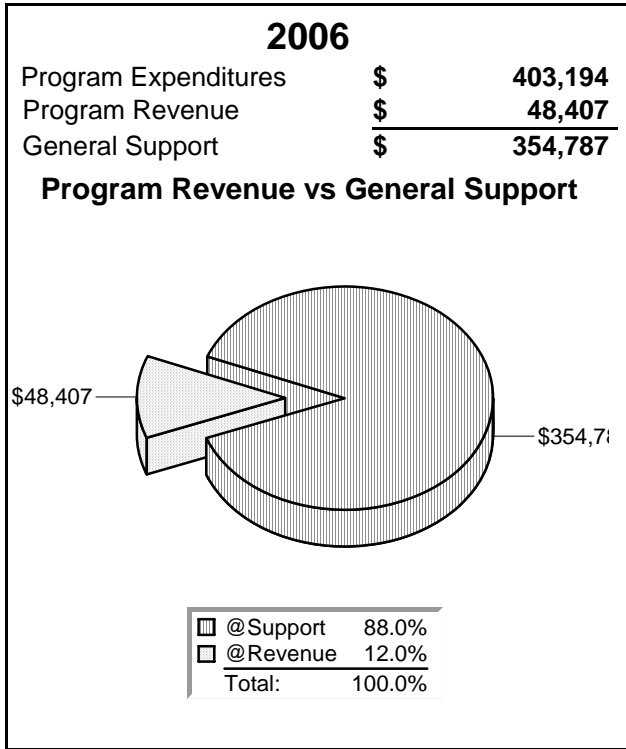



This Page Has Been Intentionally Left Blank



Criminal Justice



Criminal Justice 2007 Budget

Mission Statement

“The mission of the Criminal Justice program is to provide for the fair and timely adjudication of misdemeanor cases and develop cost effective alternatives to effect the resulting judicial decisions and sentencing requirements.”

Department Programs

Jail Contract

0.0 FTE
(Contract Service)

Public Defender

0.0 FTE
(Contract Service)

Municipal Court

0.0 FTE
(Contract Service)

2007 Criminal Justice as a Share of the General Fund

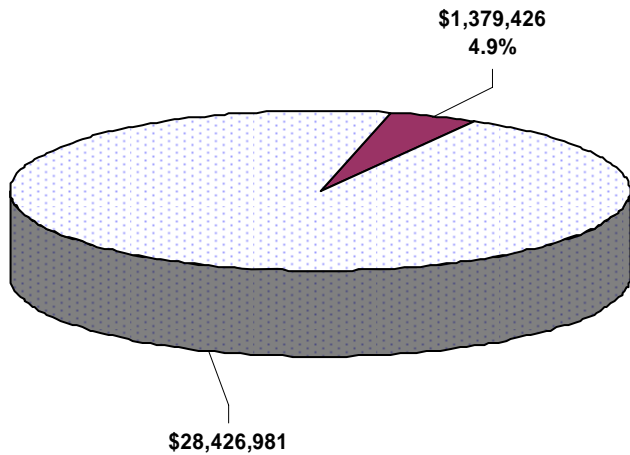

Criminal Justice Historical Comparison

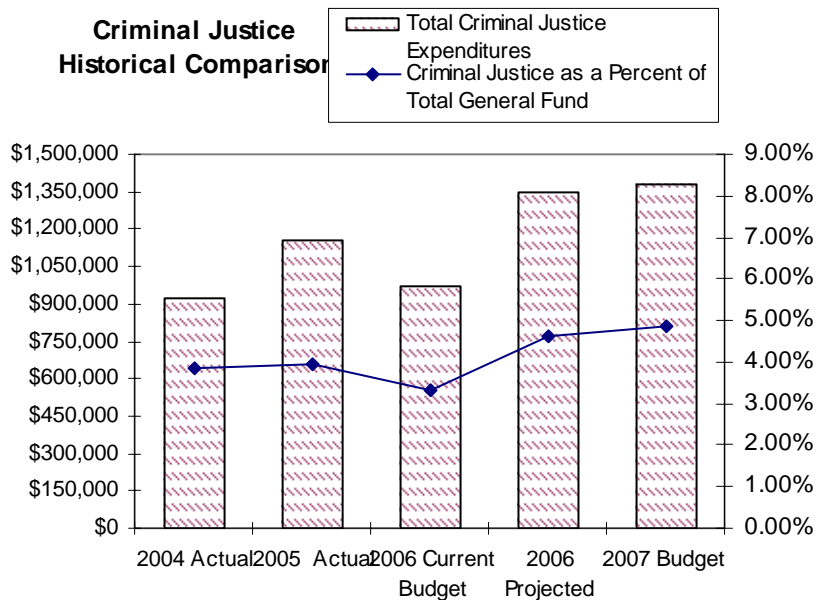



Criminal Justice 2007 Budget

2006 Key Department Accomplishments in Support of the City's Strategic Objectives:

Quality Services, Facilities and Infrastructure

- Completed the work of assessing the City's future municipal court options.

Economic Vitality and Financial Stability

- Continued to work to assure the City's jail population was housed in the most cost effective way possible.

2007 Key Department Objectives in Support of the City's Strategic Objectives

Economic Vitality and Financial Stability

- Continue to work to decrease Jail costs by increasing use of alternative sentencing methods and increase the City's use of Yakima County jail.



Criminal Justice 2007 Budget

Criminal Justice 2004 - 2007 Budget Comparison By Program							
Expenditures by Program	2004 Actual	2005 Actual	2006	2006	2007 Budget	2006 Current	Percentage
			Current Budget	Projected		Budget versus 2007 Budget	
Jail	\$791,845	\$1,020,449	\$839,000	\$1,200,300	\$1,225,217	\$386,217	46.03%
Public Defender	\$132,336	\$136,461	\$134,104	\$148,100	\$154,209	\$20,105	14.99%
Municipal Court (Contracted Service)	\$0	\$0	\$0	\$0	\$0	\$0	0.00%
Total Program Expenditures	\$924,181	\$1,156,910	\$973,104	\$1,348,400	\$1,379,426	\$406,322	41.76%
Revenue By Program							
Jail	\$0	\$0	\$0	\$0	\$0	\$0	0.0%
Public Defender	\$914	\$327	\$1,000	\$0	\$0	-\$1,000	0.0%
Municipal Court (Contracted Service)	\$0	\$0	\$0	\$0	\$0	\$0	0.0%
Total Revenue	\$914	\$327	\$1,000	\$0	\$0	-\$1,000	0.0%
General Fund Subsidy	\$923,267	\$1,156,583	\$972,104	\$1,348,400	\$1,379,426	\$407,322	41.90%
Total Criminal Justice Resources	\$924,181	\$1,156,910	\$973,104	\$1,348,400	\$1,379,426	\$406,322	41.76%
Department Statistics							
Contracted Service no FTEs	NA	NA	NA	NA	NA	NA	NA

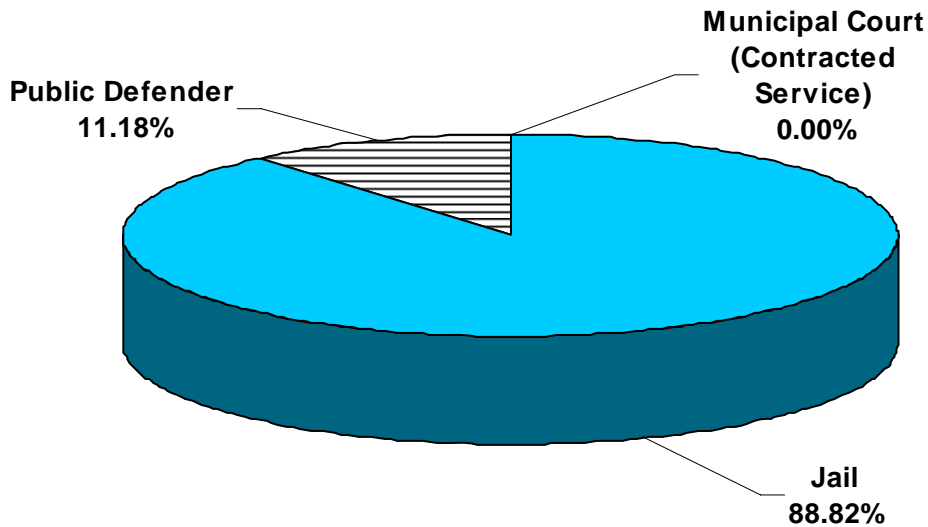



Criminal Justice 2007 Budget

Criminal Justice 2004- 2007 Budget Comparison By Object								
Object Category Name	2004 Actual	2005 Actual	2006 Current Budget	2006 Projected	2007 Budget	2006 Current Budget versus 2007 Budget	Percentage Change	
Salary	\$0	\$0	\$0	\$0	\$0	\$0	0.0%	
Benefits	\$0	\$0	\$0	\$0	\$0	\$0	0.0%	
Supplies	\$0	\$0	\$0	\$0	\$0	\$0	0.0%	
Services	\$132,132	\$134,285	\$134,104	\$145,300	\$150,709	\$16,605	12.4%	
Intergovernmental Services	\$792,049	\$1,022,625	\$839,000	\$1,203,100	\$1,228,717	\$389,717	46.45%	
Capital	\$0	\$0	\$0	\$0	\$0	\$0	0.0%	
Interfund Payments for Service	\$0	\$0	\$0	\$0	\$0	\$0	0.0%	
Total Criminal Justice Expenditures	\$924,181	\$1,156,910	\$973,104	\$1,348,400	\$1,379,426	\$406,322	41.76%	
Revenue Source								
Licenses and Permits	\$0	\$0	\$0	\$0	\$0	\$0	0.0%	
Intergovernmental Revenues	\$0	\$0	\$0	\$0	\$0	\$0	0.0%	
Fines	\$914	\$327	\$1,000	\$0	\$0	-\$1,000	0.0%	
Miscellaneous Revenues	\$0	\$0	\$0	\$0	\$0	\$0	\$0	
Total Revenue	\$914	\$327	\$1,000	\$0	\$0	-\$1,000	(100.0%)	
General Fund Subsidy	\$923,267	\$1,156,583	\$972,104	\$1,348,400	\$1,379,426	\$407,322	41.90%	
Total Criminal Justice Resources	\$924,181	\$1,156,910	\$973,104	\$1,348,400	\$1,379,426	\$406,322	41.76%	
Department Statistics								
Criminal Justice as a Percent of Total General Fund	3.83%	3.93%	3.31%	4.60%	4.85%	1.54%	46.6%	
Contracted Service no FTE's	NA	NA	NA	NA	NA	NA	NA	

2007 Budget Highlights

- At this time there is no budget for District Court costs, as it is anticipated that the revenue received by the King County District court for Shoreline related infractions will offset the cost of the services provided by the court. If this is not the case the City may have to pay the difference between revenue received and costs incurred on Shoreline's behalf.
- The contract for public defense contains an annual escalator equal to the City's annual market rate adjustment. The 2007 market rate adjustment is 3.78%. This increase results in a \$5,500 increase in the contract.
- The 2007 budget for prosecuting services includes a \$10,795 budget for conflict resolution services.
- In 2006 the City started paying King County for public defense screening. The estimated cost for this service is \$3,500 in 2007 and has been included within the Public Defender program.
- The 2006 projected jail expenditures are \$1,200,000, \$361,000 more than the 2006 budget. Jail usage jumped significantly in August 2005. It is expected that the current jail usage trends will continue into the future and therefore the 2007 jail budget shows a \$386,217 increase when compared to the 2006 budget. The total jail budget for 2007 is \$1,225,217.

JAIL

PROGRAM PURPOSE:

The Jail program accounts for the costs of screening, booking and imprisonment of misdemeanor offenders. This service is provided through interlocal agreements with the King County and Yakima County jails.

STRATEGIC OBJECTIVES:

Safe and Attractive Neighborhoods and Business Districts

Measurement: EFFICIENCY	2004	2005	2006	2007/Target
Average cost per jail day used	\$89.89	\$82.22		
Percentage of days held at Yakima County Jail Facility	47%	60.09%		

Measurement: WORKLOAD	2004	2005	2006	2007/Target
Total Jail Days Used	7,702	12,086	N/A	

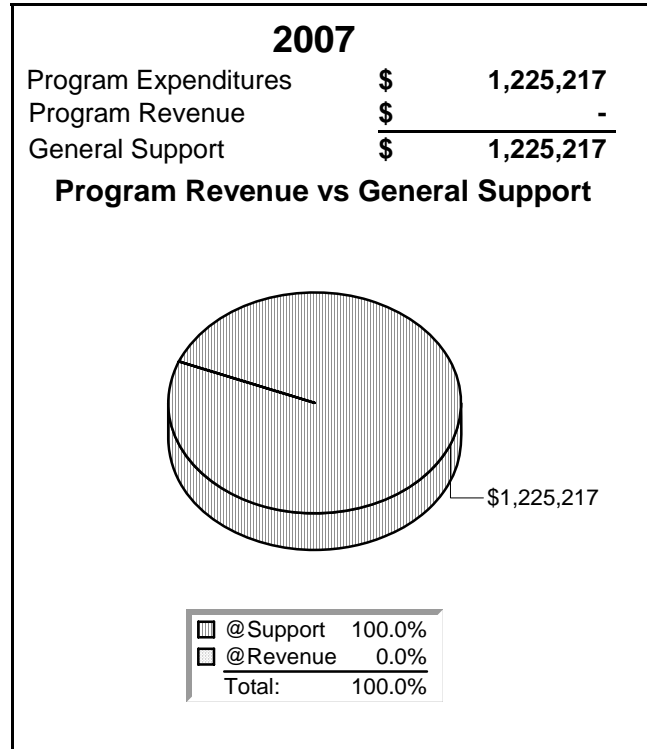
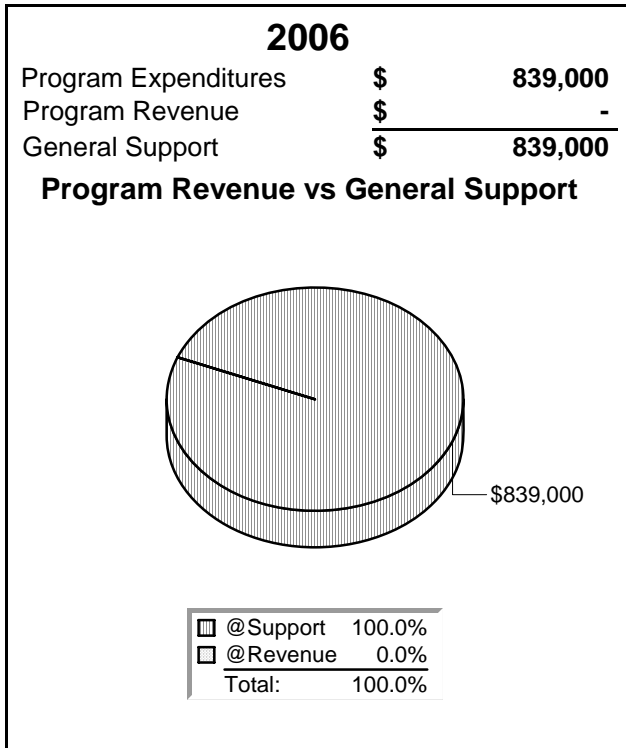

PUBLIC DEFENDER

PROGRAM PURPOSE:

The Public Defender provides legal representation for indigent criminal defendants

STRATEGIC OBJECTIVES:

Governmental Excellence

Measurement: WORKLOAD	2004	2005	2006	2007/Target
Number of cases represented	774	600	650	

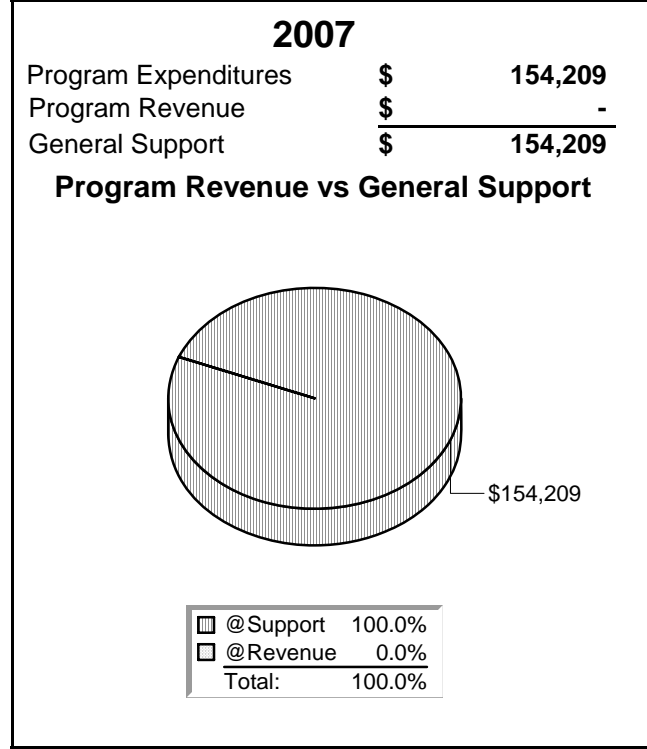
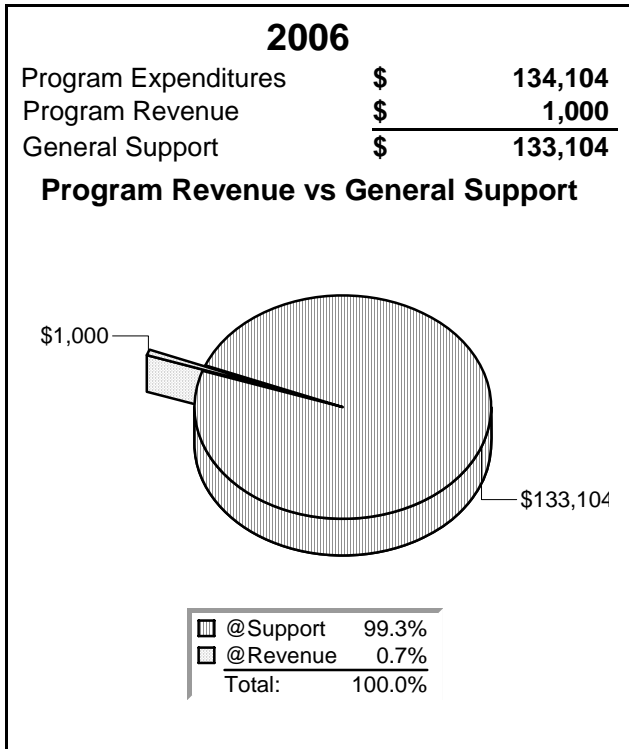



***Parks, Recreation
and Cultural
Services***



Parks, Recreation and Cultural Services (PRCS) 2007 Budget

Mission Statement

“Provide life-enhancing experiences and promote a healthy community, and to bring our culture to life and transfer it to the next generation”

Department Programs

Parks Administration

4.00 FTE

Athletic Field Maintenance & Operations

2.075 FTE

Parks & Open Space Maintenance

5.525 FTE

Aquatics

5.625 FTE

Recreation Facility Rental Program

.37 FTE

General Recreation Programs

3.9 FTE

Teen Recreation Programs

4.05 FTE

Parks Cultural Services Programs

.75 FTE

*An Additional Parks & Recreation .5 FTE is budgeted in the Capital Funds



Parks, Recreation and Cultural Services (PRCS) 2007 Budget

2007 PRCS Department as a Share of the General Fund

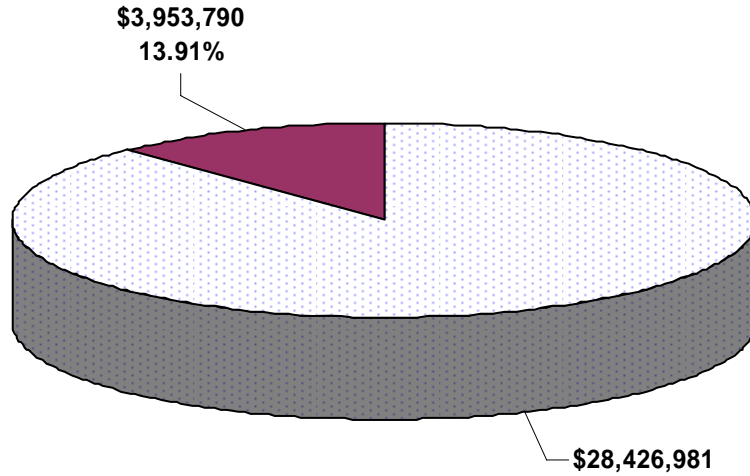

PRCS Historical Comparison

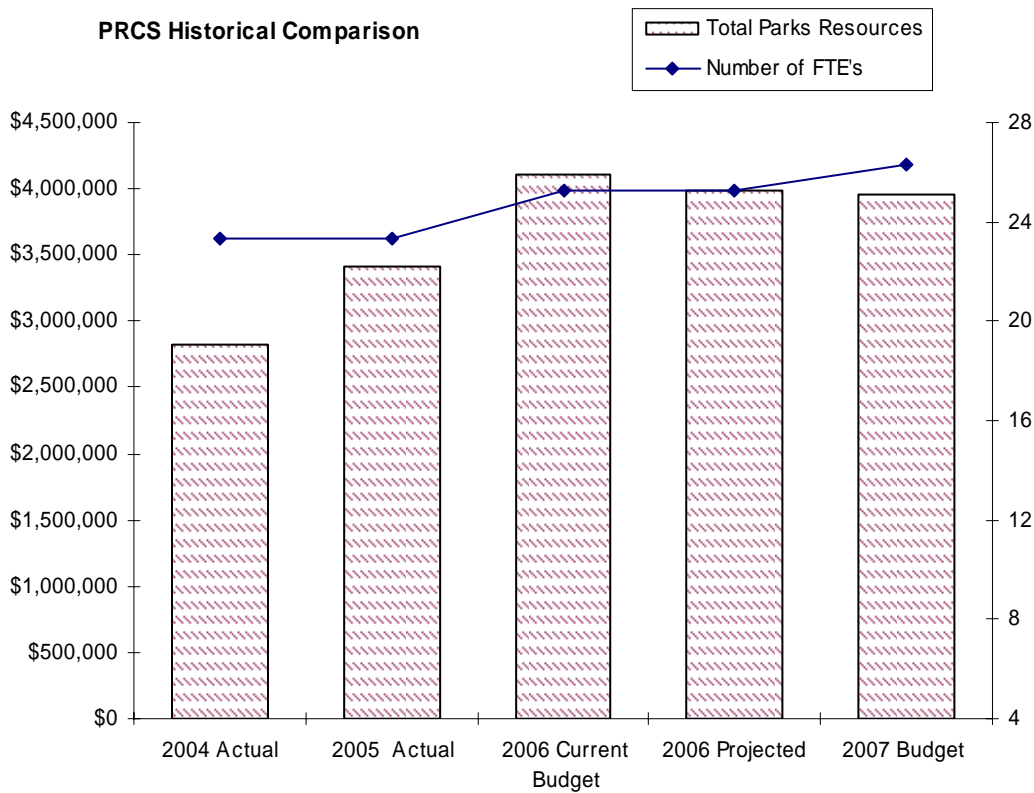



Parks, Recreation and Cultural Services (PRCS) 2007 Budget

2006 Key Department Accomplishments in Support of the City's Strategic Objectives:

Quality Services, Facilities and Infrastructure

- Parks Bond Issue Package approved by voters.
- Completed construction of new synthetic turf fields at Shoreline A and B.
- RBSW Park master planning process completed.
- Refurbish all picnic tables and benches within park system.
- Installed covers for dugouts at Shoreview Park.
- Park Signage Design Completed.
- Increased attendance at the REC by 529 participants from last years first 6 months and increased attendance at the Center (Late Night Teen Center) by 825 participants from last years first 6 months.
- Installed new heavy duty (600 lbs entry stairs into the shallow end to allow patrons easier access to pool. We also placed stairs in a different location to optimize shallow pool area for lessons and exercise classes.
- Renewed School District Joint Use Agreement.
- Continued partnership with Shoreline-Lake Forest Park Arts Council and Shoreline Historical Museum.
- Over 23,000 projected rental hours used by Parks customers in 2006 and over 425,000 projected attendance for those rentals.
- Increased overall course registration for Aquatics to the highest ever lesson registration (especially in our Summer registration)
- Scheduled and assisted in the planning of several large events in City Parks: Easter Egg Hunt at Richmond Beach, Sunrise Service at Richmond Beach, Little League Jamborees at Richmond Highlands and Hamlin Park, Fly Fishing Clinic at Richmond Beach, Special Olympics Softball Tournament at Hamlin Park, Dog Disc Event at Hamlin Park, and the Strawberry Festival at Richmond Beach Community Park.

Safe, Healthy and Sustainable Environment

- Urban Forestry Management Plan Underway.
- Coordinated a successful community event "Ivy Out Program"

Safe and Attractive Neighborhoods and Business Districts

- Off-leash contract with King Co. Animal Control with 200+ contacts made.
- Established Boys to Men, a leadership group for young men. The intention of the group is to help young men learn to make healthier and safer life choices through participating in recreational activities.
- Established a new leadership group whose members are regular REC drop-in participants called OYE! Open Your Eyes! This group focuses on diversity



Parks, Recreation and Cultural Services (PRCS) 2007 Budget

awareness and education. Their intention is to learn about issues on a global and national level and then transfer that knowledge to action in their local community.

- Partnered with Starbucks and Echo Lake Neighborhood Association to host a joint park maintenance event at Echo Lake Park.

Human Services

- Increased the level of scholarships to low-income youth to participate in recreation programs.

2007 Key Department Objectives in Support of the City's Strategic Objectives:

Quality Services, Facilities and Infrastructure

- Richmond Beach Salt Water Park Construction begins.
- Cromwell Park Master Plan.
- Complete 2006 parks bond projects: acquire properties; complete master plans; construct improvements
- The Repair and Replacement budget has been increased to upgrade aging facilities acquired from King County.
- Further develop a working relationship with 4Culture to assist in managing public art opportunities. A long range art opportunities plan will be developed for Aurora and the Interurban Trail

Safe and Attractive Neighborhoods and Business Districts

- Coordinated emergency preparedness trainings to Teen staff and volunteers - adult and high school community service volunteers.
- Increase awareness focusing on Alcohol and other drugs. (via Empowering Youth Everywhere – the leadership group known as EYE).
- Provide education to teens about violence and violence prevention.
- Offer opportunities of learning about other cultures to counteract ignorance and neutralize hate related crimes.
- Implement an “adopt-a-park and trail” program



Parks, Recreation and Cultural Services (PRCS) 2007 Budget

Parks, Recreational & Cultural Services 2004 - 2007 Program Comparison By Program							
Expenditures By Program	2006 Current					2006 Current Budget versus 2007 Budget	Percentage Change
	2004 Actual	2005 Actual	Budget	2006 Projected	2007 Budget		
Administration	\$238,179	\$292,593	\$391,923	\$397,635	\$406,930	\$15,007	3.83%
Athletic Field Maintenance & Operations	\$191,401	\$226,005	\$289,051	\$272,840	\$273,349	-\$15,702	-5.43%
Park & Open Space	\$674,055	\$823,422	\$1,168,349	\$1,072,265	\$1,059,999	-\$108,350	-9.27%
Aquatics	\$506,070	\$738,136	\$758,057	\$745,053	\$792,939	\$34,882	4.60%
Recreation Facility Rental	\$24,150	\$26,899	\$27,624	\$27,872	\$28,764	\$1,140	4.13%
General Recreation Programs	\$639,565	\$695,327	\$764,512	\$767,661	\$779,089	\$14,577	1.91%
Teen Recreation Programs*	\$325,072	\$337,187	\$366,155	\$367,292	\$381,274	\$15,119	4.13%
Parks Cultural Services Programs	\$231,231	\$253,879	\$219,454	\$221,846	\$231,446	\$11,992	5.46%
Public Arts	\$0	\$15,000	\$115,775	\$115,775	\$0	-\$115,775	-100.00%
Total Expenditure	\$2,829,723	\$3,408,448	\$4,100,900	\$3,988,239	\$3,953,790	-\$147,110	-3.59%
Revenue By Program							
Administration	\$0	\$468	\$0	\$0	\$0	\$0	0.00%
Athletic Field Maintenance & Operations	\$136,019	\$46,871	\$165,008	\$161,025	\$183,101	\$18,093	10.96%
Park & Open Space	\$9,916	-\$17,996	\$27,775	\$11,811	\$38,825	\$11,050	39.78%
Aquatics	\$329,464	\$351,507	\$348,497	\$358,051	\$354,050	\$5,553	1.59%
Recreation Facility Rental	\$44,838	\$150,142	\$53,368	\$55,759	\$58,750	\$5,382	10.08%
General Recreation Programs	\$270,937	\$400,386	\$363,700	\$489,134	\$508,182	\$144,482	39.73%
Teen Recreation Programs	\$37,962	\$33,161	\$38,169	\$40,625	\$39,056	\$887	2.32%
Parks Cultural Services Programs	\$9,681	\$17,976	\$15,000	\$12,400	\$22,000	\$7,000	46.67%
Public Arts		\$232,827	\$149,667	\$49,148	\$0	-\$149,667	(100.00%)
Total Operations Revenue	\$838,817	\$1,215,342	\$1,161,184	\$1,177,953	\$1,203,964	\$42,780	3.68%
General Fund Subsidy	\$1,990,906	\$2,193,106	\$2,939,716	\$2,810,286	\$2,749,826	-\$189,890	-6.46%
Total Resources	\$2,829,723	\$3,408,448	\$4,100,900	\$3,988,239	\$3,953,790	-\$147,110	-3.59%

* The total cost of the Teen Program for 2007 is \$418,219. The remaining \$36,945 can be found in the Police Department. This is for police overtime to participate in teen evening recreational programs. Additional revenue sources for this program can also be found in the Police Department budget.

2007 PRCS Program Breakdown

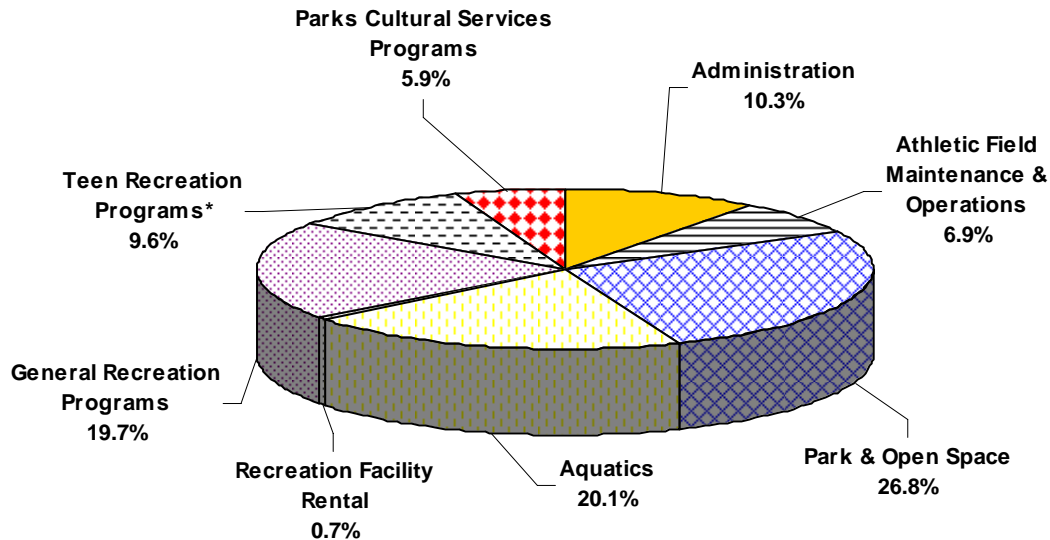



Parks, Recreation and Cultural Services (PRCS) 2007 Budget

Parks, Recreational & Cultural Services 2004 - 2007 Budget Comparison By Object							
Object Category Name	2004 Actual	2005 Actual	2006 Current Budget	2006 Projected	2007 Budget	2006 Current Budget versus 2007 Budget	Percentage Change
Salary	\$1,457,843	\$1,594,097	\$1,795,233	\$1,745,242	\$1,925,842	\$130,609	7.28%
Benefits	\$386,049	\$423,702	\$482,972	\$481,485	\$574,331	\$91,359	18.92%
Supplies	\$155,633	\$192,526	\$163,294	\$165,773	\$201,224	\$37,930	23.23%
Other Services & Charges	\$758,584	\$1,143,576	\$1,370,219	\$1,305,708	\$1,153,790	-\$216,429	-15.80%
Intergovernmental Services	\$29,029	\$11,715	\$8,000	\$7,500	\$8,000	\$0	0.00%
Capital Outlays	\$7,394	\$1,442	\$228,426	\$229,775	\$16,500	-\$211,926	0.00%
Interfund Payments for Service	\$35,191	\$41,390	\$52,756	\$52,756	\$74,103	\$21,347	40.46%
Total Parks Expenditures	\$2,829,723	\$3,408,448	\$4,100,900	\$3,988,239	\$3,953,790	-\$147,110	-3.59%
Revenue							
Budgeted Beginning Fund Balance	\$0	\$0	\$115,775	\$0	\$0	\$0	0.0%
Licenses and Permits	\$7,954	\$3,766	\$8,800	\$200	\$8,800	\$0	0.00%
Intergovernmental Revenues	\$32,925	\$27,141	\$29,069	\$38,333	\$40,338	\$11,269	38.77%
Charges for Goods and Services	\$771,393	\$925,271	\$928,132	\$1,030,505	\$1,096,350	\$168,218	18.12%
Fines	\$181	\$0	\$0	\$0	\$0	\$0	0.00%
Miscellaneous Revenues	\$26,364	\$27,557	\$45,516	\$75,023	\$58,476	\$12,960	28.47%
Other Financing Sources	\$37,602	\$231,607	\$33,892	\$33,892	\$0	-\$33,892	-100.00%
Total Parks Revenue	\$876,419	\$1,215,342	\$1,161,184	\$1,177,953	\$1,203,964	\$42,780	3.68%
General Fund Subsidy	\$1,953,304	\$2,193,106	\$2,939,716	\$2,810,286	\$2,749,826	-\$189,890	-6.46%
Total Parks Resources	\$2,829,723	\$3,408,448	\$4,100,900	\$3,988,239	\$3,953,790	-\$147,110	-3.59%
Department Statistics							
% of General Fund	11.7%	11.6%	13.9%	13.6%	13.9%	(0.04%)	-0.3%
Number of FTE's	23.3	23.3	25.30	25.30	26.30	1.00	4.0%

Parks, Recreational & Cultural Services 2004 - 2007 by Fund							
Expenditures By Program	2004 Actual	2005 Actual	2006 Current Budget	2006 Projected	2007 Budget	2006 Current Budget versus 2007 Budget	Percentage Change
General Fund	\$2,829,723	\$3,393,448	\$3,985,125	\$3,872,464	\$3,953,790	-\$31,335	-0.79%
Public Arts Projects	\$0	\$15,000	\$115,775	\$115,775	\$0	-\$115,775	-100.00%
Total Parks Budget	\$2,829,723	\$3,408,448	\$4,100,900	\$3,988,239	\$3,953,790	-\$147,110	-3.59%



Parks, Recreation and Cultural Services (PRCS) 2007 Budget

2007 Budget Highlights

- The proposed budget includes the addition of a Parks Maintenance Worker II position and some additional extra help hours. This position will take over work previously performed by the City's maintenance contractor. Specifically the City is moving all of the athletic field prep work in-house. It was determined that the City with the new position and extra-help hours could perform this work more effectively and efficiently than the private landscape contractor. The cost breakdown of this shift is the City will increase in-house costs by \$117,200 (salaries, benefits and supplies) and decrease contract maintenance costs by \$146,078 with a net 2007 cost savings to the City of \$24,377. The Parks Operations budget includes \$16,500 as one-time dollars for the purchase of a truck for this position. The truck is budgeted in capital outlay.
- \$4,000 that had been budgeted within the supplies category of the Administration program was shifted to the services category to cover the increased cost of producing the Parks Recreation Guide.
- The 2006 Parks Operations budget included \$119,151 in one-time expenses that were not carried over to the 2007 budget. Two items were budgeted in professional services and totaled \$85,000. These items were for park signage, and the urban forestry assessment. A third item was a maintenance truck that was budgeted in capital outlay for \$34,151.
- The 2007 Parks Operations budget for water was reduced by \$50,000 for 2007. This is based on the water usage for 2006.
- The 2007 Aquatics budget for natural gas was increased by \$11,550 to accommodate natural gas rate increases.
- The 2006 Parks General Recreation Programs budget included \$62,000 for the purchase of a handicap accessible van. This was considered a one-time expense and was not carried forward to 2007.
- The 2007 contribution to the Shoreline Museum and the Arts Council are each budgeted at \$63,526 for a total of \$127,052. This is a \$3,094 overall increase from the 2006 budget.

PARKS ADMINISTRATION

PROGRAM PURPOSE:

Administer a full service Parks, Recreation and Cultural Services Department and provide long term planning and capital project oversight of park projects to support community use and meet public recreation needs of the community and provides support to the Shoreline Library Board.

STRATEGIC OBJECTIVES:

Quality Services, Facilities and Infrastructure

Measurement: EFFECTIVENESS	2004	2005	2006	2007/Target
Park acreage per thousand population	6.78	6.78		
Percentage of citizens satisfied with Parks, Recreation and Cultural Services	88%	88%		
Percentage of Community that has visited a park in the past year	70%	70%		
Percentage of Community that has visited a park more than five times in the past year	66%	66%		

Measurement: EFFICIENCY	2004	2005	2006	2007/Target
Net Parks and Recreation revenue per capita	\$40.65	\$48.82		
Parks Administration as a percent of the total Parks budget	8.4%	9%		
Parks and Recreation FTE per 1.000 population	.44	.44		
Recreation and athletic programming cost recovery percentage	40%	42%		

Measurement: OTHER	2004	2005	2006	2007/Target
Number of volunteer hours	2,718.9	1,979		

PARKS ADMINISTRATION

2006

Program Expenditures	\$	391,923
Program Revenue	\$	-
General Support	\$	391,923

Program Revenue vs General Support

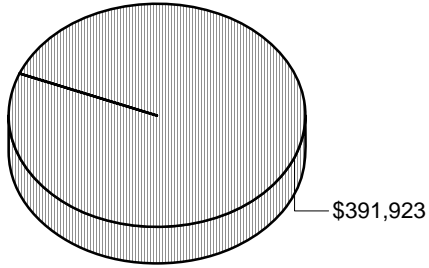

<input checked="" type="checkbox"/> @Support	100.0%
<input type="checkbox"/> @Revenue	0.0%
<hr style="width: 100%;"/>	
Total:	100.0%

2007

Program Expenditures	\$	406,930
Program Revenue	\$	-
General Support	\$	406,930

Program Revenue vs General Support

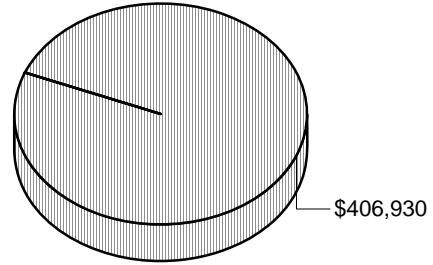

<input checked="" type="checkbox"/> @Support	100.0%
<input type="checkbox"/> @Revenue	0.0%
<hr style="width: 100%;"/>	
Total:	100.0%

ATHLETIC FIELD MAINTENANCE & OPERATIONS

PROGRAM PURPOSE:

Provide stewardship for the City's athletic fields and to create safe recreational opportunities for the well-being and enjoyment of the public.

STRATEGIC OBJECTIVES:

Quality Services, Facilities and Infrastructure

Measurement: EFFICIENCY	2004	2005	2006	2007/Target
Program Revenue as a percent of program expense	48%	47%	67.1%	67%

Measurement: WORKLOAD	2004	2005	2006	2007/Target
Number of baseball fields	15	15	15	15
Number of baseball/soccer game field preps provided	1,222	1,297	1,301	1,312
Number of baseball/soccer practice field preps provided	1,317	1,326	1,330	1,340
Number of hours of adult field rentals	9,721	4,281	4,382	5,000
Number of hours of youth field rentals	14,582	14,267	12,268	14,275
Number of soccer fields	10	10	10	10

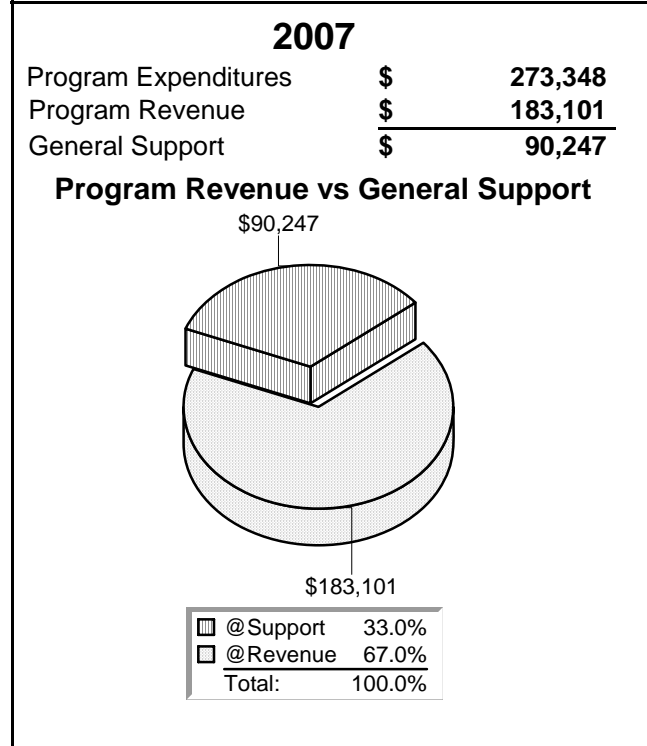
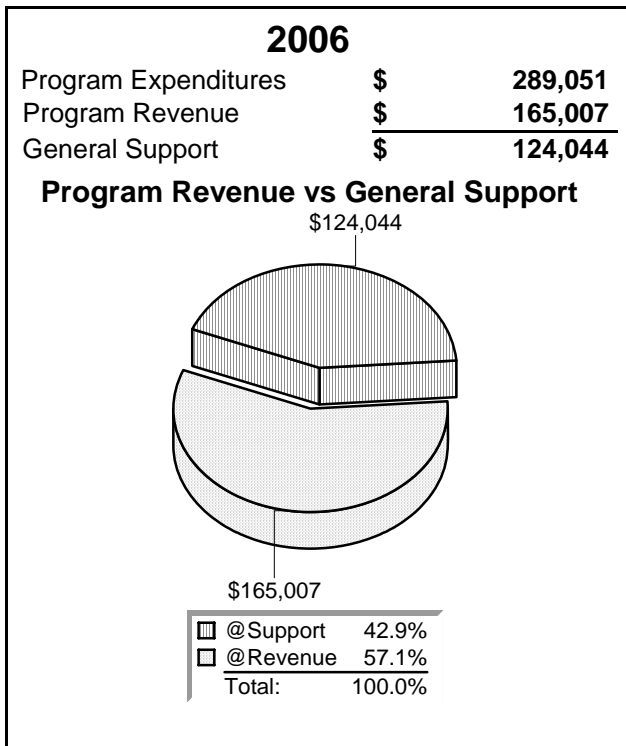

PARK AND OPEN SPACE MAINTENANCE PROGRAM

PROGRAM PURPOSE:

Provide stewardship for the City's parks and open space system, including the preservation of important natural areas, the enhancement of quality parks, and to create safe recreational and educational opportunities for the well-being and enjoyment of the public.

STRATEGIC OBJECTIVES:

Quality Services, Facilities and Infrastructure

Measurement: EFFICIENCY	2004	2005	2006	2007/Target
Average Annual cost per acre of park property maintained	\$2,840	\$4,300	\$4,300	\$3,940

Measurement: OTHER	2004	2005	2006	2007/Target
Total Cost of Contracted Maintenance Services	\$347,580	\$516,547	\$456,204	\$306,204

Measurement: WORKLOAD	2004	2005	2006	2007/Target
Number of acres of park and open space maintained	353	356	356	381

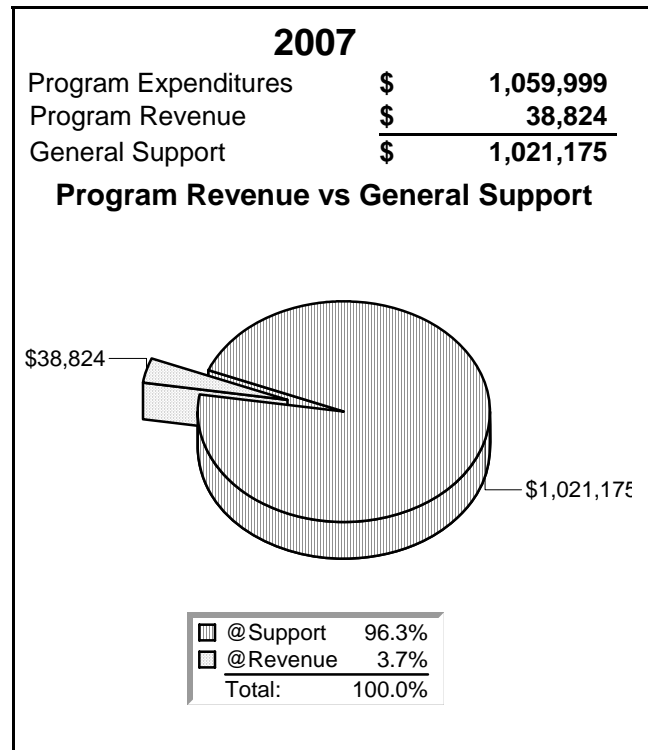
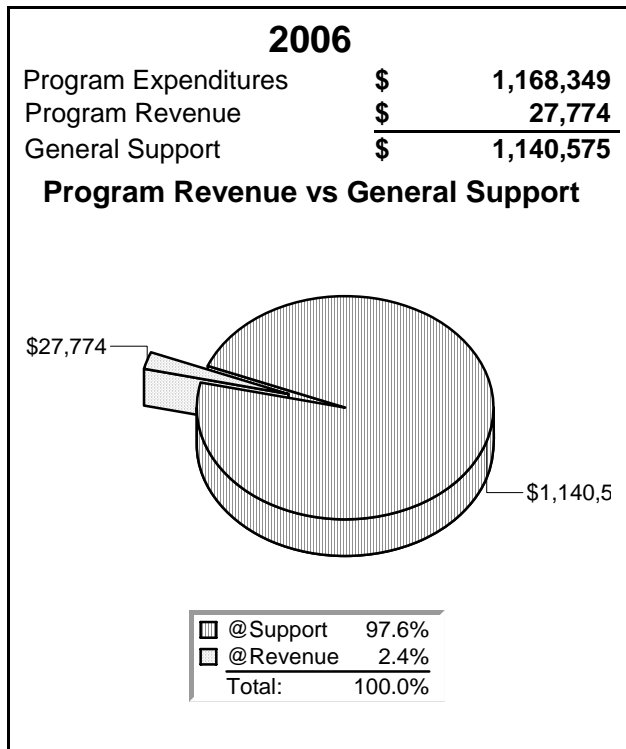

AQUATICS

PROGRAM PURPOSE:

Provide safe, healthy, accessible and affordable programs and services for the Shoreline community.
 Provide diverse, life-long activities that meet evolving community needs in the areas of water safety, swimming skills, athletics, health, fitness, psychological well-being, certifications and recreational aquatics.

STRATEGIC OBJECTIVES:

Quality Services, Facilities and Infrastructure

Measurement: EFFICIENCY	2004	2005	2006	2007/Target
Drop-in participants per hour of drop-in opportunity.	19.4	20.4	N/A	
Program Revenue as a percentage of program costs (added utilities in 2005).	53.1%	49.1%	46%	44.7%
Revenue per hour of Shoreline Pool operation	\$65.66	\$67.51	\$70.56	

Measurement: WORKLOAD	2004	2005	2006	2007/Target
Number of course participants	4,819	4,710	4,815	4,815
Number of drop-in participants	50,346	47,276	47,460	50,000
Number of hours of course instruction	4,488	4,730	4,857	4,857
Number of hours of drop-in opportunities (Lap & Rec Swim)	2,589	2,589	2,589	2,589
Number of pool rental hours.	4,129	4,539	4,150	4,500
Resident Course Participants		85.8%		
Total Number of hours of pool operation	5,018	5,018	5,018	5,018

AQUATICS

2006

Program Expenditures	\$	758,057
Program Revenue	\$	348,497
General Support	\$	409,560

Program Revenue vs General Support

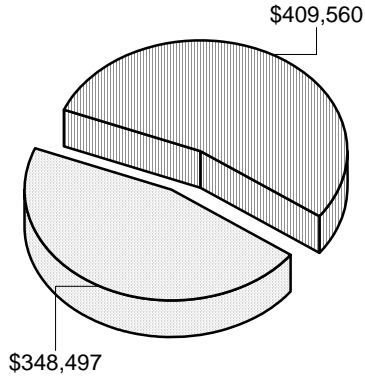

@Support	54.0%
@Revenue	46.0%
Total:	100.0%

2007

Program Expenditures	\$	792,939
Program Revenue	\$	354,050
General Support	\$	438,889

Program Revenue vs General Support

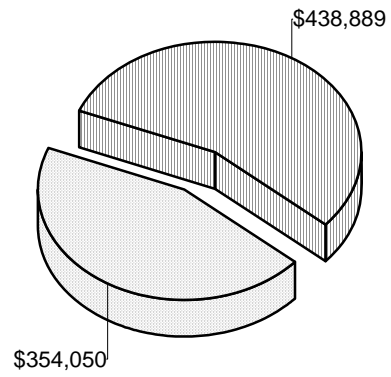

@Support	55.3%
@Revenue	44.7%
Total:	100.0%

RECREATION FACILITY RENTAL PROGRAM

PROGRAM PURPOSE:

Provide opportunities for Shoreline residents to use recreational facilities and picnic shelters for special events.

STRATEGIC OBJECTIVES:

Quality Services, Facilities and Infrastructure

Measurement: WORKLOAD	2004	2005	2006	2007/Target
Hours of Baseball/Softball Field Rentals		9,730	10,248	10,350
Hours of Football Field Rentals		635	987	1,000
Hours of Picnic Shelter Rentals		1,292	1,475	1,500
Hours of Rentals of Richmond Highlands Recreation Center		485	490	500
Hours of Rentals of Spartan Recreation Center		2,788	2,992	3,000
Hours of Soccer Field Rentals		7,232	6,230	7,250
Total Hours of facility rentals	8,093	22,162	22,422	23,600

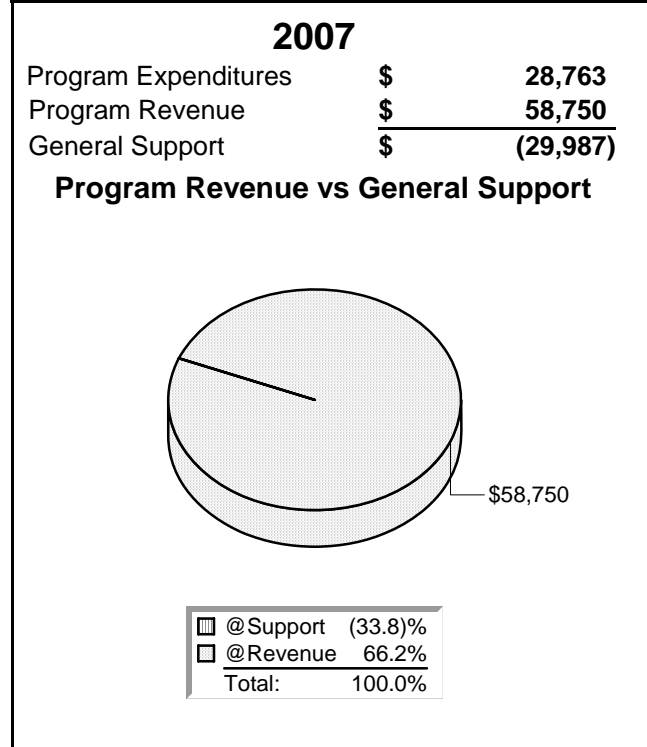
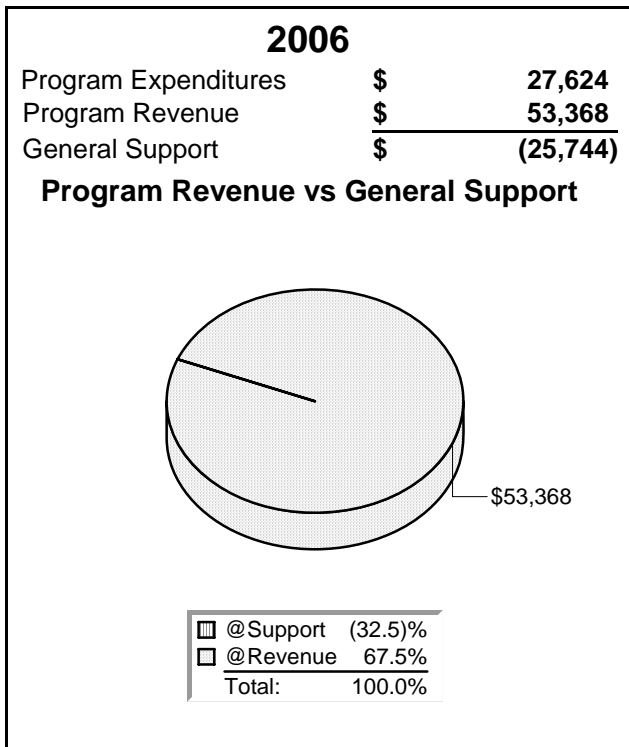

GENERAL RECREATION PROGRAMS

PROGRAM PURPOSE:

Develop and implement comprehensive recreation programs, services, and events targeting all ages and abilities, and a variety of special interests throughout the year to meet the needs of the community.

STRATEGIC OBJECTIVES:

Quality Services, Facilities and Infrastructure

Measurement: EFFECTIVENESS	2004	2005	2006	2007/Target
Percentage of class sessions, ie pre-ballet has 10 sessions = 10 classes, that were held that were offered		73%	75%	75%
Percentage of customers rating the quality of the programs as good or excellent	94%	94%	95%	100%
Percentage of residents who participated in recreational programming offered by the City	67%	73%	70%	70%

Measurement: EFFICIENCY	2004	2005	2006	2007/Target
Average Number of Participants per Day	N/A	376	500	500
Percent of general recreation program budget supported by fees.	42.4%	51.5%	47.6%	65.2%

Measurement: WORKLOAD	2004	2005	2006	2007/Target
Number of adult participants	17,059	19,211	20,000	
Number of adult recreational classes held	307	256	300	
Number of preschool participants	7,070	8,698	9,500	
Number of preschool recreational classes held	81	99	100	
Number of youth participants	2,743	3,319	5,000	
Number of youth recreational classes held	163	252	350	

GENERAL RECREATION PROGRAMS

2006

Program Expenditures	\$	764,511
Program Revenue	\$	363,700
General Support	\$	400,811

Program Revenue vs General Support

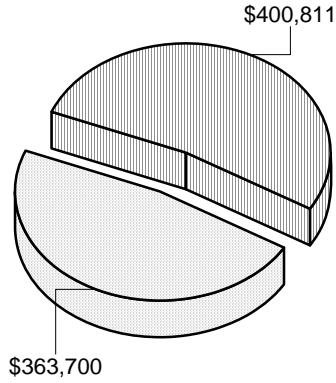

@Support	52.4%
@Revenue	47.6%
Total:	100.0%

2007

Program Expenditures	\$	779,088
Program Revenue	\$	508,182
General Support	\$	270,906

Program Revenue vs General Support

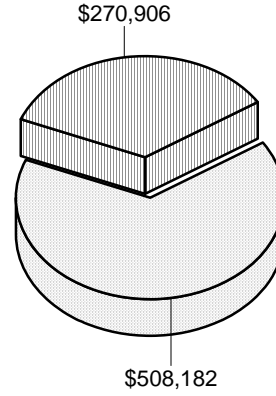

@Support	34.8%
@Revenue	65.2%
Total:	100.0%

TEEN RECREATION PROGRAMS

PROGRAM PURPOSE:

The Teen Recreation program help youth in the community, ages 12-19 years old, make successful life choices by being positive role models and offering diverse, challenging, safe and innovative programs. As a means of gauging progress toward this goal, the program uses 9 of the 40 Search Institute's Development Assets for success as guiding factors. The assets chosen focus on the following: giving teens useful roles, valuing their opinions, giving clear expectations, doing their homework, volunteerism, increasing their sense of personal responsibility, non-violent conflict resolution, adding more caring adults in their lives and helping them feel more in control over their life.

STRATEGIC OBJECTIVES:

Quality Services, Facilities and Infrastructure

Measurement: EFFECTIVENESS	2004	2005	2006	2007/Target
Percentage of surveyed participants that always or sometimes feel that the Teen Program provides all 9 of the development assets	82%	82%	83%	84%

Measurement: EFFICIENCY	2004	2005	2006	2007/Target
Net cost per hour of teen recreation programs (net of revenue)	\$99.56	\$130.09	\$125.62	
Net Cost per Visit (net of revenues)	\$8.51	\$11.76	\$11.06	\$11.06

Measurement: WORKLOAD	2004	2005	2006	2007/Target
Number of teen recreation program hours	3,197	2,719	2,847	2,800
Number of visits in the Teen Late Night Programs	11,507	8,977	9,250	9,200
Number of visits to all Teen Programs excluding Late Night	22,213	22,561	22,818	23,000
Total number of all visits.	33,720	31,538	32,068	32,200

TEEN RECREATION PROGRAMS

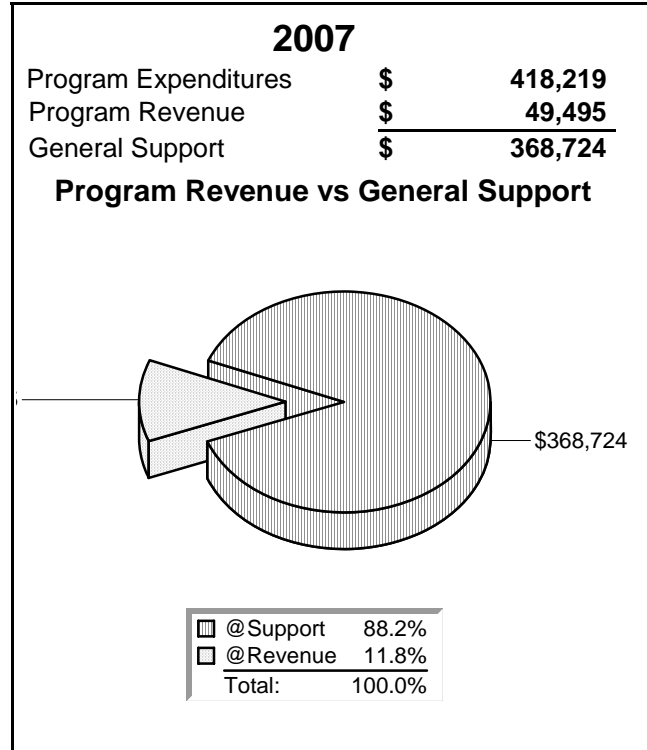
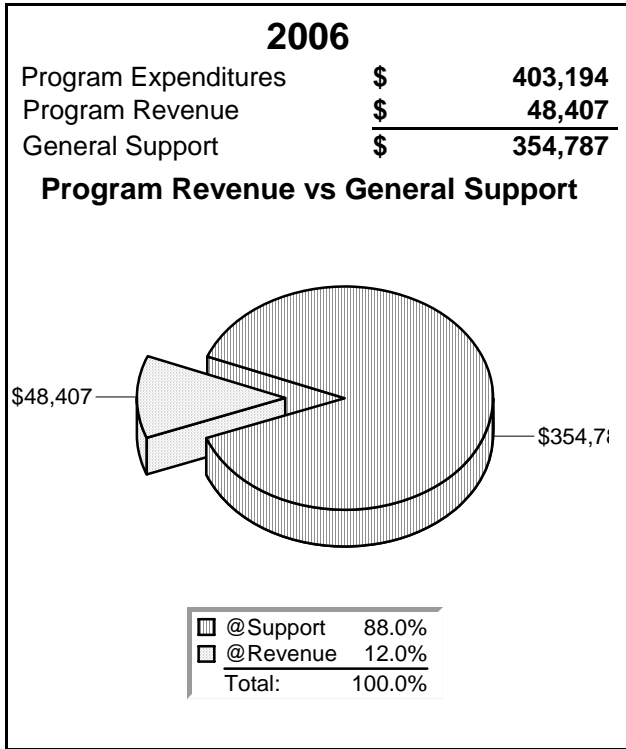

PARKS CULTURAL SERVICES PROGRAMS

PROGRAM PURPOSE:

The Parks Cultural Services Program provides a variety of community services and events: Celebrate Shoreline, Summer Lunchtime Music Series, Swingin' Summer Eve, Hamlin Haunt, Fall Library programs, and financial contributions to the Arts Council and Shoreline Museum.

STRATEGIC OBJECTIVES:

Quality Services, Facilities and Infrastructure

Measurement: EFFICIENCY	2004	2005	2006	2007/Target
Shoreline Historical Museum contribution per capita	\$1.17	\$1.18	\$1.18	
Shoreline/Lake Forest Park Arts Council contribution per capita	\$1.17	\$1.18	\$1.18	

Measurement: OTHER	2004	2005	2006	2007/Target
Amount of sponsorship dollars for Celebrate Shoreline	\$6,200	\$6,350	\$6,150	\$6,000
Total Cost for Swingin' Summer Eve Events	\$400	\$400	\$400	\$400
Total Cost of Fall Library Program	\$1,200	\$1,200	\$1,200	\$1,200
Total Cost of Hamlin Haunt	\$800	\$800	\$800	\$800
Total Cost of Summer Lunchtime Events	\$3,000	\$3,000	\$3,000	\$3,000

Measurement: WORKLOAD	2004	2005	2006	2007/Target
Fall library program participants	145	150	150	150
Hamlin Haunt attendance	800	1,000	1,000	1,000
Number of Events Held During Celebrate Shoreline, Teen Event, Parade, Festival and Sand Castle Contest		4	4	4
Number of fall library programs	6	6	4	4
Number of Sponsors of Celebrate Shoreline Events	20	18	14	15
Number of summer lunchtime events	6	6	6	6
Summer lunchtime event attendance	2,000	2,000	2,200	2,400
Swingin' Summer Eve attendance	1,000	1,000	800	800

PARKS CULTURAL SERVICES PROGRAMS

2006

Program Expenditures	\$	219,454
Program Revenue	\$	15,000
General Support	\$	204,454

Program Revenue vs General Support

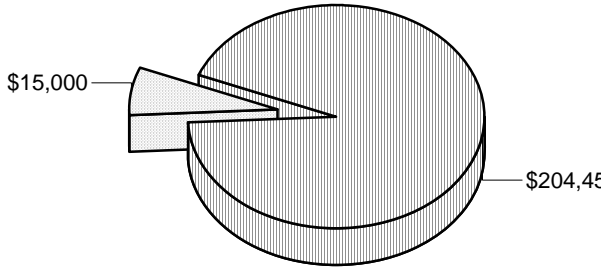

<input type="checkbox"/> @Support	93.2%
<input type="checkbox"/> @Revenue	6.8%
<hr style="border: none; border-top: 1px solid black;"/>	
Total:	100.0%

2007

Program Expenditures	\$	231,445
Program Revenue	\$	22,000
General Support	\$	209,445

Program Revenue vs General Support

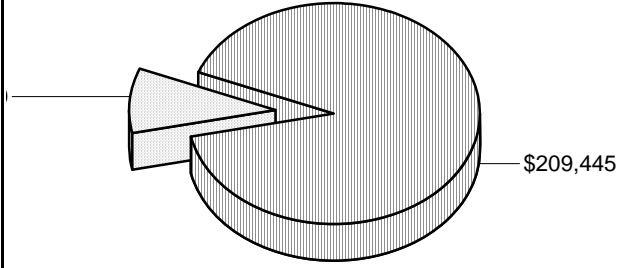

<input type="checkbox"/> @Support	90.5%
<input type="checkbox"/> @Revenue	9.5%
<hr style="border: none; border-top: 1px solid black;"/>	
Total:	100.0%



Planning & Development Services



Planning and Development Services 2007 Budget

Mission Statement

“Our mission is to ensure that the natural and built environments are healthy, safe, and reflect the community’s vision by providing exceptional customer service, listening to our customers and citizens, and proactively solving problems.”

Department Programs

Code Enforcement

1.65 FTE

Operational Support Team

2.60 FTE

Long Range Planning Team

3.35 FTE

Current Planning Team

4.70 FTE

Permit Services Team

9.15 FTE

Building & Inspection Team

6.05 FTE

*An Additional PADS 1.0 FTE is budgeted
in the Capital Funds



Planning and Development Services 2007 Budget

**2007 PADS General Fund Portion as a Share of
the General Fund**

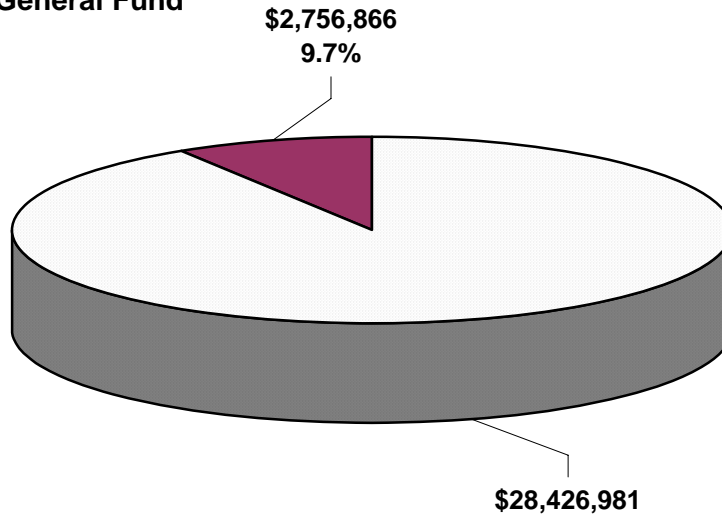

PADS Historical Comparison

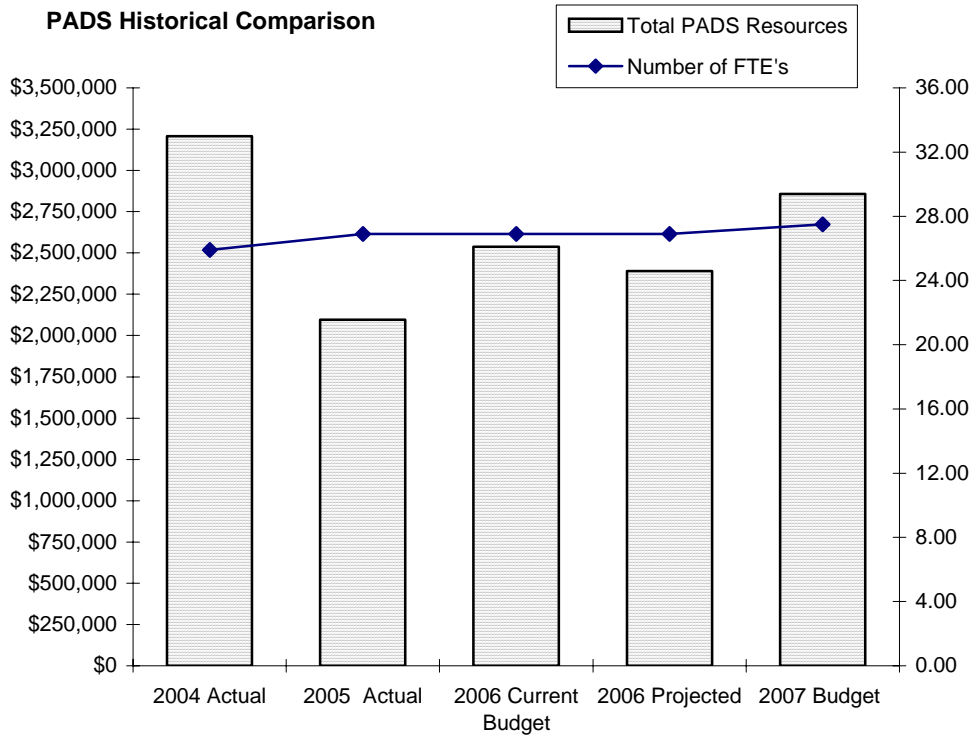



Planning and Development Services 2007 Budget

2006 Key Department Accomplishments in Support of the City's Strategic Objectives:

Safe and Attractive Neighborhoods and Business Districts

- Adopted the Critical Areas Ordinance No. 398
- Developed permanent hazardous tree regulations in conjunction with community groups. Council adopted Ordinance No. 434
- Closed 42 code enforcement cases
- Enhanced the civil plan review process to ensure consistency in standards and to provide for public streets and drainage facilities that are durable and maintained
- Actively participated in Project Impact. Rewrote "How to Complete an Earthquake Retrofit Plan" booklet

Quality Services, Facilities and Infrastructure

- Implemented the electrical permitting program
- Analyzed workflow of the Development Review Engineer position and determined that additional staff resources were required to provide an acceptable level of service and adjusted the methodology to accurately reflect the costs associated with these permit reviews

Governmental Excellence

- Conducted a retreat to work on strategic plans to improve communication and coordination with internal and external customers

Economic Vitality and Financial Stability

- Reviewed and coordinated Aurora commercial development with street improvement plans for McDonalds, South Echo Lake, Discount Tires, Watermark Credit Union, Walgreens, Gateway Plaza, South Wedge, and Shurgard Storage

Effective Citizen Communication and Engagement

- Amended the neighborhood meeting requirements in the Development Code to enhance public comment opportunities
- Revised department web site to improve public access to information handouts, application forms, and submittal checklists



Planning and Development Services 2007 Budget

2007 Key Department Objectives in Support of the City's Strategic Objectives:

Safe and Attractive Neighborhoods and Business Districts

- Develop a comprehensive housing strategy in partnership with the community that responds to Shoreline's changing demographics
- Actively participate in Project Impact (seismic retrofit of existing housing and commercial structures)
- Actively participate in disaster preparedness training, exercises, and hazard mitigation implementation
- Implement the Economic Development Strategic Plan by considering form based codes
- Develop regulations that encourage focused redevelopment of Ridgecrest commercial area
- Improve code enforcement program
- Review IBC interior property maintenance codes

Safe, Healthy, and Sustainable Environment

- Review and consider adoption of an updated surface water design manual as part of developing an environmentally sustainable community
- Develop a natural systems strategic plan in coordination with Public Works and Parks
- Complete and implement Natural Resources Management Plan
- Complete Town Center Plan
- Initiate Ballinger Special Study Area Plan
- Complete Fircrest master plan

Governmental Excellence

- Complete critical areas tree update

Economic Vitality and Financial Stability

- Facilitate planning for "wedges" properties

Human Services

- Complete Comprehensive Housing Strategy
- Complete senior housing strategy



Planning and Development Services 2007 Budget

Planning & Development Services 2004 - 2007 Budget Comparison By Program							
Program Budget	2006 Current					2006 Current	Percentage Change
	2004 Actual	2005 Actual	Budget	2006 Projected	2007 Budget	Budget versus 2007 Budget	
Code Enforcement Team*	\$111,505	\$134,174	\$152,349	\$147,364	\$170,522	\$18,173	11.93%
Building & Inspections Team	\$988,500	\$577,291	\$728,774	\$634,496	\$752,182	\$23,408	3.21%
Permit Services Team	\$528	\$501,484	\$677,027	\$674,409	\$718,932	\$41,905	6.19%
Planning - Long Range Team	\$366,550	\$303,372	\$272,488	\$253,915	\$322,220	\$49,732	18.25%
Planning & Development Services Support Team	\$423,604	\$217,704	\$235,894	\$231,524	\$252,625	\$16,731	7.09%
Current Planning Team	\$1,975	\$342,625	\$370,266	\$349,089	\$540,385	\$170,119	45.95%
Code Abatement	\$19,729	\$19,717	\$100,000	\$100,000	\$100,000	\$0	0.00%
<i>Ongoing Programs</i>	\$499,424	\$0	\$0	\$0	\$0	NA	NA
<i>P&DS Projects</i>	\$93,608	\$0	\$0	\$0	\$0	NA	NA
Non-Program Specific Transfers to Other Funds	\$702,622	\$0	\$0	\$0	\$0	\$0	0.00%
Total Program Budget	\$3,208,045	\$2,096,367	\$2,536,798	\$2,390,797	\$2,856,866	\$320,068	12.62%
*The Code Enforcement Program is also supported by the Customer Response Team.							
Program Revenue							
Code Enforcement Team*	\$0	\$0	\$0	\$0	\$0	\$0	0.00%
Building & Inspections Team	\$516,064	\$719,474	\$722,735	\$684,719	\$704,390	-\$18,345	-2.54%
Permit Services Team	\$256,944	\$358,515	\$340,900	\$332,141	\$332,945	-\$7,955	0.00%
Planning - Long Range Team	\$81,074	\$53,682	\$49,250	\$53,738	\$52,250	\$3,000	0.00%
Planning & Development Services Support Team	\$0	\$16,100	\$0	\$0	\$0	\$0	0.00%
Current Planning Team	\$197,286	\$205,783	\$190,750	\$210,166	\$202,750	\$12,000	0.00%
Code Abatement	\$15,778	\$9,372	\$82,500	\$29,212	\$82,500	\$0	0.00%
<i>Ongoing Programs</i>	\$0	\$0	\$0	\$0	\$0	NA	NA
<i>P&DS Projects</i>	\$0	\$0	\$0	\$0	\$0	NA	NA
Non-Program Specific Misc. Revenue	\$0	\$30,940	\$0	\$0	\$0	\$0	0.00%
Total Program Revenue	\$1,067,146	\$1,393,866	\$1,386,135	\$1,309,975	\$1,374,835	-\$11,300	-0.82%
General Fund Subsidy	\$2,140,899	\$702,501	\$1,150,663	\$1,080,822	\$1,464,531	\$331,368	28.80%
Use of Code Abatement Fund Balance	\$0	\$0	\$0	\$0	\$17,500	-\$17,500	0.00%
Total Resources	\$3,208,045	\$2,096,367	\$2,536,798	\$2,390,797	\$2,856,866	\$320,068	12.62%

*Total program costs for Code Enforcement are \$465,790 for 2007. The remaining \$295,268 is in the Customer Response Team department.

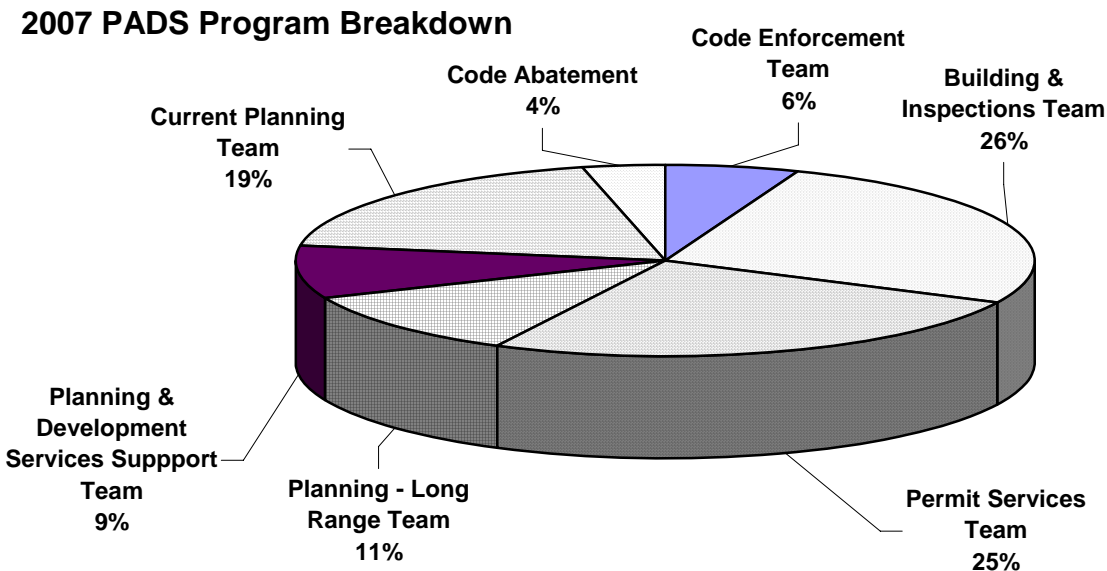



Planning and Development Services 2007 Budget

Planning & Development Services 2004 - 2007 Budget Comparison By Object							
Object Category Name	2006 Current					2006 Current Budget versus 2007 Budget	Percentage Change
	2004 Actual	2005 Actual	Budget	2006 Projected	2007 Budget		
Salary	\$1,747,582	\$1,420,795	\$1,655,883	\$1,545,414	\$1,773,928	\$118,045	7.13%
Benefits	\$463,132	\$379,095	\$465,026	\$450,206	\$556,555	\$91,529	19.68%
Supplies	\$30,417	\$16,051	\$25,385	\$17,819	\$22,211	-\$3,174	-12.50%
Other Services & Charges	\$189,255	\$275,227	\$380,347	\$367,201	\$492,043	\$111,696	29.37%
Intergovernmental Services	\$55,000	\$0	\$0	\$0	\$0	\$0	0.00%
Capital Outlays	\$8,900	\$0	\$0	\$0	\$0	\$0	0.00%
Interfund Payments for Service	\$713,759	\$5,199	\$10,157	\$10,157	\$12,129	\$1,972	19.42%
Total PADS Expenditures	\$3,208,045	\$2,096,367	\$2,536,798	\$2,390,797	\$2,856,866	\$320,068	12.62%
Revenue							
Budgeted Beginning Fund Balance	\$0	\$0	\$0	\$0	\$17,500	\$17,500	
Licenses & Permits	\$666,955	\$826,464	\$788,635	\$781,442	\$794,335	\$5,700	0.72%
Intergovernmental Revenue	\$30,000	\$16,100	\$0	\$0	\$0	\$0	0.00%
Charges for Goods and Services	\$354,412	\$510,990	\$515,000	\$499,321	\$498,000	-\$17,000	-3.30%
Fines	\$8,705	\$30,940	\$0	\$21,250	\$0	\$0	0.00%
Misc Revenue	\$7,074	\$9,372	\$82,500	\$7,962	\$82,500	\$0	0.00%
Other Financing Sources	\$0	\$0	\$0	\$0	\$0	\$0	
Total PADS Revenue	\$1,067,146	\$1,393,866	\$1,386,135	\$1,309,975	\$1,392,335	\$6,200	0.45%
General Fund Subsidy	\$2,140,899	\$702,501	\$1,150,663	\$1,080,822	\$1,464,531	\$313,868	27.28%
Use of Development Services Fund Balance	\$0	\$0	\$0	\$0	\$0	\$0	0.00%
Total PADS Resources	\$3,208,045	\$2,096,367	\$2,536,798	\$2,390,797	\$2,856,866	\$320,068	12.62%
Department Statistics							
% of General Fund	6.21%	7.05%	8.29%	7.81%	9.70%	1.41%	17.0%
Number of FTE's	25.90	26.90	26.90	26.90	27.50	0.60	2.2%

Planning & Development Services 2004 - 2007 Budget Comparison By Fund							
Expenditures By Fund	2006 Current					2006 Current Budget versus 2007 Budget	Percentage Change
	2004 Actual	2005 Actual	Budget	2006 Projected	2007 Budget		
General Fund	\$1,497,194	\$2,076,650	\$2,436,798	\$2,290,797	\$2,756,866	\$320,068	13.13%
Development Services Fund	\$1,691,122	NA	NA	NA	NA	NA	NA
Code Abatement Fund	\$19,729	\$19,717	\$100,000	\$100,000	\$100,000	\$0	0.00%
Total Fund Expenditures	\$3,208,045	\$2,096,367	\$2,536,798	\$2,390,797	\$2,856,866	\$320,068	12.62%
Revenue By Fund							
General Fund	\$30,566	\$1,353,554	\$1,303,635	\$1,280,763	\$1,292,335	-\$11,300	-0.87%
Development Services Fund	\$1,026,842	\$0	\$0	\$0	\$0	NA	NA
Code Abatement Fund	\$9,738	\$40,312	\$82,500	\$29,212	\$82,500	\$0	0.00%
Total Fund Revenues	\$1,067,146	\$1,393,866	\$1,386,135	\$1,309,975	\$1,374,835	-\$11,300	-0.82%
General Fund Subsidy	\$2,140,899	\$702,501	\$1,150,663	\$1,080,822	\$1,464,531	\$313,868	27.28%
Use of Code Abatement Fund Balance	\$0	\$0	\$0	\$0	\$17,500	\$17,500	
Total Fund Resources	\$3,208,045	\$2,096,367	\$2,536,798	\$2,390,797	\$2,856,866	-\$11,300	-0.45%



Planning and Development Services 2007 Budget

2007 Key Departmental Highlights

- Strike II cases in code enforcement will be transferred from P&DS to CRT enhancing the level of service for many routine and moderate cases, while creating capacity for the Code Enforcement Officer to focus on high priority, Strike III cases
- Increase requirement for neighborhood meeting noticing and occasional staff attendance to improve relations with neighborhoods and assure accuracy of information from the developer
- Current planners will perform small site drainage review to assist the backlog of work of the Development Review Engineer and increase proficiency and improve permit turnaround time
- The 2007 proposed budget includes \$130,000 in one-time expenditures. This includes \$100,000 for the development of the Natural Resources Management Strategy and \$30,000 for the development of the Town Center Plan. Both of these items are budgeted in professional services in the Current Planning program.

CODE ENFORCEMENT TEAM

PROGRAM PURPOSE:

The Code Enforcement Team enforces the City's codes and regulations to implement community values and to sustain a safe and attractive City.

STRATEGIC OBJECTIVES:

Safe and Attractive Neighborhoods and Business Districts

Measurement: EFFECTIVENESS	2004	2005	2006	2007/Target
Average number of calendar days from request initiation to voluntary compliance (Strike I)		12	5	15
Percent of abandoned vehicles tagged within 24 hours of notification	N/A	99%	98%	95%
Percentage of all cases issued a Notice and Order that are brought into compliance annually.	45%	31%	30%	38%
Percentage of all code enforcement actions resolved by voluntary compliance (Strike I)	92.7%	92%	98%	85%
Percentage of cases closed by induced compliance (Strike 2 & 3) annually	29%	30%	30%	30%
Percentage of cases open beyond 365 days (Strike 2&3)	70%	72%	70%	70%
Percentage of internal customers rating Code Enforcement overall services as good or excellent			91%	

Measurement: EFFICIENCY	2004	2005	2006	2007/Target
Code Enforcement expenditures per capita	\$2.47	\$2.70	\$2.90	\$2.90
Number of Active Cases per FTE	89	96	105	75
Number of code enforcement actions (Strike I) per FTE	219	976	494	500

Measurement: WORKLOAD	2004	2005	2006	2007/Target
Number of Code Enforcement requests for action	472	1,997	1,694	N/A
Total Number of Code Enforcement actions resolved (Strike I)	438	1,900	1,622	N/A

CODE ENFORCEMENT TEAM

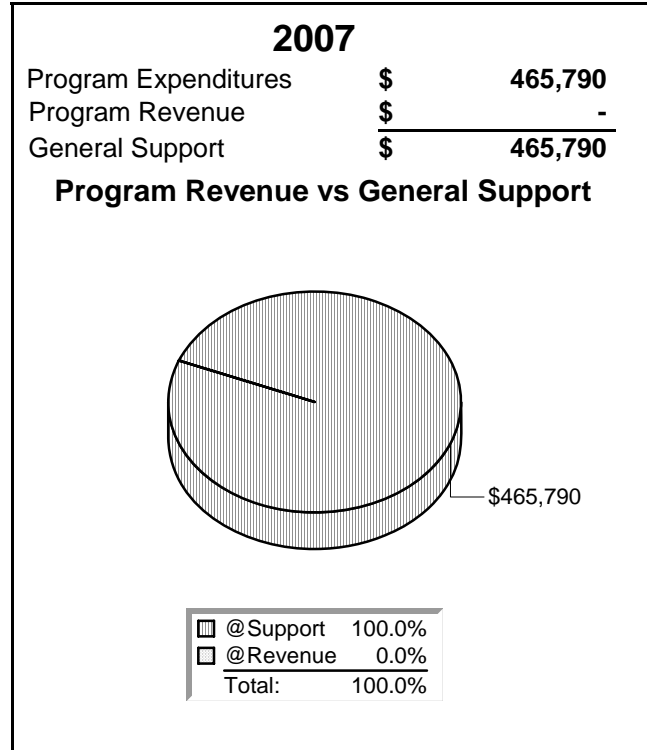
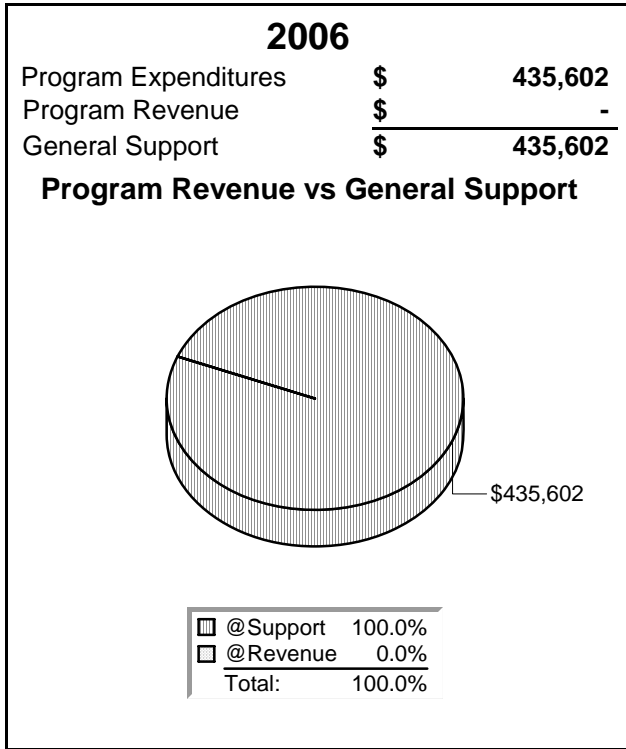

BUILDING AND INSPECTIONS TEAM

PROGRAM PURPOSE:

The Building & Inspections Team perform reviews and make decisions on more complex building permits; to provide comprehensive inspections and approval of conditions for all permitted work; and to provide enforcement and education of the adopted codes and ordinances.

STRATEGIC OBJECTIVES:

Quality Services, Facilities and Infrastructure

Measurement: EFFECTIVENESS	2004	2005	2006	2007/Target
Percent of customers who rated services as good or excellent.		93%	82%	95%
Percent of customers who said they were treated courteously by employees.		98%	98%	100%
Percent of customers who were satisfied with the clarity of inspection correction forms.		91%	95%	93%
Percent of customers who were satisfied with the timeliness of building inspections.		94%	96%	96%
Percent of customers who were satisfied with the updates they received regarding their project's status.		94%	83%	96%
Percent of customers who were satisfied with the usefulness of the pre-application process.		87%	86%	89%
Percentage of building permits issued on or before the target dates identified in SMC 20.30.040 (data includes days waiting for	92.3%	93.6%	N/A	

Measurement: EFFICIENCY	2004	2005	2006	2007/Target
Average number of Inspections Completed Per Inspector per day	8	8	8	8
Average number of plan checks completed per plans examiner annually		N/A	N/A	

Measurement: WORKLOAD	2004	2005	2006	2007/Target
Number of Addition/Remodel Commercial Permits submitted	55	79	40	64
Number of Demolition Permits submitted	36	67	60	42
Number of Fire Systems Permits submitted	105	152	110	119
Number of inspections completed annually	3,969	4,222	4,000	4,149
Number of Mechanical Permits submitted	208	286	205	215
Number of Miscellaneous Structures - Complex Permits submitted (retaining walls/rockeries, wireless facilities)	14	12	15	15
Number of New Construction Commercial Permits submitted	15	41	20	25
Number of Plumbing Permits submitted	227	216	200	210

BUILDING AND INSPECTIONS TEAM

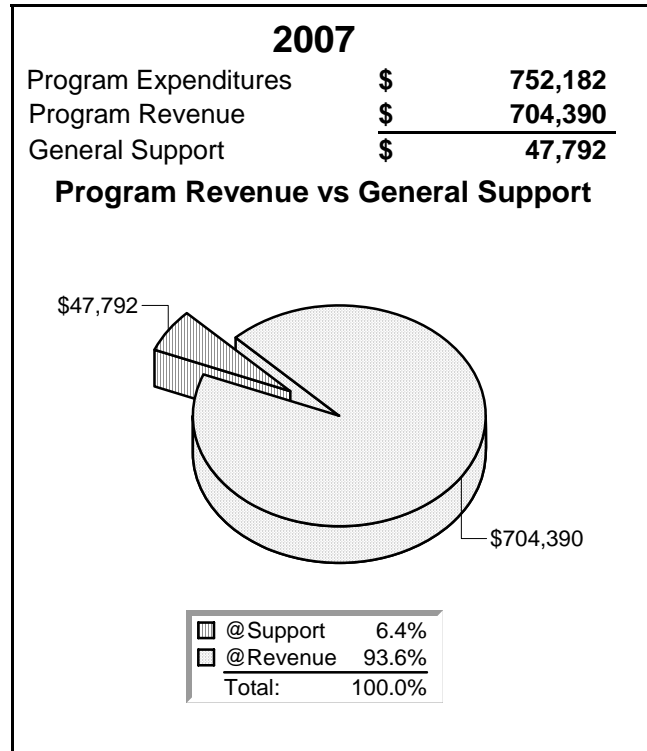
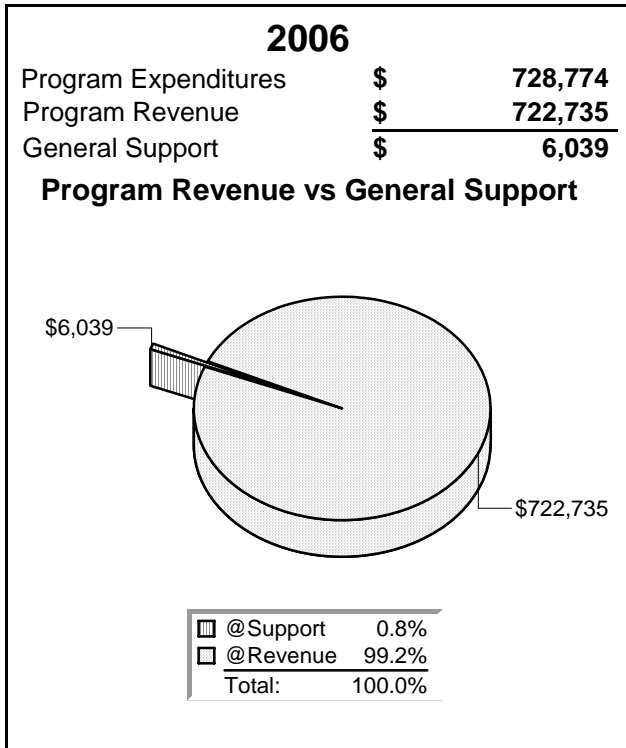

PERMIT SERVICES TEAM

PROGRAM PURPOSE:

The Permit Services Team provides accurate information and referral services; intake and issuance of all building and land use related permits; including expedited review for less complex projects.

STRATEGIC OBJECTIVES:

Governmental Excellence

Measurement: EFFECTIVENESS	2004	2005	2006	2007/Target
Percent of customers who rated services as good or excellent		93%	82%	95%
Percent of customers who said they were treated courteously by employees		98%	98%	100%
Percent of customers who were satisfied with the updates they received regarding their project's status		94%	83%	96%
Percent of customers who were satisfied with the usefulness of the pre-application process		87%	86%	89%
Percentage of permits issued on or before the target dates identified in SMC 20.30.040 (data includes days waiting for information)	94.4%	95.6%	N/A	

Measurement: EFFICIENCY	2004	2005	2006	2007/Target
Average number of permit applications submitted per Technical Assistant	517	580	525	550
Average number of permits issued per Technical Assistant	501	576	565	525

Measurement: WORKLOAD	2004	2005	2006	2007/Target
Number of Accessory Dwelling Units (ADU) or Adult Family Home Applications submitted	21	10	8	10
Number of Addition/Remodel Single-family Residential Permits submitted	189	200	224	200
Number of Home Occupation, B&B, or Boarding House Permits submitted	5	4	10	8
Number of New Construction Single-family Residential Permits submitted	71	66	80	80
Number of Sign and Miscellaneous Structure Permits submitted	37	54	30	45
Number of walk-in customers served	N/A	11,027	11,000	10,400
Number Right-of-Way Permits submitted	469	526	475	480
Total Number of Applications submitted	1,551	1,765	1,850	1,950

PERMIT SERVICES TEAM

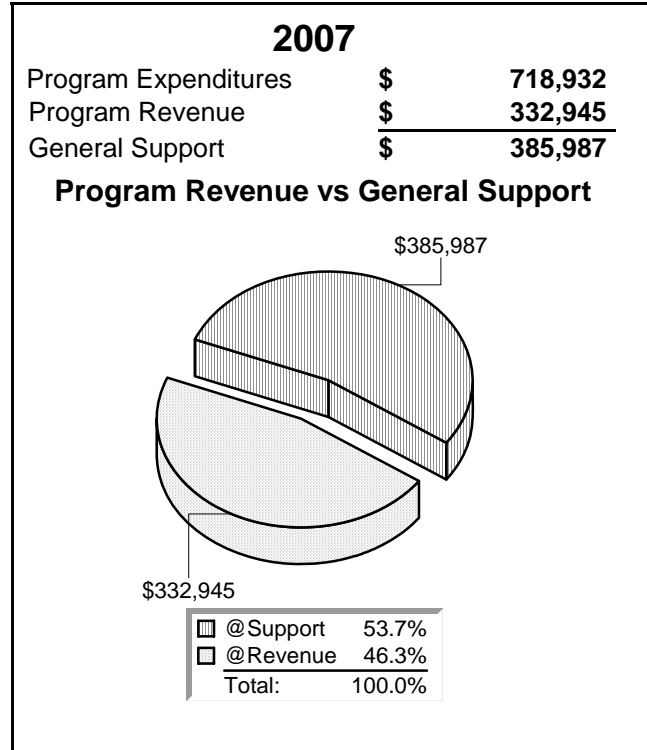
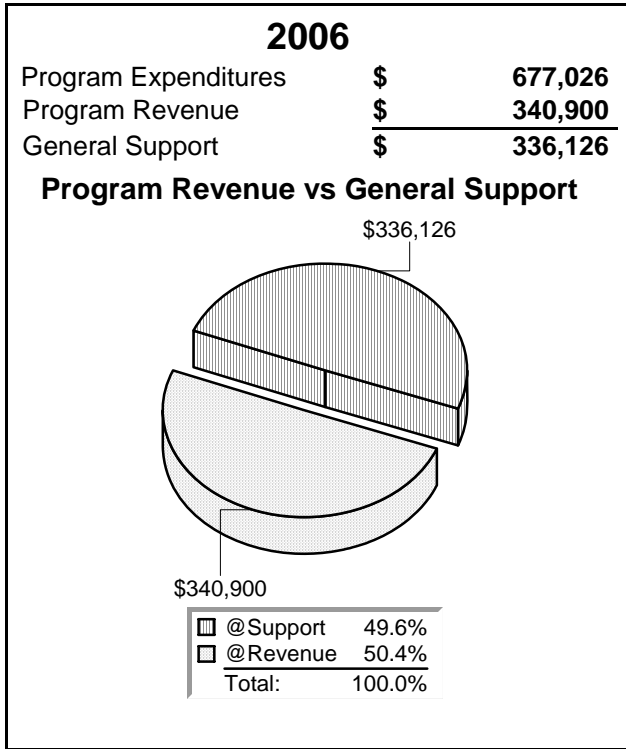

PLANNING - LONG RANGE TEAM

PROGRAM PURPOSE:

The Planning - Long Range Team provide opportunities for public input and develop staff reports and recommendations for all quasi-judicial and legislative permits and proposals

STRATEGIC OBJECTIVES:

Safe, Healthy and Sustainable Environment

Measurement: EFFECTIVENESS	2004	2005	2006	2007/Target
Percent of customers who rated services as good or excellent.		93%	82%	95%
Percent of customers who said they were treated courteously by employees.		98%	98%	100%
Percent of customers who were satisfied with the updates they received regarding their project's status.		94%	83%	96%
Percent of customers who were satisfied with the usefulness of the pre-application process.		87%	86%	89%
Percentage of permits issued on or before target dates identified in SMC 20.30.060 (data includes days waiting for Information)	88.9%	62.5%	N/A	

Measurement: WORKLOAD	2004	2005	2006	2007/Target
Number of Comprehensive Plan amendments processed annually	0	621	1	1
Number of Development Code amendments processed annually	27	24	30	20
Number of Planning Commission meetings staffed	23	26	23	23
Number of Preliminary Subdivisions submitted	2	1	0	1
Number of public disclosure requests processed	N/A	59	44	40
Number of Rezones submitted	3	1	6	1
Number of Special Use Permits (SUP) submitted	2	1	1	1

PLANNING - LONG RANGE TEAM

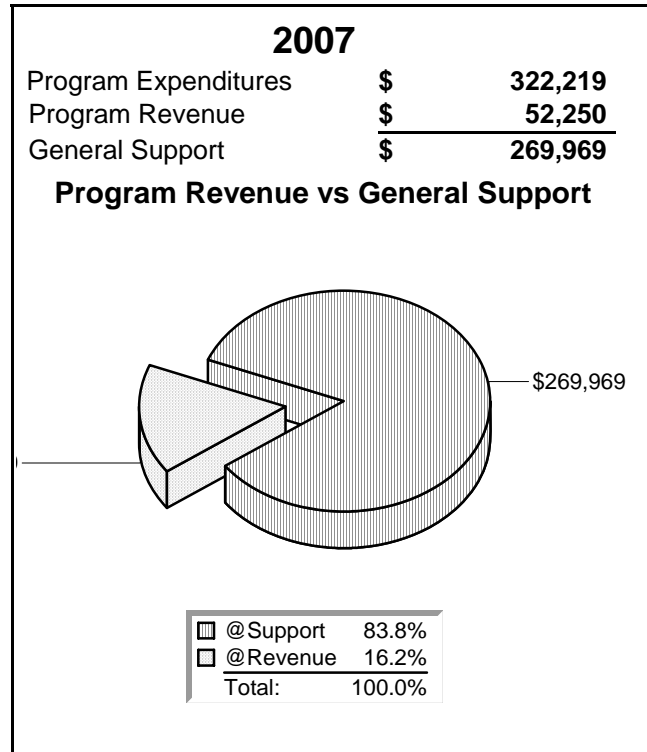
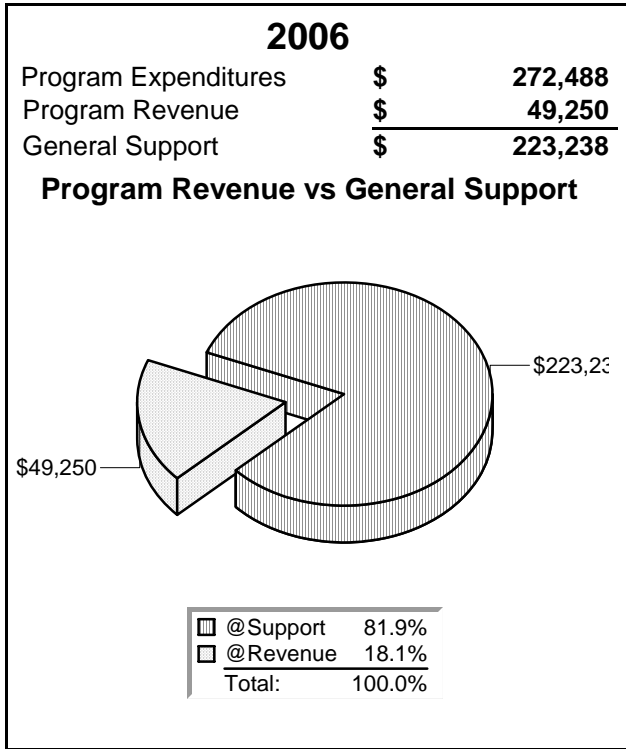

PLANNING AND DEVELOPMENT OPERATIONS SUPPORT TEAM

PROGRAM PURPOSE:

The Planning & Development Support Team provides support to enhance the Planning & Development Services Department's operations and systems through administrative and technical support; technology enhancements; managing fiscal and human resources, and implementation of a performance measurement system.

STRATEGIC OBJECTIVES:

Governmental Excellence

Measurement: EFFECTIVENESS	2004	2005	2006	2007/Target
Percent of customers who rated services as good or excellent.		93%	82%	95%
Percent of customers who said they were treated courteously by employees.		98%	98%	100%

Measurement: EFFICIENCY	2004	2005	2006	2007/Target
Operations Support Team budget as a percent of the Planning and Development Services budget.	N/A	11.5%	9.0%	10.0%

Measurement: WORKLOAD	2004	2005	2006	2007/Target
Number of archival requests retrieved annually	N/A	263	400	275

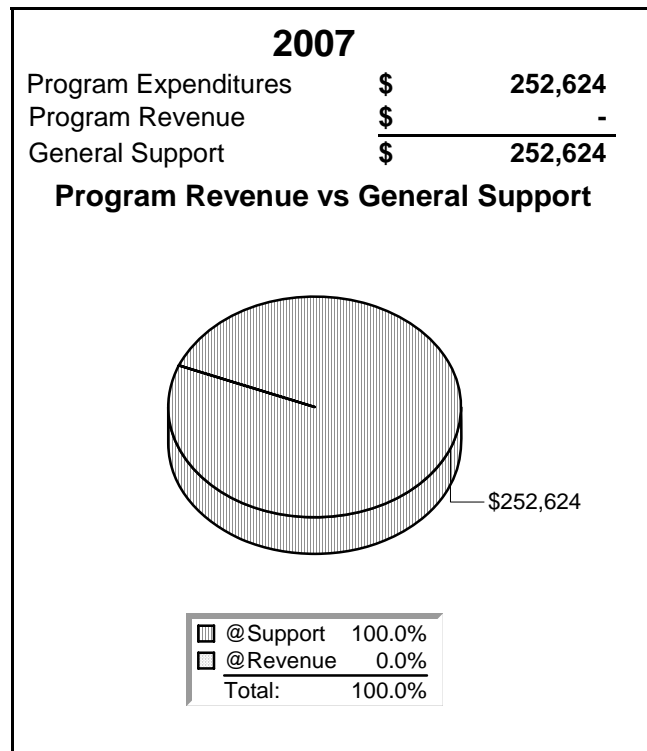
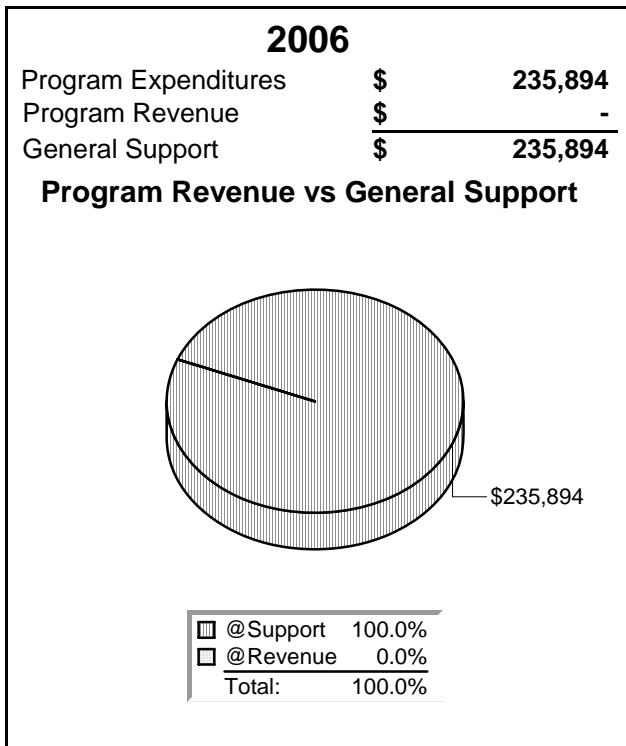

CURRENT PLANNING TEAM

PROGRAM PURPOSE:

The Current Planning Team performs reviews and make decisions on administrative land use actions.

STRATEGIC OBJECTIVES:

Quality Services, Facilities and Infrastructure

Measurement: EFFECTIVENESS	2004	2005	2006	2007/Target
Percent of customers who rated services as good or excellent.		93%	82%	95%
Percent of customers who said they were treated courteously by employees.		98%	98%	100%
Percent of customers who were satisfied with the updates they received regarding their project's status.		94%	83%	96%
Percent of customers who were satisfied with the usefulness of the pre-application process.		87%	86%	89%
Percentage of permits issued on or before target dates identified in SMC 20.30.040 and SMC 20.30.050 (data includes days waiting for	76%	56.3%	N/A	

Measurement: WORKLOAD	2004	2005	2006	2007/Target
Number of Building Permits that require SEPA submitted (new commercial exceeding 4,000 square feet)	4	14	5	7
Number of Clearing & Grading Permits submitted	20	17	10	12
Number of Conditional Use Permits submitted	3	1	2	1
Number of Development Code interpretations submitted	13	11	9	10
Number of Final Short Plats submitted	10	17	13	18
Number of Lot Line Adjustments submitted	9	12	10	12
Number of Preliminary Short Plats submitted	17	27	17	25
Number of SEPA Threshold Determinations	10	22	13	13
Number of Site Development/Construction Permits submitted	14	12	14	16
Number of Temporary Use Permits submitted	2	3	3	3
Number of Variance from Engineering Standards submitted	1	0	1	1
Number of Zoning Variances submitted	2	2	0	2

CURRENT PLANNING TEAM

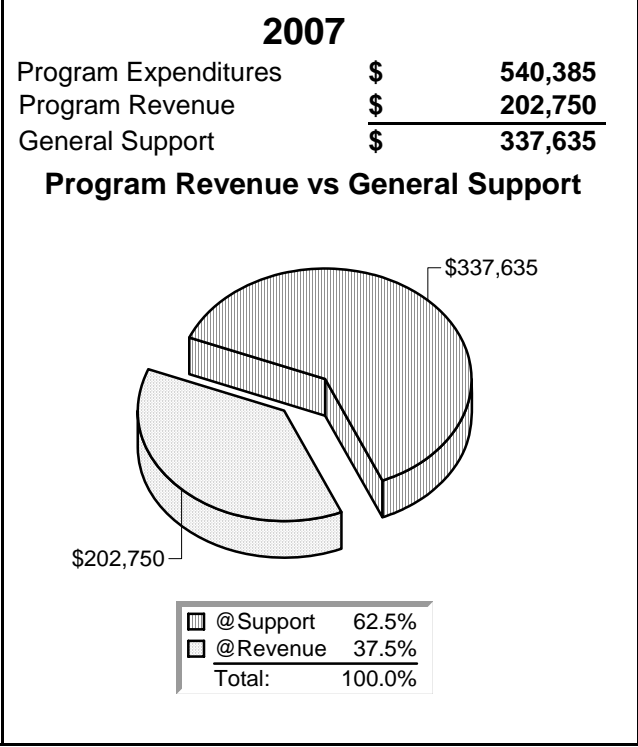
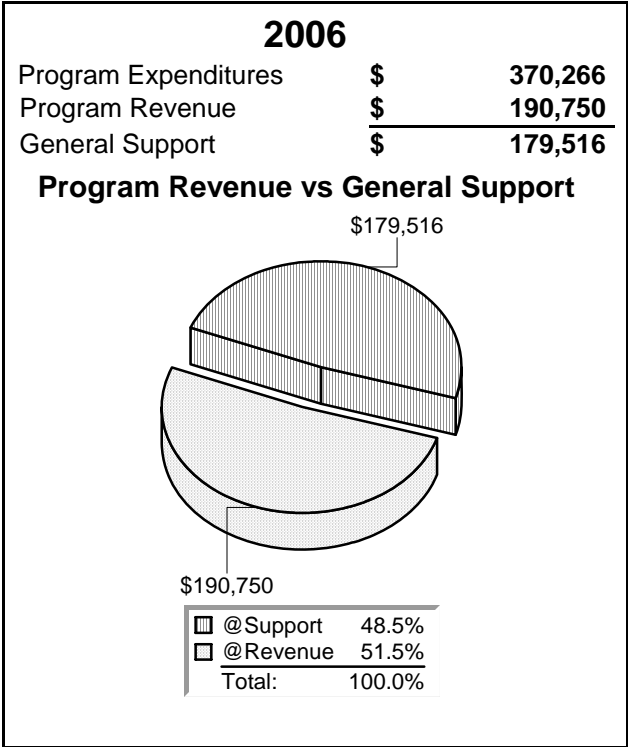



Economic Development



Economic Development Program 2007 Budget

Mission Statement

"The mission of Economic Development is to bring together the public and private resources necessary to enhance the existing business environment in Shoreline and ensure the long-term viability of the City's economic base."

Department Programs

Economic Development:
Business Attraction and
Retention

1.0 FTE

2007 Economic Development as a Share of the General Fund

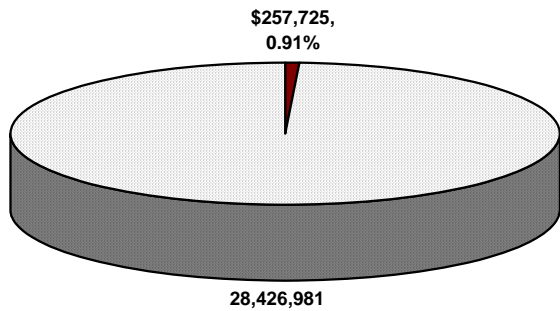

Economic Development Historical Comparison 2004 - 2007

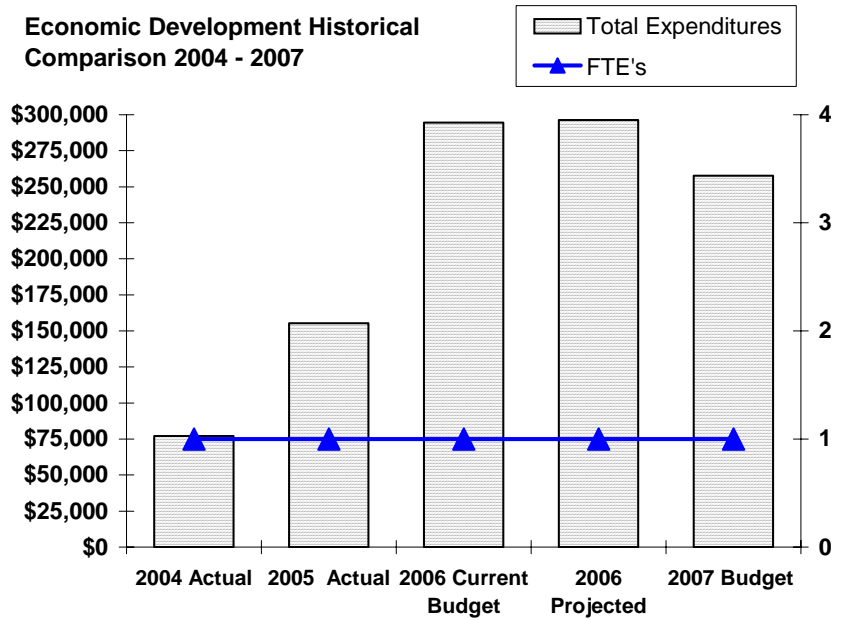



Economic Development Program 2007 Budget

2006 Key Department Accomplishments in Support of the City's Strategic Objectives:

Economic Vitality and Financial Stability

- Expanded marketing of Aurora Square and related properties to regional and national developers and retail investment brokers identified both through local contacts and at networking events of the International Council of Shopping Centers.
- Implemented a business promotion effort for North City merchants.
- Created and implemented a marketing effort in support of Aurora Avenue businesses in the area of construction from 145th to 167th Streets.
- Worked with the Economic Development Task Force to create a new economic development strategic plan that was fully endorsed by the Planning Commission and civic groups and then adopted by City Council.
- Created a small business assistance program with three components – small business training and Shoreline Loan Fund, environmental technical assistance, and property/location assistance.
- Facilitated the successful relocation of six businesses that were previously located in the North Central Interurban Trail Alignment
- Continued to work with property and business owners to promote new development in different commercial zones of the city.
- Increased the amount and quality of economic development information that is on the City's website.

Effective Citizen Communication and Engagement

- Continued a broad effort of outreach to neighborhoods, businesses, and organizations (e.g., Chamber of Commerce, Forward Shoreline, neighborhood groups) to understand business issues better.
- Advocated for the business community to ensure high levels of customer service through the development review/permit process.
- Improved administrative process for the North City property tax exemption program.
- Provided training to City staff on business customer service matters.



Economic Development Program 2007 Budget

2007 Key Department Objectives in Support of the City's Strategic Objectives:

Economic Vitality and Financial Stability

- Generate interests in redevelopment of commercial properties.
- Serve as a liaison to business organizations such as the Chamber of Commerce, Forward Shoreline, and regional groups, and be a resource to the business community.
- Implement Small Business Assistance Program.
- Develop new proposals for ways that the City can provide incentives to economic development in Shoreline.
- Manage and expand the City role in regional partnerships for economic development.
- Explore tangible linkages for economic development between the City and other local institutions such as the Shoreline Community College.
- Continued to work with property and business owners to support existing businesses and to promote new development along Aurora Avenue.
- Assist Planning and Development Services in any new planning for the Civic Center area (175th and Aurora Ave vicinity).
- Complete Ridgecrest Neighborhood Commercial Area Plan.
- Promote redevelopment of Aurora Square.

Effective citizen communication and engagement

- Continue business outreach efforts and dialogue with commercial property owners across Shoreline.
- Create brochures and enhance marketing of the Economic Development Program.
- Communicate information to the Shoreline and regional business communities about the City's economic development efforts.



Economic Development Program 2007 Budget

Economic Development 2004 - 2007 Budget Comparison By Program							
Program Budget	2004 Actual	2005 Actual	2006 Current Budget	2006 Projected	2007 Budget	2006 Current Budget versus 2007 Budget	Percentage Change
Business Attraction and Retention	\$77,066	\$155,259	\$294,521	\$296,205	\$257,725	-\$36,796	-12.49%
Total Expenditures	\$77,066	\$155,259	\$294,521	\$296,205	\$257,725	-\$36,796	-12.49%
Program Revenue							
Business Attraction and Retention	\$0	\$0	\$95,000	\$0	\$0	-\$95,000	-100.00%
Total Operations Revenue	\$0	\$0	\$95,000	\$0	\$0	-\$95,000	-100.00%
General Fund Subsidy	\$77,066	\$155,259	\$199,521	\$296,205	\$257,725	\$58,204	29.17%
Total Resources	\$77,066	\$155,259	\$294,521	\$296,205	\$257,725	-\$36,796	-12.49%

Economic Development 2004 - 2007 Budget Comparison By Object							
Object Category	2004 Actual	2005 Actual	2006 Current Budget	2006 Projected	2007 Budget	2006 Current Budget versus 2007 Budget	Percentage Change
Salaries	\$46,111	\$60,483	\$78,603	\$78,664	\$88,262	\$9,659	12.29%
Benefits	\$7,966	\$14,259	\$17,910	\$17,915	\$21,713	\$3,803	21.23%
Supplies	\$47	\$4,326	\$750	\$650	\$750	\$0	0.00%
Other Services & Charges	\$22,942	\$76,191	\$197,258	\$198,849	\$147,000	-\$50,258	-25.48%
Intergovernmental Services	\$0	\$0	\$0	\$127	\$0	\$0	
Capital Outlays	\$0	\$0	\$0	\$0	\$0	\$0	0.00%
Total Expenditures	\$77,066	\$155,259	\$294,521	\$296,205	\$257,725	-\$36,796	-12.49%
Revenue Category							
Licenses & Permits	\$0	\$0	\$95,000	\$0	\$0	-\$95,000	0.00%
Total Operations Revenue	\$0	\$0	\$95,000	\$0	\$0	-\$95,000	-100.00%
General Fund Subsidy	\$77,066	\$155,259	\$199,521	\$296,205	\$257,725	\$58,204	29.17%
Total Resources	\$77,066	\$155,259	\$294,521	\$296,205	\$257,725	-\$36,796	-12.49%
Department Statistics							
FTE's	1	1	1	1	1	0	0.00%
% of General Fund	0.32%	0.53%	1.00%	1.01%	0.91%	-0.10%	-9.50%

* When comparing the 2006 projected column to the 2006 current budget column it appears that the department will exceed their budget. This will not occur as the 2006 projected expenditures for "other services & charges" is overstated.



Economic Development Program 2007 Budget

2007 Budget Highlights

Summary of Professional Service Contracts for 2007:

Professional Services = \$135,000

- Small Business Services \$81,000
 - CCD contract \$50,000
 - ECOSS contract \$20,000

 - Relocation and Lease Assistance \$6,000
 - Shoreline Community College Partnership/Training Space \$5,000
- Real Estate Advisory Services \$17,000
 - Clearpath (Wedges) \$6,000
 - Clearpath/Colliers (Aurora Square) \$11,000
- Media, Marketing and Arts Council Partnerships \$17,000
 - Media \$4,000
 - Brochures (\$0 – use 2006 budget) \$0
 - Arts Council \$1,000
 - Buxton Portal \$12,000
- Sustainable Neighborhoods Project (Ridgecrest Planning) \$20,000
 - UW Charrette \$20,000

The 2006 budget included \$20,000 in one-time professional services contracts

The 2007 budget does not include funding for the Forward Shoreline contract

Business license revenue is categorized as a general administration revenue source and not part of the economic development program in 2007.

ECONOMIC DEVELOPMENT: BUSINESS ATTRACTION AND RETENTION

PROGRAM PURPOSE:

To bring together public and private resources necessary to enhance the existing business environment in Shoreline and ensure the long-term viability of the City's economic base.

STRATEGIC OBJECTIVES:

Economic Vitality and Financial Stability

Measurement: EFFECTIVENESS	2004	2005	2006	2007/Target
Percentage of City assessed valuation that is classified commercial	9.2%	9.1%	9.09%	
Sales Tax Per Capita	\$109.28	\$108.07	\$110.20	\$118.30

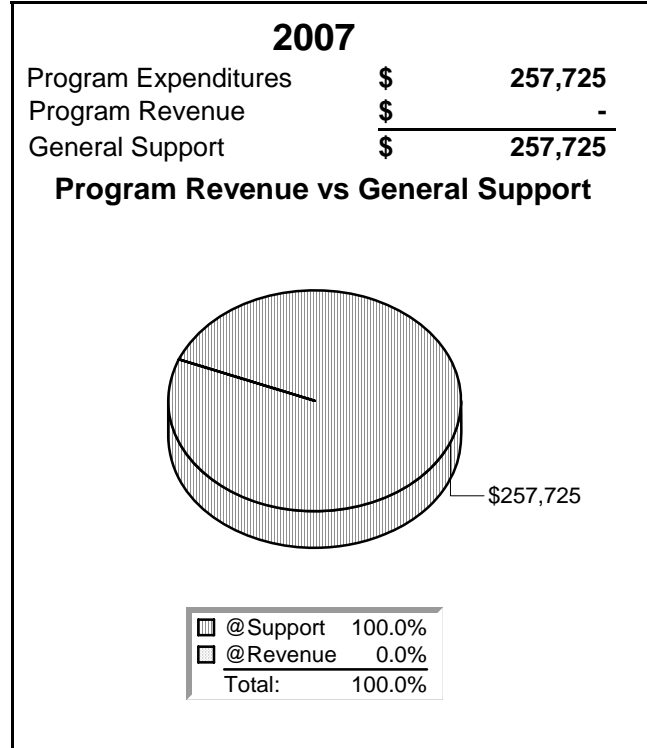
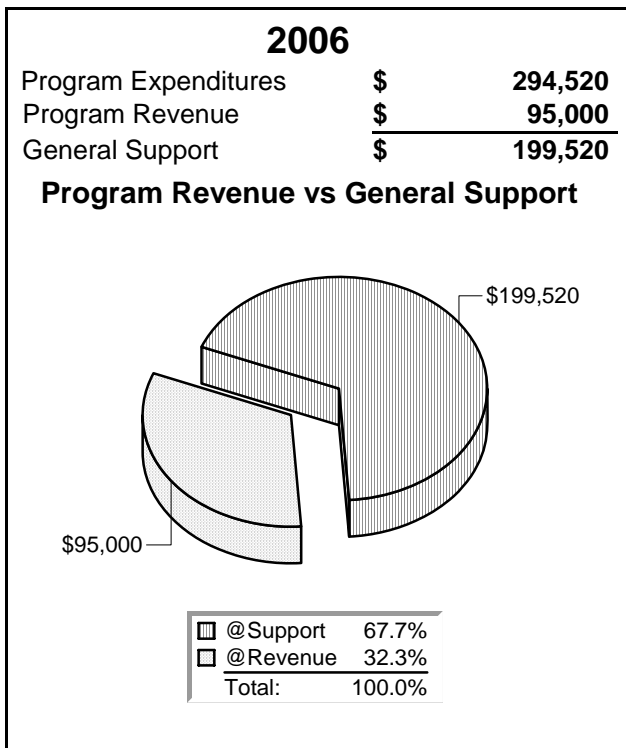



Public Works



Public Works 2007 Budget

Mission Statement

*“Public Works: What are we doing to make a difference? Public Works employees are guided by the principles of integrity, respect and partnerships combined with innovation, hard work and customer responsiveness. We, as a team are dedicated to maintaining and improving our City’s infrastructure through positive and proactive leadership, education, planning and the delivery of quality projects on time, on target and on budget while being strong stewards of the environment, public safety, and fiscal resources. **Public Works Employees strive to be known for getting it done ...and done well.”***

Department Programs

Administration

2.15 FTE

Public Facilities and Vehicle Maintenance & Operations

2.45 FTE

Environmental Services

0.35 FTE

Street Operations & Pavement Resurfacing Program

9.25 FTE

Right of Way Permit & Inspection Program

1.3 FTE

Surface Water Management

6.8 FTE

Traffic Services & NTSP

2.26 FTE

*An Additional 12.44
Public Works’ FTEs are
budgeted in the Capital
Funds



Public Works 2007 Budget

2007 General Fund Portion of Public Works as a Share of the General Fund

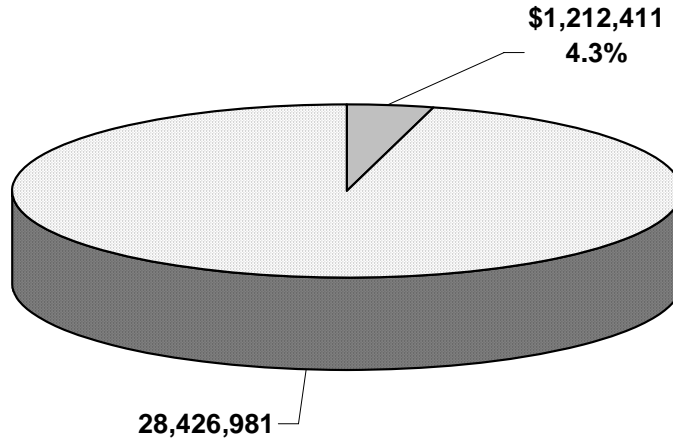

Public Works All Funds Historical Comparison

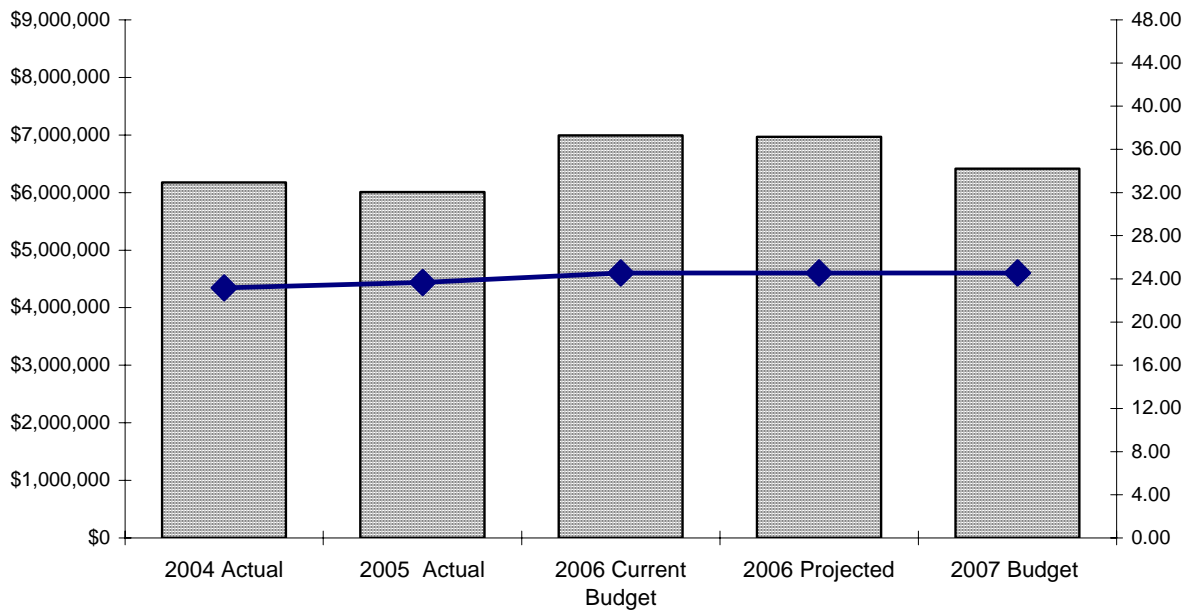
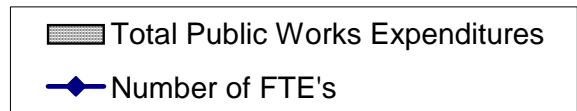



Public Works 2007 Budget

2006 Key Department Accomplishments in Support of the City's Strategic Objectives:

Safe and Attractive Neighborhoods and Business Districts

- Installed a new fire signal at the N 155th St Fire Station
- Installed a UPS battery backup at Aurora Ave N/N 185th St
- Completed the purchase of (4) portable radar trailers
- Completed roadway design for Ashworth Ave N/N 152nd St
- Installed countdown ped heads at Aurora Ave N/N 180th St
- Completed the update of the Signal Condition Report
- Rebuilt traffic signals at 19th Ave NE/NE 205th St; Fremont Ave N/N 185th St; and 5th Ave NE/NE 155th
- Applied for and was awarded a grant to install school zone flashers
- Completed arterial speed limit study
- Completed a signal warrant study at 15th Ave NE/NE 170th St
- Completed traffic safety demonstration projects at St Lukes Place and 10th Ave NE/NE 170th St
- Completed traffic action plans for Ridgecrest, Briercrest, North City, Echo Lake, Ballinger and Westminster
- Completed the installation of 40 traffic control devices

Safe, Healthy, and Sustainable Environment

- Implemented Hidden Lake forebay dredging project
- Completed the monitoring of Echo Lake for water quality
- Completed weekly monitoring of swimming beaches at Echo Lake and Hidden Lake for bacteria
- Served 800-1000 residents at annual Natural Yard Care Event; 2200 customers at Recycling Events; and Chipped 1715 trees at Christmas Tree Recycling Event
- Installed 1000-4" metal decals next to catch basins for surface water education
- Completed the 2006 Overlay and Slurry Seal of City streets
- Inspected 100 regional and 25% of the commercial drainage facilities for compliance with maintenance standards
- Assisted King County with recycling center design and community response to closure of First N.E. Transfer Station for LEED-certificated renovation
- Assisted in development of Regional Hazardous Waste Recycling Plan for businesses in Shoreline and King County, in conjunction with Local Hazardous Waste Management Program's strategic planning process

Quality Services, Facilities and Infrastructure

- Created a video log of the City's streets



Public Works 2007 Budget

- Completed city facility and park capital improvement projects; transportation and drainage basin improvements as scheduled in the CIP

Economic Vitality and Financial Stability

- Completed construction of the Aurora Corridor Project (N. 145th Street – N. 165th Street)
- Complete construction of the 15th Avenue NE/North City Business District Improvements
- Awarded 3 grants totaling \$161,357 to support the City's recycling program for 2 years

2007 Key Department Objectives in Support of the City's Strategic Objectives:

Safe and Attractive Neighborhoods and Business Districts

- Install two battery backup units at critical signalized locations
- Complete six (6) Neighborhood Traffic Action Plans
- Complete 2007-08 priority sidewalk projects
- Implement an "adopt-a-road" program
- Create "Appendix A" for the development guide – which identifies the existing and proposed roadway and ROW widths for all streets

Safe, Healthy, and Sustainable Environment

- Work with the Aurora Corridor Team to incorporate storm water –related sustainability principles into the Phase II Design
- Create demonstration SWM standards for Aurora Phase II
- Review and amend the 2005 King County Surface Water Design Manual (includes Low Impact Development) to fit the needs of Shoreline
- Coordinate Natural Yard Care, Christmas Tree Chipping, and Clean Sweep Recycling Events
- Continue inspection of Regional, Residential, and Commercial Storm Water facilities and water quality monitoring of Hidden Lake, Echo Lake and other water resources.
- Ongoing coordination with the King County Hidden Lake Pump Station and Boeing Creek Trunk Sewer Project
- Develop Neighborhood Environmental Stewardship [Teams](#) (NEST)
- Actively participate in the Thornton Creek Watershed Oversight Committee, Lake Ballinger Watershed Meeting, WRIA 8, Regional Road Maintenance, Local Hazardous Waste Management Program regional meetings, and municipal solid waste planning forums



Public Works 2007 Budget

- Update Storm Water Management Standards including low impact.
- Identify site selection criteria and identify locations for Green Street Projects
- Assist with incorporating sustainability principles into City Hall project
- Align programmatic activities and applicable City codes to comply with NPDES Phase II permit that is scheduled to become effective January 2007
- Implement Business Waste Reduction & Recycling Outreach Program
- Implement a “Green Street” demonstration project

Quality Services, Facilities and Infrastructure

- Complete the 2007 Overlay and Slurry Seal of City’s Streets
- Complete Interurban Trail and bridges
- Work with transit providers to expand transit in Shoreline
- Implement Transportation Master Plan
- Complete 2007-08 pavement projects
- Complete Aurora Phase I
- Complete the environmental analysis, preliminary design and public process for Aurora Phase II

Economic Vitality and Financial Stability

- Worked with Economic Development Manager to develop a Marketing Plan
- Negotiate acquisition of SPU water system
- Initiate Aurora construction mitigation promotion

Effective Citizen Communication and Engagement

- Update website for traffic count summaries and update traffic flow map



Public Works 2007 Budget

Public Works Breakdown by Fund

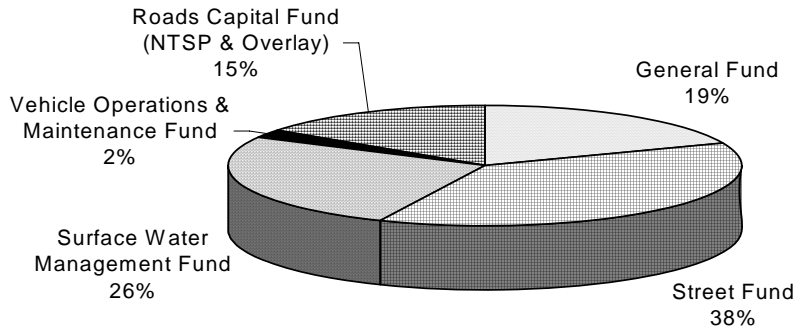

Public Works Services 2004 - 2007 Budget Comparison By Program							
Program Budget	2004 Actual	2005 Actual	2006 Current Budget	2006 Projected	2007 Budget	2006 Current Budget versus 2007 Budget	Percentage Change
Environmental Services	\$120,773	\$128,181	\$192,138	\$273,279	\$152,028	-\$40,110	-20.88%
Right-of-way Permit & Inspection	\$86,561	\$101,835	\$103,444	\$90,133	\$113,527	\$10,083	9.75%
Street Operation & Pavement Resurfacing	\$2,865,729	\$2,643,335	\$2,981,883	\$2,949,505	\$2,865,851	-\$116,032	-3.89%
Surface Water Management	\$1,125,651	\$1,428,275	\$1,714,049	\$1,653,214	\$1,672,866	-\$41,183	-2.40%
Traffic Services & Neighborhood Traffic Safety*	\$346,329	\$344,169	\$574,977	\$574,915	\$408,709	-\$166,268	-28.92%
Public Facility & Vehicle Maintenance & Operations	\$1,396,629	\$1,101,923	\$1,151,833	\$1,151,833	\$907,390	-\$244,443	-21.22%
Public Works Administration	\$233,088	\$260,781	\$273,600	\$273,600	\$292,981	\$19,381	7.08%
Non-Program Specific Transfers to Other Funds	\$0	\$0	\$0	\$0	\$0	\$0	#DIV/0!
Total Program Budget	\$6,174,760	\$6,008,499	\$6,991,924	\$6,966,479	\$6,413,352	-\$578,572	-8.27%
Program Revenue							
Environmental Services	\$90,408	\$102,501	\$155,710	\$236,859	\$122,616	-\$33,094	0.00%
Right-of-way Permit & Inspection	\$103,132	\$213,514	\$111,469	\$111,469	\$120,000	\$8,531	7.65%
Street Operation & Pavement Resurfacing	\$764,251	\$759,642	\$1,265,725	\$1,380,464	\$1,373,278	\$107,553	8.50%
Surface Water Management	\$2,507,159	\$2,602,140	\$2,754,067	\$2,903,738	\$2,100,534	-\$653,533	-23.73%
Traffic Services & Neighborhood Traffic Safety	\$613	\$578	\$0	\$1,455	\$0	\$0	0.00%
Public Facility & Vehicle Maintenance & Operations	\$58,705	\$73,950	\$88,717	\$100,782	\$139,988	\$51,271	57.79%
Public Works Administration	\$10	\$0	\$0	\$0	\$0	\$0	0.00%
Total Program Revenue	\$3,524,278	\$3,752,325	\$4,375,688	\$4,734,767	\$3,856,416	-\$519,272	-11.87%
General Fund Subsidy	\$2,650,482	\$2,114,243	\$2,526,462	\$2,231,712	\$2,436,936	-\$89,526	-3.54%
Use of Streets Fund Balance	\$0	\$0	\$89,774	\$0	\$120,000	\$30,226	\$0
Use of Surface Water Management Fund Balance	\$0	\$133,089	\$0	\$0	\$0	\$0	\$0
Use of Vehicle Oper. & Maint. Fund Balance	\$0	\$8,842	\$0	\$0	\$0	\$0	\$0
Total Resources	\$6,174,760	\$6,008,499	\$6,991,924	\$6,966,479	\$6,413,352	-\$578,572	-8.27%

* The 2007 Neighborhood Traffic Safety Program has components of the program budgeted in the Police Department budget (\$50,005)



Public Works 2007 Budget

Public Works 2004 - 2007 Operating Budget Comparison By Object							
Object Category Name	2004 Actual	2005 Actual	2006 Current		2007 Budget	2006 Current Budget versus 2007 Budget	Percentage Change
			Budget	2006 Projected			
Salary	\$1,229,540	\$1,420,035	\$1,536,676	\$1,481,467	\$1,629,296	\$92,620	6.03%
Benefits	\$330,386	\$367,018	\$420,620	\$402,799	\$497,437	\$76,817	18.26%
Supplies	\$352,771	\$379,505	\$291,504	\$373,663	\$353,158	\$61,654	21.15%
Services	\$2,013,307	\$1,522,633	\$1,818,146	\$1,789,501	\$1,403,795	-\$414,351	-22.79%
Intergovernmental Services	\$551,827	\$581,126	\$677,834	\$693,043	\$445,814	-\$232,020	-34.23%
Capital	\$625,918	\$630,685	\$1,032,401	\$1,012,023	\$1,037,868	\$5,467	0.53%
Debt Service	\$227,731	\$319,943	\$319,944	\$319,944	\$326,475	\$6,531	2.04%
Debt Service Interest	\$10,177	\$23,668	\$25,506	\$25,595	\$24,425	-\$1,081	-4.24%
Interfund Payments for Service	\$833,103	\$763,886	\$869,293	\$868,444	\$695,084	-\$174,209	-20.04%
Total Public Works Expenditures	\$6,174,760	\$6,008,499	\$6,991,924	\$6,966,479	\$6,413,352	-\$578,572	-8.27%
Revenue Source							
Licenses and Permits	\$103,745	\$214,092	\$111,469	\$111,574	\$120,000	\$8,531	7.65%
Intergovernmental Revenues	\$779,488	\$789,144	\$1,344,755	\$1,474,539	\$1,404,906	\$60,151	4.47%
Charges for Goods and Services	\$2,446,437	\$2,465,246	\$2,691,567	\$2,691,582	\$1,992,914	-\$698,653	-25.96%
Fines & Forfeits	\$67	\$0	\$0	\$11	\$0		
Miscellaneous Revenues	\$194,541	\$283,843	\$227,897	\$457,061	\$338,596	\$110,699	48.57%
Total Revenue	\$3,524,278	\$3,752,325	\$4,375,688	\$4,734,767	\$3,856,416	-\$519,272	-11.87%
General Fund Subsidy	\$2,650,482	\$2,114,243	\$2,526,462	\$2,231,712	\$2,436,936	-\$89,526	-3.54%
Use of Streets Fund Balance	\$0	\$0	\$89,774	\$0	\$120,000	\$30,226	33.67%
Use of Surface Water Management Fund Balance	\$0	\$133,089	\$0	\$0	\$0	\$0	
Use of Vehicle Oper. & Maint. Fund Balance	\$0	\$8,842	\$0	\$0	\$0	\$0	
Total Resources	\$6,174,760	\$6,008,499	\$6,991,924	\$6,966,479	\$6,413,352	-\$578,572	-8.27%
Department Statistics							
General Fund Portion of Public Works as a % of Total General	10.99%	7.18%	8.59%	7.61%	4.27%	-4.33%	-50.4%
Number of FTE's	23.16	23.66	24.56	24.56	24.56	0.00	0.0%

The Public Works Department is also responsible for four other City funds: the Street Fund, Surface Water Utility, Vehicle Operations & Maintenance and Roads Capital. The fund breakdown is displayed below.

Public Works Expenditures by Fund	2004 Actual	2005 Actual	2006 Current		2007 Budget	2006 Current Budget versus 2007 Budget	Percentage Change
			Budget	2006 Projected			
General Fund	\$1,683,021	\$1,411,904	\$1,528,854	\$1,609,995	\$1,212,411	-\$316,443	-20.7%
Street Fund	\$2,392,231	\$2,224,959	\$2,559,651	\$2,513,556	\$2,422,087	-\$137,564	-5.4%
Surface Water Management Fund	\$1,107,239	\$1,428,275	\$1,714,049	\$1,653,214	\$1,672,866	-\$41,183	-2.4%
Vehicle Operations & Maintenance Fund	\$67,469	\$78,981	\$88,717	\$88,717	\$139,988	\$51,271	57.8%
Roads Capital Fund (NTSP & Overlay)	\$924,800	\$864,380	\$1,100,653	\$1,100,997	\$966,000	-\$134,653	-12.2%
Total Public Works Expenditures	\$6,174,760	\$6,008,499	\$6,991,924	\$6,966,479	\$6,413,352	-\$578,572	-8.3%



Public Works 2007 Budget

2007 Budget Highlights

- The 2006 Environmental Services program budget included \$36,106 of grant funds from the Washington State Department of Ecology Coordinated Prevention Grant. This grant is received every other year, and therefore there are no CPG related grant revenues or expenditures in the 2007 budget.
- The lease expense for City Hall and the City Annex are accounted for in the Facilities program within Public Works. As a result of the acquisition of the City Annex building and property the City's lease payments have been reduced by \$288,000 in 2007 and is reflected in a lower budget for the Facilities program and a reduction services and charges in the Public Works budget.
- The 2007 budget includes the recommended acquisition of a street sweeper. The acquisition cost is estimated at \$150,000 and is being funded by the City Street Fund (\$90,000) and the Surface Water Utility Fund (\$90,000). The benefits for acquiring a street sweeper and performing street sweeping activities in-house include the following:
 - Current staffing levels are adequate to provide this service
 - The cost to provide the street sweeping services in-house is expected to be lower than the cost that the City is currently incurring to contract for this service with King County and a private contracting company. The following comparison of in-house services versus contract services shows that annually the City is expected to save \$58,286 and that after 8 years and accounting for the \$150,000 investment in the street sweeper the net savings to the City are projected at \$316,288. Savings will be recognized in both the City Street Fund and the Surface Water Utility Fund.

	Current Street Sweeping Budget	Proposed Street Sweeping Budget	Difference
<u>Annual Costs</u>			
Contract Service	127,661	25,000	(102,661)
Dumping Fees		10,500	10,500
Maintenance & Fuel Costs		12,000	12,000
Funding for Replacement of Sweeper - assume 8 year life		21,875	21,875
Total Annual Costs	127,661	69,375	(58,286)
Annual cost for 8 years	1,021,288	555,000	(466,288)
Plus: Purchase Price of the Street Sweeper		150,000	150,000
Total cost for 8 years	1,021,288	705,000	(316,288)



Public Works 2007 Budget

- The 2007 Street Services budget includes \$49,425 for the maintenance of improvements made as part of the 145th to 165th Aurora project and the pedestrian bridges that are part of the Interurban trail. These maintenance costs include: irrigation system maintenance, bridge maintenance, traffic control devices, bridge window cleaning, street lighting, median maintenance, and trash pick-up. The surface water operation budget includes \$25,575 for filtration associated costs related to the improvements that have been completed.
- The 2006 Traffic Services program budget included \$83,774 in 2005 carry-over expenditures. The carry-over was to complete projects started in 2005, but not completed until 2006. These are considered one-time dollars and are not included in the 2007 budget.
- The 2006 surface water operating budget included \$130,000 in 2005 carry-over expenditures. Carry-over items are considered one-time and are not included in the 2007 budget.
- The 2006 Neighborhood Traffic Safety Program within the Roads Capital Fund included \$89,000 in 2005 carry-over expenditures. Carry-over items are considered one-time and are not included in the 2007 budget. The 2007 budget reflects the annual level of funding approved as part of the 2007-2012 Capital Improvement Program.
- The 2006 Road Surface Maintenance Program within the Roads Capital Fund included \$95,000 in 2005 carry-over expenditures. Carry-over items are considered one-time and are not included in the 2007 budget. The 2007 budget reflects the annual level of funding approved as part of the 2007-2012 Capital Improvement Program.

ENVIRONMENTAL SERVICES

PROGRAM PURPOSE:

Provide waste reduction and recycling education programs to the community. Coordinate recycling events, provide resource materials (compost bins, etc.), and manage the City's single solid waste service contract.

STRATEGIC OBJECTIVES:

Safe, Healthy and Sustainable Environment

Measurement: EFFECTIVENESS	2004	2005	2006	2007/Target
Percentage of households participating in City recycling events	12.9%	18.0%	22.7%	23.0%

Measurement: OTHER	2004	2005	2006	2007/Target
Number of households participating in annual recycling opportunities	2,681	3,700	4,928	5,000

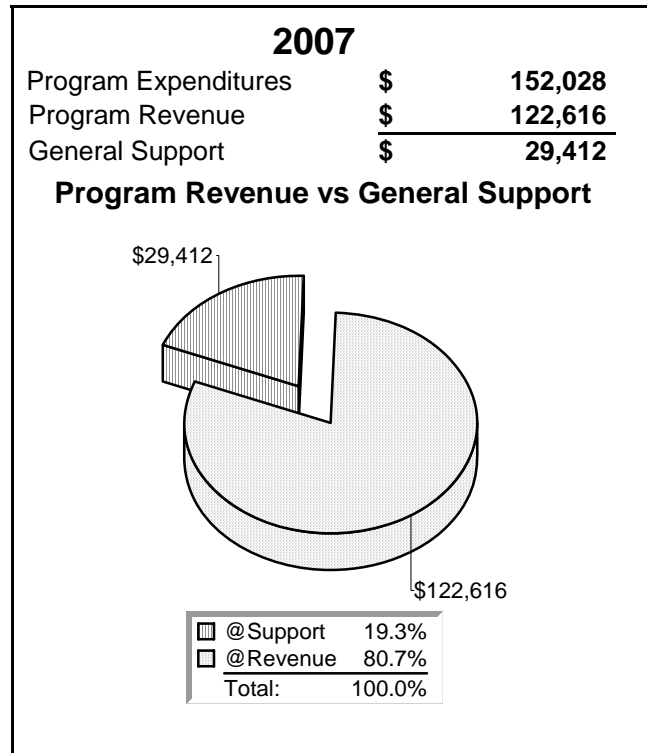
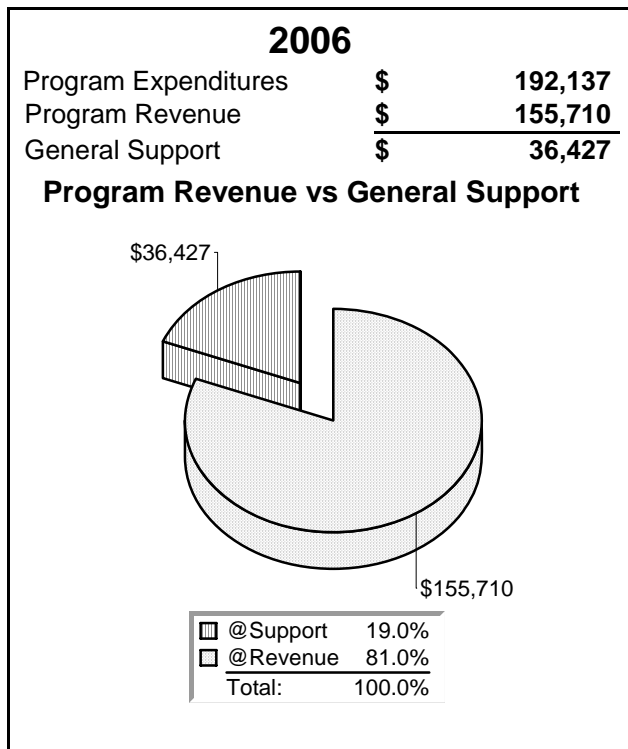

RIGHT-OF-WAY PERMIT AND INSPECTION PROGRAM

PROGRAM PURPOSE:

Review planned work and inspect construction/work taking place in the public right-of-way, manage City franchises in the right-of-way, and provide plan review services on planning and development project applications submitted to the City's Planning and Development Services Department.

STRATEGIC OBJECTIVES:

Governmental Excellence

Measurement: EFFICIENCY	2004	2005	2006	2007/Target
Number of ROW inspections completed per FTE	608	781	800	825

Measurement: WORKLOAD	2004	2005	2006	2007/Target
Number of inspections performed	790	1,003	1,050	1,075
Number of right-of-way permits issued	462	511	520	525

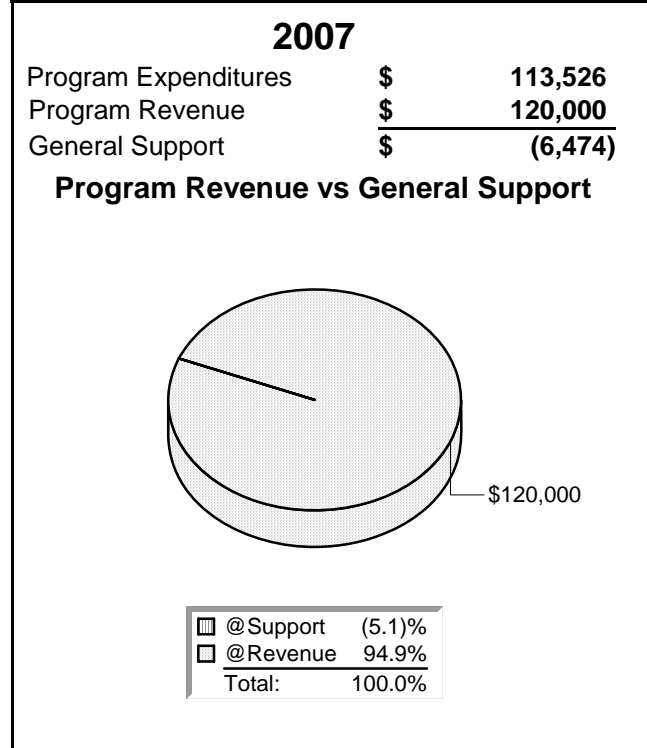
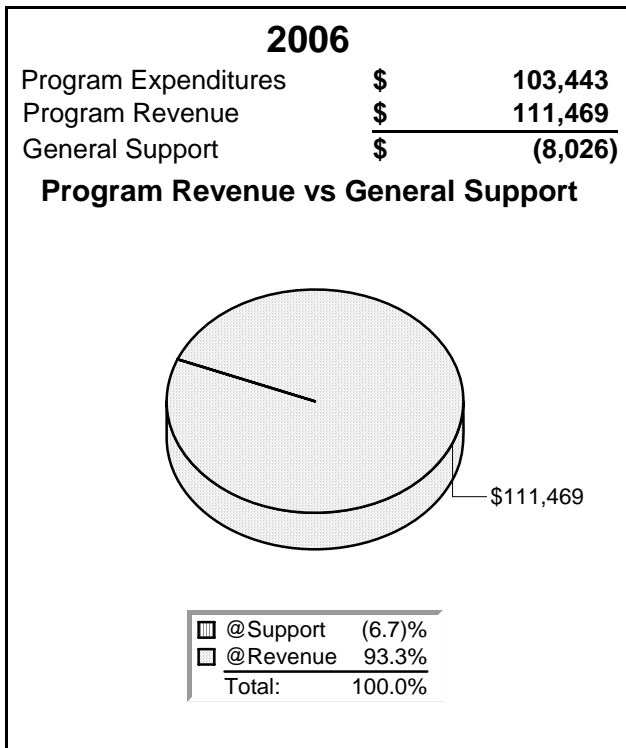

STREET OPERATION & PAVEMENT RESURFACING PROGRAMS

PROGRAM PURPOSE:

Vegetation & Tree Maintenance in Right-of-Way: Maintains public rights-of-way by tree trimming, controlling vegetation, grading and other methods.

Street Maintenance & Operations: Manages the city's road overlay, curb ramp, and sidewalk programs. Provides maintenance and upkeep of city streets and roads. This service includes pothole patching, crack sealing, street sweeping, and snow and ice removal. Provides general maintenance support for the City including signing, striping, fence/barricade repair, parking lot maintenance, and other odd jobs.

Pavement Resurfacing: Provide long-term maintenance and upkeep of City streets and roads. This service includes asphalt overlay, slurry sealing, crack sealing, pot hole patching, and emulsion application

Street Lighting: Provides funding for street lights on arterial streets and traffic signalization. Maintains inventory data on all streetlights, through a GPS network mapping system.

STRATEGIC OBJECTIVES:

Quality Services, Facilities and Infrastructure

Measurement: EFFECTIVENESS	2004	2005	2006	2007/Target
Average pavement rating for arterials/collectors.	71.9	72	72	72
Average pavement rating for residential streets.	75	80.8	80.8	80.8
Percentage of citizens surveyed that are satisfied with the adequacy of city street lighting on arterial streets	60%	60%	60%	
Weighted average pavement rating for all City streets.	76.0	81.3	>76.0	>76.0

Measurement: EFFICIENCY	2004	2005	2006	2007/Target
Annual operating and maintenance costs per City traffic signal	\$3,364	\$5,780	\$5,800	\$5,850
Annual street operation expenditures per paved lane mile in the City	\$3,651	\$3,551.45	\$3,900	\$3,900
Cost per lane mile for asphalt overlay	\$54,335	\$45,974	\$46,000	\$50,000
Cost per lane mile for slurry seal	\$9,629	\$8,542	\$9,925.	\$10,000.
Cost per lane mile of street sweeping	\$22.67	\$22.20	\$25.00	\$30.00

Measurement: WORKLOAD	2004	2005	2006	2007/Target
Collector Arterials total lane miles	32.81	32.81	32.81	32.81
Contract hours spent sanding & plowing roads	101	65.6	65	65
In-house hours spent sanding & plowing roads	99	286.5	200	200
Number of lane miles rehabilitated with slurry seal	14.8	13.6	11.6	11.6

STREET OPERATION & PAVEMENT RESURFACING PROGRAMS

	2004	2005	2006	2007/Target
Number of lane miles resurfaced with asphalt overlay	9.1	13.4	8.28	8.28
Number of lane miles swept	2,405	2,007	1754	1800
Number of new traffic signs installed		162	375	150
Number of potholes repaired		59	50	50
Number of traffic signs maintained	273	275	235	260
Principle Arterials Total Lane Miles	22.22	22.22	22.22	22.22
Residential Streets total lane miles			290.81	290.81

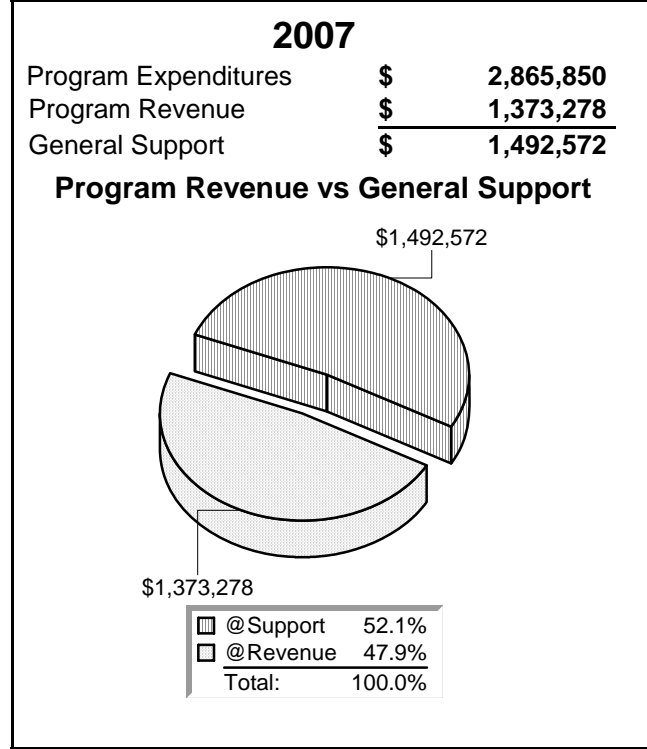
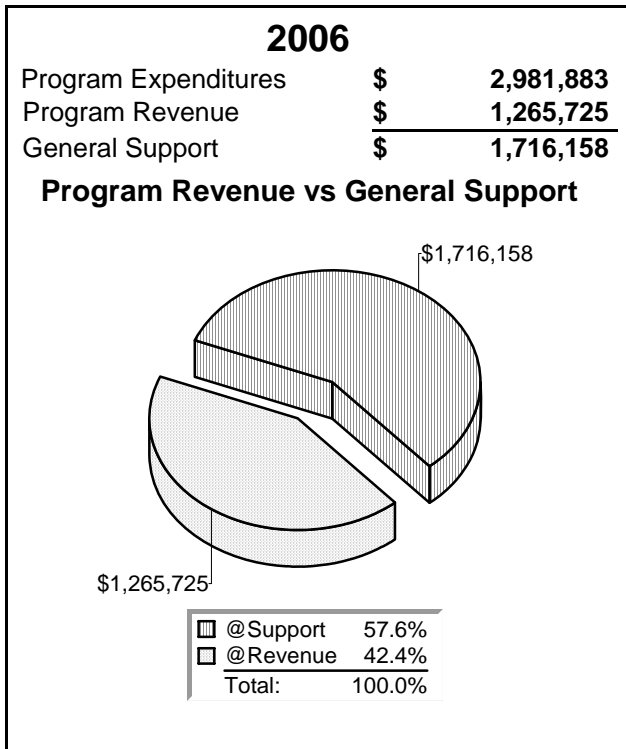

SURFACE WATER MANAGEMENT

PROGRAM PURPOSE:

The Surface Water Management program provides for the maintenance and operations of the City's surface and subsurface water infrastructure, public education and outreach, water quality monitoring and code enforcement to protect water quality, enhance natural habitat, and prevent flooding.

STRATEGIC OBJECTIVES:

Safe, Healthy and Sustainable Environment

Measurement: EFFECTIVENESS	2004	2005	2006	2007/Target
Percentage of catch basins cleaned annually	50%	50%	50%	50%
Percentage of citizens who are very satisfied or satisfied with the adequacy of storm drainage services in their neighborhood	55%	55%	75%	100%
Percentage of citizens who are very satisfied or satisfied with the overall quality of the City's stormwater system	55%	55%	75%	100%

Measurement: EFFICIENCY	2004	2005	2006	2007/Target
Cost per lane mile swept.	\$15.12	\$18.92	N/A	N/A

Measurement: WORKLOAD	2004	2005	2006	2007/Target
Approximate linear feet of stormwater pipes maintained	640,000	640,000	640,000	640,000
Approximate total linear feet of ditches maintained	150,000	150,000	150,000	150,000
City owned Storm Water Facilities inspected and maintained by the City	30	30	30	N/A
Number of catch basins cleaned	3,653	3,700	3,700	3,700
Number of dams inspected and maintained	6	5	5	5
Number of linear feet of open drainage channels cleared	1,114	977	1,000	1,000
Number of private retention/detention facility inspections	318	235	275	275
Number of pump stations maintained	4	4	5	5
Total number of catch basins maintained	7,117	7,200	7,200	7,200

SURFACE WATER MANAGEMENT

2006

Program Expenditures	\$	1,714,049
Program Revenue	\$	2,754,067
General Support	\$	(1,040,018)

Program Revenue vs General Support

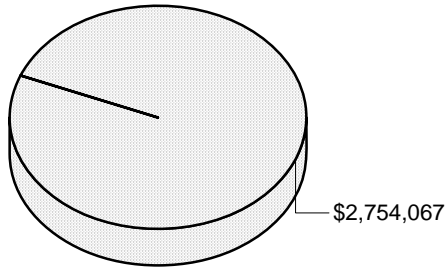

■	@Support	(27.4)%
□	@Revenue	72.6%
Total:		100.0%

2007

Program Expenditures	\$	1,672,867
Program Revenue	\$	2,100,529
General Support	\$	(427,662)

Program Revenue vs General Support

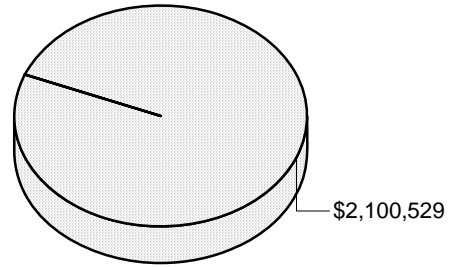

■	@Support	(16.9)%
□	@Revenue	83.1%
Total:		100.0%

TRAFFIC SERVICES & NEIGHBORHOOD TRAFFIC SAFETY

PROGRAM PURPOSE:

Responsible for plan review, design and approval of all traffic control devices including streetlights, crosswalks, signals, signs, striping, etc; maintenance of traffic-related records including accident reports and signage/crosswalk inventories; preparation and documentation of city traffic standards; traffic counts and investigations and community education.

Provide traffic counts and investigations, community education, and management of the City's Neighborhood Traffic Safety Program (NTSP). Design traffic calming solutions that enhance the quality of life for Shoreline residents. Provide funding for special emphasis police traffic enforcement.

STRATEGIC OBJECTIVES:

Quality Services, Facilities and Infrastructure

Measurement: EFFECTIVENESS	2004	2005	2006	2007/Target
Percentage of citizens surveyed who are very satisfied or somewhat satisfied with the flow of traffic and congestion.	41%	41%	N/A	N/A
Percentage of services requests completed on time.	90%	95%	95%	100%

Measurement: WORKLOAD	2004	2005	2006	2007/Target
Number of active residential areas involved in the NTSP Program	45	38	42	42
Number of residential area traffic projects completed per year	7	25	50	25
Number of service requests received	104	132	221	150
Number of targeted law enforcement hours in a NTSP residential area.	946	954	950	950
Number of traffic counts completed each year	382	308	350	350
Number of work orders issued	350	329	350	350

TRAFFIC SERVICES & NEIGHBORHOOD TRAFFIC SAFETY

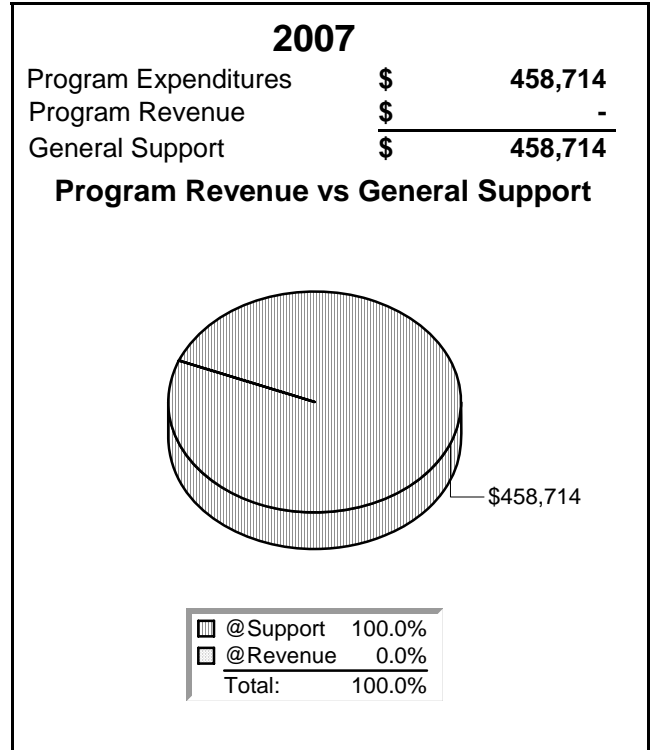
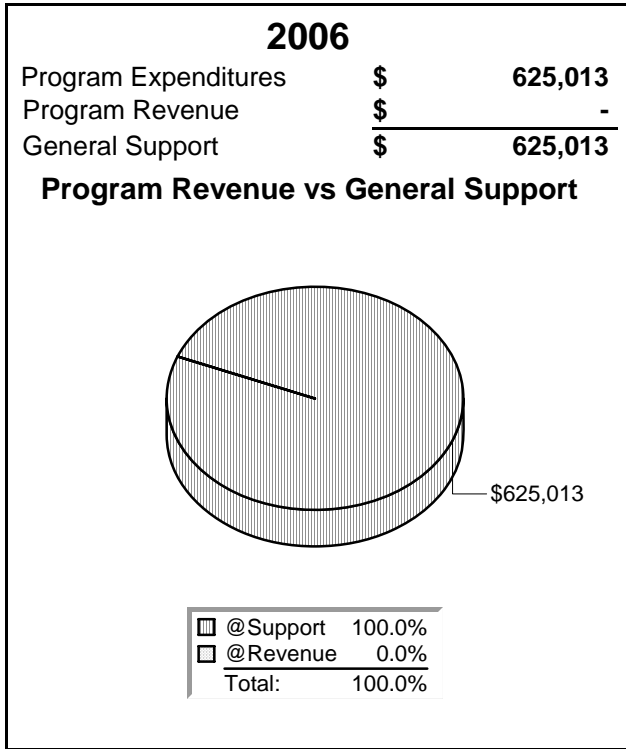

PUBLIC FACILITY & VEHICLE MAINTENANCE & OPERATIONS

PROGRAM PURPOSE:

The Facilities Program manages and maintains the City's owned and leased buildings and vehicles keeping them in good working order to provide services to citizens and to promote good stewardship of City of Shoreline's assets

STRATEGIC OBJECTIVES:

Quality Services, Facilities and Infrastructure

Measurement: EFFECTIVENESS	2004	2005	2006	2007/Target
Percentage of internal customers rating Facilities overall services as good or excellent			96%	
Percentage of internal customers rating Fleet Maintenance overall services as good or excellent			85%	

Measurement: EFFICIENCY	2004	2005	2006	2007/Target
Cost per square foot to maintain	\$10.21	\$10.67	\$3.32	\$2.91
Fleet maintenance cost per mile - vehicles and light trucks	N/A	\$0.15	\$0.22	\$0.22
Fleet maintenance cost per mile -heavy-duty trucks and equipment	N/A	\$0.65	\$1.58	\$1.25
Number of square feet maintained (facilities) per FTE	32,370	47,953	76,845	76,845
Percentage of work orders that are fully completed on time		100%	100%	100%
Total contracted custodial expenditures per square foot for administrative/office facilities		\$1.29	\$1.22	\$1.28
Total in-house custodial expenditures per square foot for administrative/office facilities		\$0.09	\$0.04	\$0.05
Total maintenance and preventative maintenance per vehicle for all heavy equipment		\$8.86	\$8.90	\$8.90

PUBLIC FACILITY & VEHICLE MAINTENANCE & OPERATIONS

2006

Program Expenditures	\$	1,151,833
Program Revenue	\$	88,717
General Support	\$	1,063,116

Program Revenue vs General Support

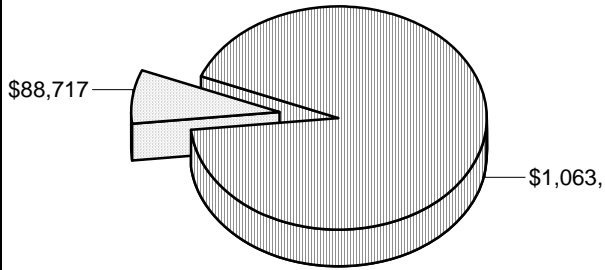

@Support	92.3%
@Revenue	7.7%
<hr style="border: none; border-top: 1px solid black;"/>	
Total:	100.0%

2007

Program Expenditures	\$	907,389
Program Revenue	\$	139,988
General Support	\$	767,401

Program Revenue vs General Support

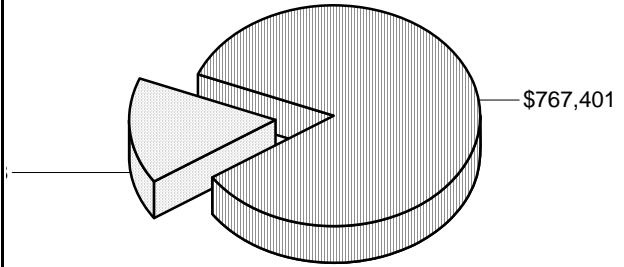

@Support	84.6%
@Revenue	15.4%
<hr style="border: none; border-top: 1px solid black;"/>	
Total:	100.0%

PUBLIC WORKS ADMINISTRATION

PROGRAM PURPOSE:

Public Works Administration provides the department with overall management, leadership, grants and contract administration, process and policy development.

STRATEGIC OBJECTIVES:

Quality Services, Facilities and Infrastructure

Measurement: EFFECTIVENESS	2004	2005	2006	2007/Target
Percentage of invoices processed on time			100%	100%

Measurement: EFFICIENCY	2004	2005	2006	2007/Target
Public Works Administration as a percent of the total Public Works Budget	3.0%	<5.0%	<4.0%	<5.0%

Measurement: WORKLOAD	2004	2005	2006	2007/Target
Number of grant reimbursements processed	23	41	60	60
Number of vendor invoices processed	5,322	2,984	2,900	2,950
Total number of contracts processed	134	147	156	150
Total number of easements processed	157	39	15	20
Total number of interlocals processed	3	9	15	15

PUBLIC WORKS ADMINISTRATION

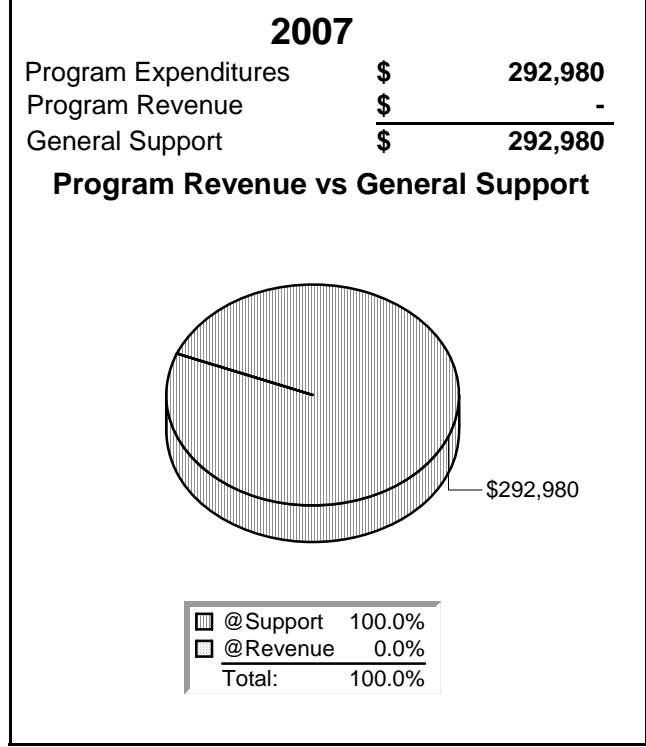
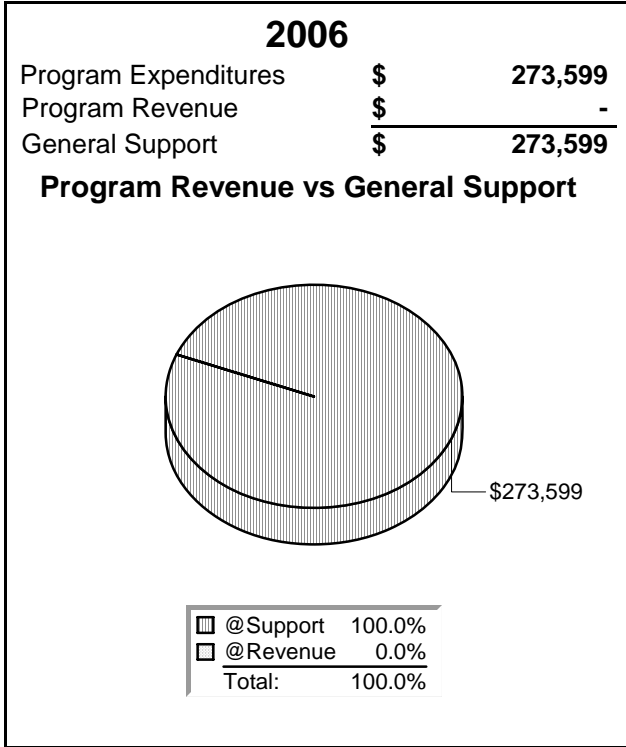



This Page Has Been Intentionally Left Blank



BUDGET BY FUND

City Fund Structure

Fund Structure

The City has established a variety of funds that are used to collect revenues and hold funds in reserve for specified purposes. The City has four categories of funds; operating, capital, internal service and agency. Operating funds collect a variety of revenues to support the City's various functions. Capital funds receive designated revenues and transfers-in from other funds to be used for specific capital projects. Internal service funds account for the goods and services provided internally on a cost-reimbursement basis. The City provides fiscal agency services to the Northshore/Shoreline Community Network. These transactions are reflected in an agency fund.

In 2007, the General Fund will continue to be the City's largest fund accounting for 41.68% of the City's total budget. The City's other funds in order of size are:

- General Capital Fund (34.73%),
- Roads Capital Fund (10.61%),
- Surface Water Utility Fund (8.72%),
- Street Fund (3.55%),
- Vehicle Operations & Maintenance Fund (0.21%),
- City Facility – Major Maintenance Fund (0.16%)
- Equipment Replacement Fund (0.15%),
- Code Abatement Fund (0.15%),
- Asset Seizure Fund (0.03%),
- Unemployment Fund (0.01%),
- General Reserve Fund and Public Art Fund (0.0%)

Fund Name	Description
Fund 001 General Fund	<u>Operating Funds</u> The General Fund is used to pay the expenses and liabilities of the City associated with general service functions that are not budgeted in special revenue funds. The primary sources of revenue are local taxes. Property tax and sales tax combined provide approximately 49% of the General Fund operating revenues.
<u>Special Revenue Funds</u>	Funds that include dedicated revenues for a specific purpose (e.g. roads, surface water management, etc.), that require an additional level of accountability and are collected in a separate account.
Funds 101 Street Fund	The Street Fund is used to support roads and transportation programs. Fuel tax and a subsidy from the General Fund are the two sources of on-going support.
Fund 103 Surface Water Management Fund	The Surface Water Management Fund was used to support the City drainage program. Beginning in 2006 these activities are reported in the Surface Water Utility Fund.
Fund 104 General Reserve Fund	The General Reserve Fund is used to provide for temporary financing of unforeseen needs of an emergency nature, adverse changes in the economic environment, and to facilitate the orderly adjustment to changes resulting from termination of revenue sources through actions of other governmental bodies. The resources in the General Reserve Fund will be kept in reserve until a defined need has been presented to/and adopted by the City Council.
Fund 107 Code Abatement Fund	The purpose of this Fund is to provide funding for City code abatement efforts (public nuisances, dangerous buildings, etc.). The costs associated with the abatement will be charged to the owner of the property either as a lien on the property or on the tax bill. Recovered monies would replenish the Fund for future abatement efforts.
Fund 108 Asset Seizure Fund	The purpose of this fund is to account for Federal and State seizure funds received by the City.

Fund 109 Public Arts Fund	The purpose of this fund is to account for the 1% for Arts program. An amount equal to 1% of capital construction contracts will be transferred from each capital fund. Funding will be utilized for public art projects.
<u>Capital Funds</u>	Funds that are specifically designated for major capital improvements.
Fund 301 General Capital Fund	The General Capital Fund receives funds that are designated specifically for capital purposes. The primary source of dedicated revenue is Real Estate Excise Tax (REET) and General Fund transfers. These funds are used for facility, recreation, parks and open space projects.
Fund 312 City Facility- Major Maintenance Fund	This fund was established in 2005. This capital fund will account for the long-term maintenance of City Facilities.
Fund 330 Roads Capital Fund	The Roads Capital Fund receives funds that are designated specifically for capital purposes. The primary source of dedicated revenue is Real Estate Excise Tax (REET) and federal, state, and local grant sources. These funds are used for street and transportation related projects.
Fund 340 Surface Water Capital Fund	The Surface Water Capital Fund was used to support the City drainage program. Beginning in 2006 these activities are reported in the Surface Water Utility Fund.
<u>Enterprise Fund</u>	
Fund 401 Surface Water Utility Fund	This fund includes all operations and capital improvements related to surface water management and drainage. The City charges property owners an annual surface water fee that is used to fund these activities.
<u>Internal Service Funds</u>	A type of proprietary fund which accounts for the goods and services which are provided to other units of the City and payment by the benefiting unit is intended to fund the costs of providing the services.
Fund 501 Vehicle Operations and Maintenance Fund	The Vehicle Operations and Maintenance Fund accounts for the costs of operating and maintaining city vehicles and auxiliary equipment. An annual charge is made to department budgets using City vehicles to support this purpose.
Fund 503 Equipment Replacement Fund	The Equipment Replacement Fund is used to account for the future replacement of all City assets, including purchased vehicles, computer equipment, furniture, buildings, other equipment, etc. An annual allocation is charged to departments for the replacement of vehicles and other equipment.
Fund 505 Unemployment Fund	An annual allocation is made to this Fund in lieu of making contributions to State unemployment insurance. In 2006, \$10,000 will be transferred from the General Fund to this Fund. These funds will be used to pay unemployment benefits to qualified City employees.
<u>Agency Fund</u>	Used to account for assets held by a government as an agent for individuals, private organizations, other government agencies and/or other funds.
Fund 651 Northshore / Shoreline Community Network	The city provides fiscal agency services through an interlocal agreement to the Northshore/Shoreline Community Network. The network's Executive Board retains complete control over the day-to-day administrative activities. This fund is custodial in nature and does not involve the measurement of results of operations. Therefore, the City does not appropriate a budget for this fund.

All Funds Historical Revenue/Expenditure Summary

	2004	Actuals	2005	Actuals	2006 Current		2007 Proposed		2006 Current
					Budget	2006 Projected	Budget	Proposed Budget	Budget vs. 2007
RESOURCES									
Beginning Fund Balance	\$ 41,160,152		\$ 44,810,019		\$ 35,972,706	\$ 45,372,334	\$ 39,047,488	\$	3,074,782
Revenues & Transfers-In									
General Fund	\$ 26,627,955	\$ 27,805,737	\$ 27,257,636	\$ 27,026,615	\$ 27,775,480				517,844
Street Fund	2,333,147	2,384,846	2,469,877	2,530,230	2,302,087				(167,790)
Arterial Street Fund	348,124	391,928	-	-	-				-
Surface Water Management Fund	2,507,159	-	-	-	-				-
General Reserve Fund	201,614	189,350	38,350	122,301	58,546				20,196
Development Services Fund	1,678,203	-	-	-	-				-
Code Abatement Fund	9,738	100,312	102,500	49,212	82,500				(20,000)
Asset Seizure Fund	3,831	10,774	23,500	18,803	23,500				-
Public Art Fund	37,602	232,827	33,892	49,148	-				(33,892)
General Capital Fund	1,447,140	5,630,859	13,183,259	23,078,761	14,930,580				1,747,321
City Facility -Major Maintenance Fund	-	244,549	74,680	76,429	77,972				3,292
Roads Capital Fund	7,397,891	15,875,942	27,711,789	28,121,540	5,883,505				(21,828,284)
Surface Water Capital Fund	2,080,000	-	-	-	-				-
Surface Water Utility Fund		3,802,545	6,134,082	3,885,297	5,339,508				(794,574)
Vehicle Operations Fund	58,705	73,950	88,717	100,782	139,988				51,271
Equipment Replacement Fund	298,927	307,149	299,308	336,810	315,569				16,261
Unemployment Fund	42,767	13,229	10,450	32,300	10,500				50
Total Revenues & Transfers-In	\$ 45,072,803	\$ 57,063,997	\$ 77,428,040	\$ 85,428,228	\$ 56,939,735	\$	(20,488,305)		
Total Resources	\$ 86,232,955	\$ 101,874,015	\$ 113,400,746	\$ 130,800,562	\$ 95,987,223	\$	(17,413,523)		
USES									
Expenditures & Transfers Out									
General Fund	\$ 24,120,530	\$ 29,465,987	\$ 29,398,166	\$ 29,317,275	\$ 28,426,981	\$	(971,185)		
Street Fund	2,392,231	2,224,956	2,559,651	2,513,556	2,422,087		(137,564)		
Arterial Street Fund	347,753	348,545	-	-	-		-		
Surface Water Management Fund	1,920,344	-	-	-	-		-		
General Reserve Fund	-	-	-	-	-		-		
Development Services Fund	1,691,122	-	-	-	-		-		
Code Abatement Fund	19,729	19,717	100,000	100,000	100,000		-		
Asset Seizure Fund	653	9,387	23,000	6,694	23,500		500		
Public Art Fund	-	15,000	115,775	115,775	-		(115,775)		
General Capital Fund	804,454	1,510,378	18,951,460	22,946,344	23,691,223		4,739,763		
City Facility -Major Maintenance Fund	-	83,826	60,000	60,000	110,000		50,000		
Roads Capital Fund	7,555,530	18,020,887	34,488,919	33,386,878	7,233,434		(27,255,485)		
Surface Water Capital Fund	2,339,286	-	-	-	-		-		
Surface Water Utility Fund	-	4,523,081	6,925,039	3,069,835	5,948,957		(976,082)		
Vehicle Operations Fund	67,469	78,981	88,717	88,717	139,988		51,271		
Equipment Replacement Fund	126,093	223,907	138,180	118,000	100,000		(38,180)		
Unemployment Fund	37,743	15,425	10,000	30,000	10,000		-		
Total Expenditures & Transfers Out	\$ 41,422,937	\$ 56,540,077	\$ 92,858,907	\$ 91,753,074	\$ 68,206,170	\$	(24,652,737)		
Ending Fund Balance	\$ 44,810,019	\$ 45,333,936	\$ 20,541,839	\$ 39,047,489	\$ 27,781,053	\$	7,239,214		
Total Uses	\$ 86,232,956	\$ 101,874,013	\$ 113,400,746	\$ 130,800,563	\$ 95,987,223	\$	(17,413,523)		

General Fund (001) Summary

The General Fund is used to pay the expenses and liabilities of the City associated with general service functions that are not budgeted in special revenue funds. The primary sources of revenue are general purpose State and local taxes. Property tax and sales tax combined equal approximately 50% of the General Fund operating revenues. Beginning in 2005, this fund will also include all permitting activities which have previously been recorded in the Development Services Fund (105).

Department: Various
Program: Various

	2003 Actuals	2004 Actuals	2005 Actuals	2006 Current Budget	2006 Projected	2007 Proposed Budget	2006 Current Budget vs. 2007 Proposed Budget	Percent Change
Beginning Fund Balance*	\$ 9,040,152	\$ 8,428,580	\$ 11,345,260	\$ 7,815,669	\$ 9,685,010	\$ 7,394,350	\$ (421,319)	-5%
Funding Sources								
Budgeted Beg. Fund Balance		\$ -		\$ 2,140,529		\$ 651,500	\$ (1,489,029)	-70%
Taxes	18,481,625	19,415,271	\$19,983,041	19,675,102	19,149,304	19,891,182	216,080	1%
Licenses & Permits	2,454,238	2,587,963	\$2,570,032	3,383,665	2,578,822	2,668,460	(715,205)	-21%
Intergovt. Revenues	1,266,908	1,161,657	\$2,217,007	1,086,380	2,100,694	2,025,620	939,240	86%
Charges for Goods and Service	714,991	777,523	\$1,444,612	1,446,452	1,537,039	1,601,517	155,065	11%
Fines and Forfeits	176,890	127,850	\$46,891	11,000	12,901	10,000	(1,000)	-9%
Misc. Revenues	251,550	315,196	\$383,564	451,196	444,014	532,254	81,058	18%
Total Revenue	\$ 23,346,202	\$ 24,385,460	\$ 26,645,147	\$ 28,194,324	\$ 25,822,774	\$ 27,380,533	\$ (813,791)	-3%
Transfers From Other Funds	2,160,896	2,242,495	1,160,590	1,203,841	1,203,841	1,046,447	(157,394)	-13%
Total Funding Sources	\$ 25,507,098	\$ 26,627,955	\$ 27,805,737	\$ 29,398,165	\$ 27,026,615	\$ 28,426,980	\$ (971,185)	-3%
Use of Funds								
Salaries & Wages	\$ 5,206,116	\$ 5,455,604	\$ 6,498,453	\$ 7,160,823	\$ 6,903,667	\$ 7,528,413	\$ 367,590	5%
Personnel Benefits	1,331,102	1,397,433	1,682,992	1,913,046	1,898,458	2,260,572	347,526	18%
Supplies	576,924	477,191	600,454	487,025	529,424	504,668	17,643	4%
Other Services & Charges	4,548,369	4,278,373	4,850,125	5,511,243	5,677,409	5,030,415	(480,828)	-9%
Intergovt. Services	7,329,449	8,080,611	8,398,038	9,035,514	9,338,476	9,777,378	741,864	8%
Capital Outlays	134,501	82,523	26,664	112,651	170,531	16,500	(96,151)	
Interfund Payments/Transfers	6,992,209	4,348,795	7,409,261	5,177,864	4,799,310	3,309,035	(1,868,829)	-36%
Total Expenditures	\$ 26,118,670	\$ 24,120,530	\$ 29,465,987	\$ 29,398,166	\$ 29,317,275	\$ 28,426,981	\$ (971,185)	-3%
Ending Fund Balance	\$ 8,428,580	\$ 10,936,005	\$ 9,685,010	\$ 5,675,139	\$ 7,394,350	\$ 6,742,849	\$ 1,067,710	19%

*The Fund Balance of the Arterial Street Fund was transferred to the General Fund at the end of 2004.

Total FTE's	90.95	94.23	107.07	110.18	111.18	112.43	2.25	2%
--------------------	-------	-------	--------	--------	--------	--------	------	----

2007 Funding Sources

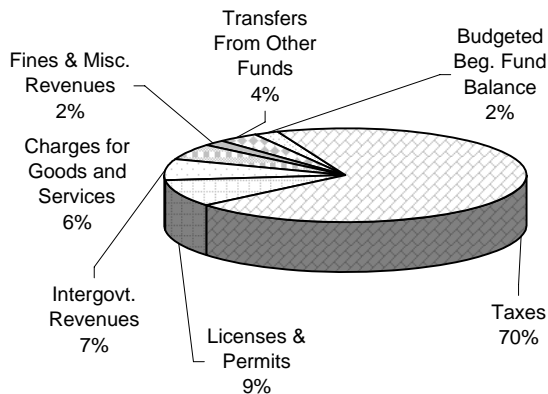

2007 Use of Funds

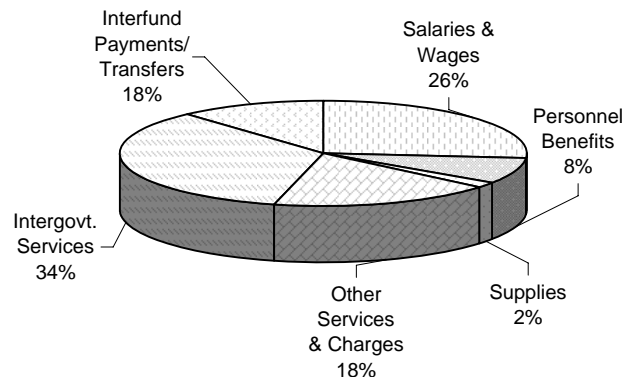

Street Fund (101) Summary

The Street Fund provides support for roads and transportation maintenance and right of way activities. Fuel tax is the major source of revenue. Funds are transferred from the General Fund to subsidize the Street Operations program.

Department: Public Works
Programs: Right of Way Permit & Inspection
 Street Operations
 Traffic Services

	2003 Actuals	2004 Actuals	2005 Actuals	2006 Current Budget	2006 Projected	2007 Proposed Budget	2006 Current Budget vs. 2007 Proposed Budget	Percent Change
Beginning Fund Balance	\$ 814,688	\$ 677,763	\$ 618,679	\$ 527,103	\$ 778,568	\$ 795,243	\$ 268,140	51%
Funding Sources								
Budgeted Beg. Fund Balance	\$ -		\$ -	\$ 89,774		\$ 120,000	\$ 30,226	34%
Licenses & Permits	114,814	103,132	213,514	111,469	111,469	120,000	8,531	8%
Intergovt. Revenues	827,100	745,102	742,372	771,277	763,789	746,966	(24,311)	-3%
Fines and Forfeits	25	67	-	-	11	-	-	
Misc. Revenues	66,103	19,082	17,270	22,000	72,354	35,000	13,000	59%
Total Revenue	\$ 1,008,042	\$ 867,383	\$ 973,156	\$ 994,520	\$ 947,623	\$ 1,021,966	\$ 27,446	3%
Transfers From Other Funds	1,730,882	1,465,764	1,411,690	1,565,131	1,582,607	1,400,121	(165,010)	-11%
Total Funding Sources	\$ 2,738,924	\$ 2,333,147	\$ 2,384,846	\$ 2,559,651	\$ 2,530,230	\$ 2,422,087	\$ (137,564)	-5%
Use of Funds								
Salaries & Wages	\$ 565,084	\$ 525,780	\$ 604,741	\$ 660,394	\$ 633,558	\$ 696,309	\$ 35,915	5%
Personnel Benefits	165,948	158,338	176,488	198,526	190,289	233,863	35,337	18%
Supplies	96,345	134,157	125,976	74,869	113,301	123,800	48,931	65%
Other Services & Charges	565,414	444,940	259,387	496,883	421,895	466,088	(30,795)	-6%
Intergovt. Services	396,899	309,409	326,425	295,651	312,034	169,940	(125,711)	-43%
Capital Outlays	115,021	-	2,388	-	10,000	90,000	90,000	
Interfund Payments for Service	971,138	819,607	729,551	833,328	832,479	642,087	(191,241)	-23%
Total Expenditures	\$ 2,875,849	\$ 2,392,231	\$ 2,224,956	\$ 2,559,651	\$ 2,513,556	\$ 2,422,087	\$ (137,564)	-5%
Ending Fund Balance	\$ 677,763	\$ 618,679	\$ 778,568	\$ 437,329	\$ 795,243	\$ 675,243	\$ 237,914	54%
Total FTE's	14.05	11.98	12.15	12.05	12.05	12.05	-	0%

2007 Funding Sources

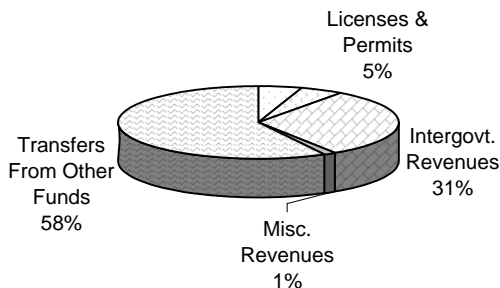

2007 Use of Funds

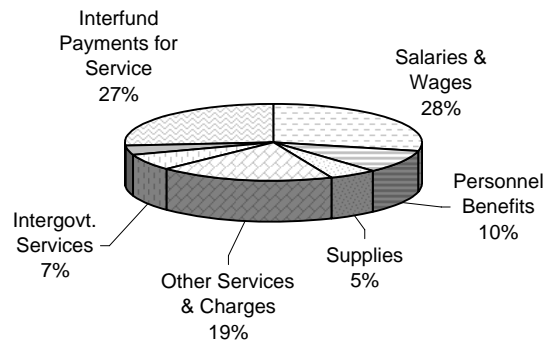

Arterial Street Fund (102) Summary

The Arterial Street Fund provides funding for roads and transportation capital projects. The major source of revenue is fuel tax that is designated for road and transportation improvements. Fuel tax revenues received by this fund are transferred to the Roads Capital Fund.

Department: Public Works
 Program: Administrative Transfers

	2003 Actuals	2004 Actuals	2005 Actuals	2006 Current Budget	2006 Projected	2007 Proposed Budget	2006 Current Budget vs. 2007 Proposed Budget	Percent Change
Beginning Fund Balance	\$ -	\$ 15,164	\$ 15,535	\$ -	\$ -	\$ -	\$ -	0.00%
Funding Sources								
Budgeted Beginning Fund Balance								
Taxes								
Licenses & Permits								
Intergovt. Revenues	\$ 354,309	\$ 345,972	\$ 347,109	\$ -	\$ -	\$ -	\$ -	0.00%
Charges for Goods and Services								
Fines and Forfeits								
Misc. Revenues	580	2,152	44,819	-	-	-	-	
Total Revenue	\$ 354,889	\$ 348,124	\$ 391,928	\$ -	\$ -	\$ -	\$ -	0.00%
Transfers From Other Funds								
Total Funding Sources	\$ 354,889	\$ 348,124	\$ 391,928	\$ -	\$ -	\$ -	\$ -	0.00%
Use of Funds								
Interfund Payments for Service	\$ 339,726	\$ 347,753	\$ 348,545	\$ -	\$ -	\$ -	\$ -	0.00%
Total Expenditures	\$ 339,726	\$ 347,753	\$ 348,545	\$ -	\$ -	\$ -	\$ -	0.00%
Ending Fund Balance	\$ 15,164	\$ 15,535	\$ 58,918	\$ -	\$ -	\$ -	\$ -	0%
Total FTE's	0.00	0.00	0.00	0.00	0.00	0.00	0.00	0.00

2007 Funding Sources

This fund was closed at the end of 2005.

2007 Use of Fund

This fund was closed at the end of 2005.

Surface Water Management Fund (103) Summary

The Surface Water Management Fund is used to support the City's drainage program. The major source of revenue for this fund is the storm drainage fees paid annually by Shoreline property owners. A portion of the fees are transferred to the Surface Water Capital Fund to support drainage improvement projects.

Department: Public Works
 Programs: Surface Water Management

	2003 Actuals	2004 Actuals	2005 Actuals	2006 Current Budget	2006 Projected	2007 Proposed Budget	2006 Current Budget vs. 2007 Proposed Budget	Percent Change
Beginning Fund Balance	\$ 2,370,539	\$ 2,399,475						
Funding Sources								
Budgeted Beg. Fund Balance	\$ -							
Intergovt. Revenues	-							
Charges for Goods and Services	2,496,894	2,446,302						
Misc. Revenues	18,832	60,857						
Total Revenue	\$ 2,515,726	\$ 2,507,159	\$ -	\$ -	\$ -	\$ -	\$ -	
Transfers From Other Funds								-
Total Funding Sources	\$ 2,515,726	\$ 2,507,159	\$ -	\$ -	\$ -	\$ -	\$ -	
Use of Funds								
Salaries & Wages	\$ 392,886	\$ 292,990						
Personnel Benefits	104,122	79,631						
Supplies	26,723	97,597						
Other Services & Charges	150,571	216,646						
Intergovt. Services	173,049	168,318						
Capital Outlays	-	9,357						
Debt Service*	51,998	237,908						
Interfund Payments for Service	1,587,441	817,897						
Total Expenditures	\$ 2,486,790	\$ 1,920,344	\$ -	\$ -	\$ -	\$ -	\$ -	
Ending Fund Balance	\$ 2,399,475	\$ 2,986,290	\$ -	\$ -	\$ -	\$ -	\$ -	
Total FTE's		7.13	5.72					

2007 Funding Sources

This fund was merged with Surface Water Capital Fund (340) into a new fund called Surface Water Utility Fund beginning 2005. This fund is being displayed for historical purposes only.

2007 Use of Funds

This fund was merged with Surface Water Capital Fund (340) into a new fund called Surface Water Utility Fund beginning 2005. This fund is being displayed for historical purposes only.

General Reserve Fund (104) Summary

The purpose of the General Reserve Fund is to maintain reserves to provide temporary financing of unforeseen needs of an emergency nature, adverse changes in the economic environment, and to facilitate the orderly adjustment to changes resulting from termination of revenue sources through actions of other governmental bodies. The fund was created in 1997 with a transfer from the General Fund.

According to RCW 35.33.145, the amount that can be set aside in a separate reserve fund cannot exceed thirty-seven and one-half cents per thousand dollars of assessed valuation. This limit for 2006 is \$2.3 million.

The General Reserve Fund when combined with the undesignated General Fund fund balance of \$6.7 million creates a total reserve of \$9 million, 32% of the projected General Fund operating revenues. City policy is to maintain a minimum reserve equal to 10% of budgeted General Fund funding sources

Department:
Program:

	2003 Actuals	2004 Actuals	2005 Actuals	2006 Current Budget	2006 Projected	2007 Proposed Budget	2006 Current Budget vs. 2007 Proposed Budget	Percent Change
Beginning Fund Balance	\$ 1,601,729	\$ 1,769,382	\$ 1,970,996	\$ 2,140,189	\$ 2,160,346	\$ 2,282,647	\$ 142,458	7%
Funding Sources								
Total Revenue							\$ -	
Miscellaneous Revenues	\$ 283	\$ 28,725	\$ 35,157	\$ -	\$ 83,951	\$ 58,546	\$ 58,546	
Transfers From Other Funds	\$ 167,370	\$ 172,889	\$ 154,193	\$ 38,350	\$ 38,350	\$ -	\$ (38,350)	-100%
Total Funding Sources	\$ 167,653	\$ 201,614	\$ 189,350	\$ 38,350	\$ 122,301	\$ 58,546	\$ (38,350)	-100%
Use of Funds	\$ -	\$ -	\$ -	\$ -	\$ -	\$ -	\$ -	
Total Expenditures							\$ -	
Ending Fund Balance	\$ 1,769,382	\$ 1,970,996	\$ 2,160,346	\$ 2,178,539	\$ 2,282,647	\$ 2,341,193	\$ 162,654	7%
Total FTE's	0.00		0.00	0.00	0.00	0.00	0.00	

2007 Funding Sources

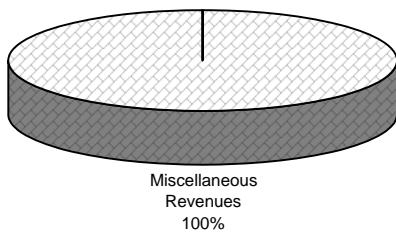

2007 Use of Funds

No Expenditures are being proposed for appropriation at this time.

Development Services Fund (105) Summary

The purpose of the Development Services Fund is to account for the permit fees collected. The beginning fund balance is comprised of a portion of prior year fees that are held in a reserve for future year services associated with multi-year construction permits. The General Fund provides support to this fund to supplement the fee revenue to support permitting activities. This fund was closed at the end of 2004 and all permitting activities will be recorded in the General Fund (001).

Department: Planning & Development Services
 Programs: Permit Services Team
 Building & Inspection Team

	2003 Actuals	2004 Actuals	2005 Actuals	2006 Current Budget	2006 Projected	2007 Proposed Budget	2006 Current Budget vs. 2007 Proposed Budget	Percent Change
Beginning Fund Balance	\$ 376,528	\$ 422,167						
Funding Sources								
Budgeted Beg. Fund Balance	\$ -							
Licenses & Permits	719,755	666,955						
Charges for Goods and Service:	386,276	353,847						
Misc. Revenues	3,204	6,040						
Total Revenue	\$ 1,109,235	\$ 1,026,842	\$ -	\$ -	\$ -	\$ -	\$ -	-
Transfers From Other Funds	665,470	651,361						
Total Funding Sources	\$ 1,774,705	\$ 1,678,203	\$ -	\$ -	\$ -	\$ -	\$ -	-
Use of Funds								
Salaries & Wages	\$ 718,262	\$ 727,413						
Personnel Benefits	188,136	193,492						
Supplies	11,695	16,639						
Other Services & Charges	36,273	40,002						
Intergovernmental Services	2,720	-						
Interfund Payments for Service	771,980	713,576						
Total Expenditures	\$ 1,729,066	\$ 1,691,122	\$ -	\$ -	\$ -	\$ -	\$ -	-
Ending Fund Balance	\$ 422,167	\$ 409,248	\$ -	\$ -	\$ -	\$ -	\$ -	-
Total FTE's	13.65	13.00						

2007 Funding Sources

No Revenues are being proposed for appropriation at this time. This fund was closed at the end of 2004. This fund is being displayed for historical purposes only.

2007 Use of Funds

No Expenditures are being proposed for appropriation at this time. This fund was closed at the end of 2004. This fund is being displayed for historical purposes only.

Code Abatement Fund (107) Summary

The Code Abatement Fund provides funding for City code abatement efforts (public nuisances, dangerous buildings, etc.). The costs associated with the abatement will be charged to the owner of the property either as a lien on the property or on the tax bill. Recovered monies would replenish the fund for future abatement efforts. This fund was established in 2002 by a transfer from the General Fund.

Department: Planning & Development Services
 Program: Code Abatement Operations

	2003 Actuals	2004 Actuals	2005 Actuals	2006 Current Budget	2006 Projected	2007 Proposed Budget	2006 Current Budget vs. 2007 Proposed Budget	Percent Change
Beginning Fund Balance	\$ 72,666	\$ 48,313	\$ 38,322	\$ 86,095	\$ 118,916	\$ 68,128	\$ (17,967)	-21%
Funding Sources								
Budgeted Beginning Fund Balance						\$ 17,500	\$ -	#DIV/0!
Fines and Forfeits	500		30,940		21,250		-	
Misc. Revenues	9	1,033	9,372	82,500	7,962	82,500	-	0%
Total Revenue	\$ 509	\$ 1,033	\$ 40,312	\$ 82,500	\$ 29,212	\$ 100,000	\$ -	0%
Other Financing/Transfers In		8,705	60,000	20,000	20,000	-	(20,000)	-100%
Total Funding Sources	\$ 509	\$ 9,738	\$ 100,312	\$ 102,500	\$ 49,212	\$ 100,000	\$ (20,000)	-20%
Use of Funds								
Supplies	23	147					-	
Other Services & Charges	13,700	10,499	19,717	100,000	100,000	100,000	-	0%
Capital Outlays	11,139	8,900					-	
Interfund Payments for Service		183					-	
Total Expenditures	\$ 24,862	\$ 19,729	\$ 19,717	\$ 100,000	\$ 100,000	\$ 100,000	\$ -	0%
Ending Fund Balance	\$ 48,313	\$ 38,322	\$ 118,916	\$ 88,595	\$ 68,128	\$ 50,628	\$ (37,967)	-43%
Total FTE's	0.00	0.00	0.00	0.00	0.00	0.00	0.00	0.00

2007 Funding Sources

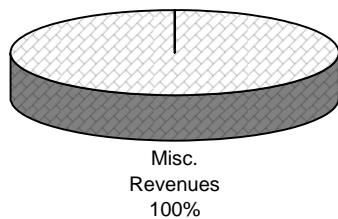

2007 Use of Funds

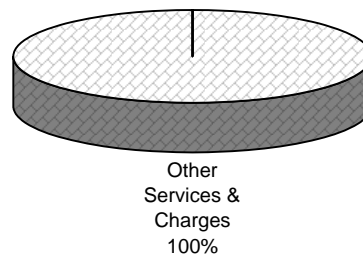

Asset Seizure Fund (108) Summary

The purpose of the Asset Seizure Fund is to account for Federal and State seizure funds received by the City. The use of these funds is restricted to purchases that will enhance the ability of the City's police to investigate drug related crimes and incidents.

Department: Police
 Program: State/Federal Seizures

	2003 Actuals	2004 Actuals	2005 Actuals	2006 Current Budget	2006 Projected	2007 Proposed Budget	2006 Current Budget vs. 2007 Proposed Budget	Percent Change
Beginning Fund Balance	\$ 27,638	\$ 17,157	\$ 20,335	\$ 25,558	\$ 21,722	\$ 33,831	\$ 8,273	32%
Funding Sources								
Misc. Revenues	5,391	3,831	10,774	23,500	18,803	23,500	-	0%
Total Revenue	\$ 5,391	\$ 3,831	\$ 10,774	\$ 23,500	\$ 18,803	\$ 23,500	\$ -	0%
Transfers From Other Funds							-	
Total Funding Sources	\$ 5,391	\$ 3,831	\$ 10,774	\$ 23,500	\$ 18,803	\$ 23,500	\$ -	0%
Use of Funds								
Supplies	\$ 15,317	\$ 653	\$ 454	\$ 23,000	\$ 2,694	\$ 23,500	\$ 500	2%
Other Services & Charges	555		4,333		4,000	-	-	
Intergovernmental Services			4,600				-	0%
Total Expenditures	\$ 15,872	\$ 653	\$ 9,387	\$ 23,000	\$ 6,694	\$ 23,500	\$ 500	2%
Ending Fund Balance	\$ 17,157	\$ 20,335	\$ 21,722	\$ 26,058	\$ 33,831	\$ 33,831	\$ 7,773	30%
Total FTE's	0.00	0.00	0.00	0.00	0.00	0.00	0.00	

2007 Funding Sources

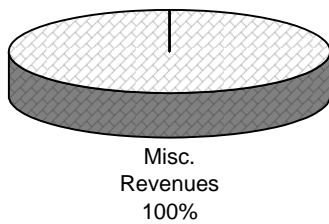

2007 Use of Funds

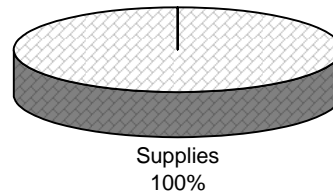

Public Arts Fund (109) Summary

The Public Arts Fund accounts for the 1% for Arts Program. An amount equal to 1% of annual capital construction is transferred from each capital fund into this fund. Funding will be utilized to support public art projects. Once the Parks and Recreation Advisory Committee develops the arts implementation program, the City will present a budget amendment to appropriate the fund's resources to be expended. Until that time, only the estimated revenues will be appropriated.

Department: Parks, Recreation, and Cultural Services
 Program: Public Arts Administration

	2003 Actuals	2004 Actuals	2005 Actuals	2006 Current Budget	2006 Projected	2007 Proposed Budget	2006 Current Budget vs. 2007 Proposed Budget	Percent Change
Beginning Fund Balance	\$ -	\$ 23,438	\$ 61,040	\$ 406,518	\$ 278,867	\$ 212,240	\$ (194,278)	-48%
Funding Sources								
Budgeted Beg. Fund Balance				\$ 115,775				0%
Miscellaneous Revenues		\$ 495	\$ 1,220	\$ -	\$ 15,256	\$ -		0%
Transfers From Other Funds	23,438	37,107	231,607	33,892	33,892	-	(33,892)	-100%
Total Funding Sources	\$ 23,438	\$ 37,602	\$ 232,827	\$ 149,667	\$ 49,148	\$ -	\$ (33,892)	-23%
Use of Funds								
Other Services & Charges			15,000				-	0%
Capital Outlays				115,775	115,775		(115,775)	-100%
Total Expenditures	\$ -	\$ -	\$ 15,000	\$ 115,775	\$ 115,775	\$ -	\$ (115,775)	-100%
Ending Fund Balance	\$ 23,438	\$ 61,040	\$ 278,867	\$ 324,635	\$ 212,240	\$ 212,240	\$ (112,395)	-35%
Total FTE's	0.00	0.00	0.00	0.00	0.00	0.00	0.00	

2007 Funding Sources

No Funding is being proposed for appropriation at this time.

2007 Use of Funds

No Expenditures are being proposed for appropriation at this time.

General Capital Fund (301) Summary

The General Capital Fund receives resources that are designated specifically for capital purposes. The primary on-going dedicated resource is real estate excise tax (REET). Other revenue sources include General Fund support and dedicated project grants. Projects in the General Capital Fund are divided into three major categories: facilities projects, parks projects and open space projects. For a complete discussion of this fund refer to the Capital Improvement Program section of this document.

Department: Public Works
 Programs: General Capital Engineering
 General Capital Projects

	2003 Actuals	2004 Actuals	2005 Actuals	2006 Current Budget	2006 Projected	2007 Proposed Budget	2006 Current Budget vs. 2007 Proposed Budget	Percent Change
Beginning Fund Balance	\$ 4,260,437	\$ 7,337,406	\$ 7,980,092	\$ 7,871,969	\$ 12,100,573	\$ 12,232,990	\$ 4,361,021	55%
Funding Sources								
Budgeted Beg. Fund Balance	\$ -			\$ 5,843,201		\$ 8,760,643	\$ 2,917,442	50%
Taxes	851,457	1,008,081	1,337,816	712,674	850,000	355,000	(357,674)	-50%
Intergovt. Revenues	-	49,400	27,990	1,700,000	975,000	779,025	(920,975)	-54%
Charges for Goods and Service	561	138					-	
Misc. Revenues	42,212	143,871	265,053	425,847	684,023	685,555	259,708	61%
Financing Proceeds				9,800,000		12,750,000	2,950,000	30%
Total Revenue	\$ 894,230	\$ 1,201,490	\$ 1,630,859	\$ 18,481,722	\$ 2,509,023	\$ 23,330,223	\$ 4,848,501	26%
Transfers From Other Funds	3,045,650	245,650	4,000,000	544,738	20,569,738	361,000	(183,738)	-34%
Total Funding Sources	\$ 3,939,880	\$ 1,447,140	\$ 5,630,859	\$ 19,026,460	\$ 23,078,761	\$ 23,691,223	\$ 4,664,763	25%
Use of Funds								
Salaries & Wages	\$ 78,157	\$ 65,098	\$ 72,051	\$ 95,221	\$ 113,829	\$ 164,934	\$ 69,713	73%
Personnel Benefits	18,029	16,415	17,843	25,130	29,447	48,459	23,329	93%
Supplies	2,613	32,985	31,642	1,800	12,384	1,250	(550)	-31%
Other Services & Charges	260,062	187,454	182,268	1,466,800	1,030,572	767,434	(699,366)	-48%
Intergovt. Services	20,623	92,579	588,807	65,430	20,000	-	(65,430)	-100%
Capital Outlays	478,198	317,566	575,288	17,254,495	21,697,841	22,674,642	5,420,147	31%
Interfund Payments for Service	5,229	92,357	42,479	42,584	42,271	34,504	(8,080)	-19%
Total Expenditures	\$ 862,911	\$ 804,454	\$ 1,510,378	\$ 18,951,460	\$ 22,946,344	\$ 23,691,223	\$ 4,739,763	25%
Ending Fund Balance	\$ 7,337,406	\$ 7,980,092	\$ 12,100,573	\$ 2,103,768	\$ 12,232,990	\$ 3,472,347	\$ 1,368,579	65%
Total FTE's	1.05	0.81	0.90	0.90	1.48	2.23	1.33	148%

2007 Funding Sources

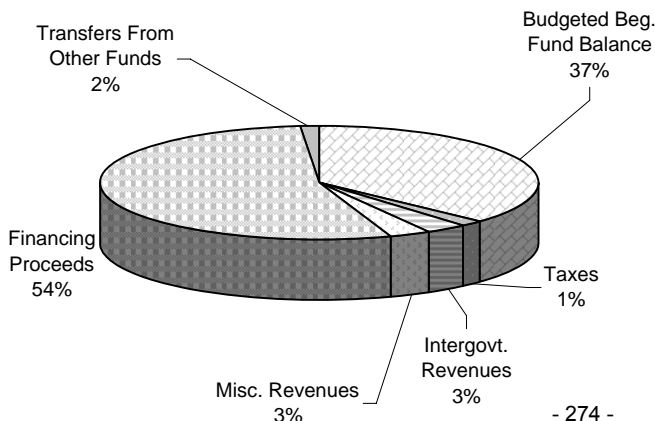

2007 Use of Funds

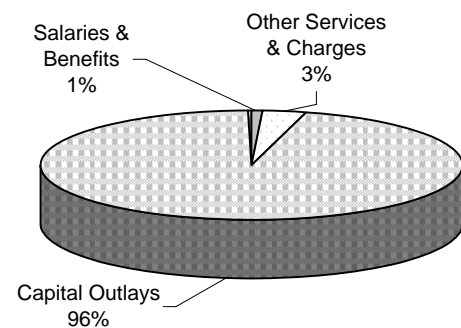

City Facility -Major Maintenance Fund (312) Summary

This fund was established in 2005. Projects in this capital fund will include major repairs and replacement of City facilities such as the police station, recreation centers and pool. The allocation of resources in this fund will be done through the City's capital improvement program.

Department: Public Works
 Program: Major Maintenance Projects

	2003 Actuals	2004 Actuals	2005 Actuals	2006 Current Budget	2006 Projected	2007 Proposed Budget	2006 Current Budget vs. 2007 Proposed Budget	Percent Change
Beginning Fund Balance				\$ 156,000	\$ 160,723	\$ 177,152	\$ 21,152	
Funding Sources								
Budgeted Beg. Fund Balance						\$ 32,028	\$ -	
Misc. Revenues			549	4,680	6,429	7,972	3,292	
Financing Proceeds							-	
Total Revenue	\$ -	\$ -	\$ 549	\$ 4,680	\$ 6,429	\$ 40,000	\$ 3,292	
Transfers From Other Funds			244,000	70,000	70,000	70,000	-	0%
Total Funding Sources	\$ -	\$ -	\$ 244,549	\$ 74,680	\$ 76,429	\$ 110,000	\$ 3,292	4%
Use of Funds								
Other Services & Charges							-	
Capital Outlays			83,826	60,000	60,000	110,000	50,000	83%
Total Expenditures	\$ -	\$ -	\$ 83,826	\$ 60,000	\$ 60,000	\$ 110,000	\$ 50,000	83%
Ending Fund Balance	\$ -	\$ -	\$ 160,723	\$ 170,680	\$ 177,152	\$ 145,124	\$ (25,556)	-15%
Total FTE's	0.00	0.00	0.00	0.00	0.00	0.00	0.00	

2007 Funding Sources

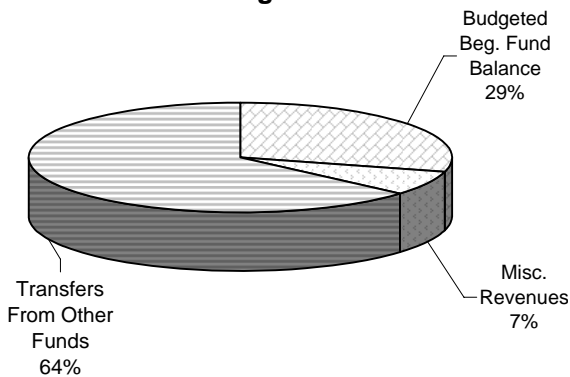

2007 Use of Funds

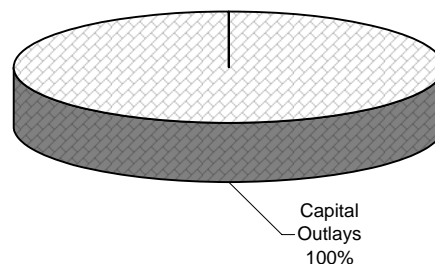

Roads Capital Fund (330) Summary

The Roads Capital Fund receives resources that are designated specifically for capital purposes. The primary on-going dedicated resource is real estate excise tax (REET). Other dedicated sources include fuel tax which is collected in the Arterial Street Fund and transferred to this fund and various project grants. Projects in the Roads Capital Fund are divided into three major categories: pedestrian/non-motorized projects, system preservation projects, and safety/operational projects. For a complete discussion of this fund refer to the Capital Improvement Program section of this document.

Department: Public Works
 Programs: Roads Capital Engineering
 Roads Capital Projects

	2003 Actuals	2004 Actuals	2005 Actuals	2006 Current		2007	2006 Current	Percent Change
				Budget	2006 Projected	Proposed Budget	Budget vs. 2007 Proposed Budget	
Beginning Fund Balance*	\$ 15,662,529	\$ 15,394,028	\$ 15,236,389	\$ 10,025,120	\$ 13,150,365	\$ 7,885,027	\$ (2,140,093)	-21%
Budgeted Beg. Fund Balance	\$ -		\$ -	\$ 6,777,129		\$ 1,349,929	\$ (5,427,200)	-80%
Taxes	851,456	1,008,514	1,337,816	712,674	1,100,000	870,000	157,326	22%
Licenses & Permits		613	450,578	-	105	-	-	0%
Intergovt. Revenues	1,649,384	4,260,964	12,187,991	24,539,423	24,922,336	4,030,312	(20,509,111)	-84%
Charges for Goods and Service	2,579	2,912	17,105	-	83,615	20,000	20,000	#DIV/0!
Misc. Revenues	121,391	240,426	257,973	588,875	624,214	350,191	(238,684)	-41%
Total Revenue	\$ 2,624,810	\$ 5,513,428	\$ 14,251,463	\$ 32,618,101	\$ 26,730,270	\$ 6,620,432	\$ (25,997,669)	-80%
Transfers From Other Funds	1,480,526	1,884,463	1,624,479	1,870,817	1,391,270	613,002	(1,257,815)	-67%
Total Funding Sources	\$ 4,105,336	\$ 7,397,891	\$ 15,875,942	\$ 34,488,918	\$ 28,121,540	\$ 7,233,434	\$ (27,255,484)	-79%
Use of Funds								
Salaries & Wages	\$ 296,338	\$ 572,841	\$ 744,903	\$ 712,080	\$ 775,789	\$ 706,593	\$ (5,487)	-1%
Personnel Benefits	67,681	137,773	181,633	184,340	198,420	205,461	21,121	11%
Supplies	40,165	60,379	66,894	6,261	48,908	1,295	(4,966)	-79%
Other Services & Charges	2,430,143	2,869,372	2,841,112	4,386,686	3,084,029	1,510,906	(2,875,780)	-66%
Intergovt. Services	16,395	199,157	63,117	1,533	50,636	2,000	467	30%
Capital Outlays	1,494,621	3,512,612	13,824,636	29,137,925	29,171,597	4,750,924	(24,387,001)	-84%
Interfund Payments for Service	28,494	203,396	298,592	60,094	57,499	56,255	(3,839)	-6%
Total Expenditures	\$ 4,373,837	\$ 7,555,530	\$ 18,020,887	\$ 34,488,919	\$ 33,386,878	\$ 7,233,434	\$ (27,255,485)	-79%
Ending Fund Balance	\$ 15,394,028	\$ 15,236,389	\$ 13,091,444	\$ 3,247,990	\$ 7,885,027	\$ 6,535,098	\$ 3,287,108	101%
Total FTE's	4.66	8.79	10.70	10.44	10.44	9.61	-0.83	-8%

*The Fund Balance of the Arterial Street Fund was transferred to the Roads Capital Fund at the end of 2005.

2007 Funding Sources

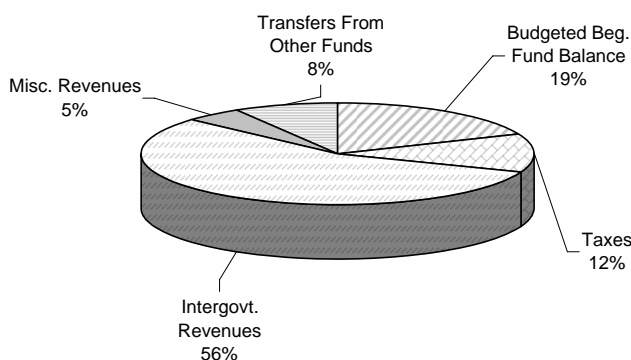

2007 Use of Funds

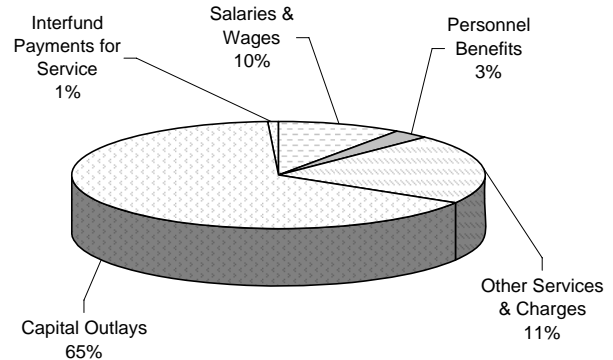

Surface Water Capital Fund (340) Summary

The Surface Water Capital Fund receives resources from the Surface Water Management Fund and from dedicated project grants. The projects in the Surface Water Capital Fund are divided into three categories: flood protection, water quality facilities and stream rehabilitation/habitat enhancement. For a complete discussion of this fund refer to the Capital Improvement Program section of this document.

Department: Public Works
 Programs: Surface Water Capital Engineering
 Surface Water Capital Projects

	2003 Actuals	2004 Actuals	2005 Actuals	2006 Current Budget	2006 Projected	2007 Proposed Budget	2006 Current Budget vs. 2007 Proposed Budget	Percent Change
Beginning Fund Balance	\$ 2,468,014	\$ 3,503,597						
Funding Sources								
Budgeted Beginning Fund Balance								
Intergovernmental Revenues								
Charges for Goods and Service:	1,440							
Misc. Revenues	26,197	118,074						
Other Financing Sources	506,431							
Total Revenue	\$ 534,068	\$ 118,074	\$ -	\$ -	\$ -	\$ -	\$ -	-
Other Financing/Transfers-In	1,083,024	1,961,926						
Total Funding Sources	\$ 1,617,092	\$ 2,080,000	\$ -	\$ -	\$ -	\$ -	\$ -	-
Use of Funds								
Salaries & Wages	\$ 30,647	\$ 145,521						
Personnel Benefits	7,281	37,619						
Supplies	300	4,153						
Other Services & Charges	445,912	628,338						
Intergovt. Services	363	188,865						
Capital Outlays	90,482	1,200,807						
Interfund Payments for Service	6,524	133,983						
Total Expenditures	\$ 581,509	\$ 2,339,286	\$ -	\$ -	\$ -	\$ -	\$ -	-
Ending Fund Balance	\$ 3,503,597	\$ 3,244,311	\$ -	\$ -	\$ -	\$ -	\$ -	-
	\$ -							
Total FTE's	1.66	3.40						

2007 Funding Sources

This fund was merged with Surface Water Management Fund (103) into a new fund called Surface Water Utility Fund beginning 2005. This fund is being displayed for historical purposes only.

2007 Use of Funds

This fund was merged with Surface Water Management Fund (103) into a new fund called Surface Water Utility Fund beginning 2005. This fund is being displayed for historical purposes only.

Surface Water Utility Fund (401) Summary

The Surface Water Management Fund is used to support the City's drainage program. The major source of revenue for this fund is the storm drainage fees paid annually by Shoreline property owners. A portion of the fees are transferred to the Surface Water Capital Fund to support drainage improvement projects.

Department: Public Works
 Programs: Surface Water Management
 Various Surface Water Capital Projects

	2003 Actuals *	2004 Actuals *	2005 Actuals	2006 Current Budget	2006 Projected	2007 Proposed Budget	2006 Current Budget vs. 2007 Proposed Budget	Percent Change
Beginning Fund Balance	\$ -	\$ -	\$ 6,230,601	\$ 5,440,548	\$ 5,548,451	\$ 6,363,913	\$ 923,365	17%
Funding Sources								
Budgeted Beg. Fund Balance	\$ -	\$ -	\$ -	\$ 2,894,015	\$ -	\$ 609,449	\$ (2,284,566)	-79%
Intergovt. Revenues	-	-	56,653	43,348	-	-	(43,348)	-100%
Charges for Goods and Service:	-	-	2,463,281	2,691,567	2,691,567	2,933,808	242,241	9%
Misc. Revenues	-	-	337,945	214,286	730,980	372,500	158,214	74%
Other Financing	-	-	944,666	-	437,750	2,033,200	-	-
Total Revenue	\$ -	\$ -	\$ 3,802,545	\$ 5,843,216	\$ 3,860,297	\$ 5,948,957	\$ (1,927,459)	-33%
Transfers From Other Funds	-	-	-	3,184,881	25,000	-	(3,184,881)	-100%
Total Funding Sources	\$ -	\$ -	\$ 3,802,545	\$ 9,028,097	\$ 3,885,297	\$ 5,948,957	\$ (5,112,340)	-57%
Use of Funds								
Salaries & Wages	\$ -	\$ -	\$ 488,801	\$ 637,666	\$ 575,837	\$ 701,282	\$ 63,616	10%
Personnel Benefits	-	-	122,662	172,020	155,942	204,667	32,647	19%
Supplies	-	-	89,241	84,275	98,864	80,288	(3,987)	-5%
Other Services & Charges	-	-	586,739	1,409,978	1,124,045	1,160,364	(249,614)	-18%
Intergovt. Services	-	-	440,552	374,683	409,675	268,374	(106,309)	-28%
Capital Outlays	-	-	2,033,716	371,331	256,701	2,716,644	2,345,313	632%
Debt Service*	-	-	343,611	345,450	345,539	350,900	5,450	2%
Interfund Payments for Service	-	-	417,759	3,529,636	103,232	466,438	(3,063,198)	-87%
Total Expenditures	\$ -	\$ -	\$ 4,523,081	\$ 6,925,039	\$ 3,069,835	\$ 5,948,957	\$ (976,082)	-14%
Ending Fund Balance	\$ -	\$ -	\$ 5,510,065	\$ 7,543,606	\$ 6,363,913	\$ 5,754,464		
**Adjusted Ending Fund Balance			\$ 5,548,451					
Total FTE's	0.00	0.00	8.90	10.08	10.08	10.15	0.07	1%

* This fund started in 2005 by merging Surface Water Management Fund (103) and Surface Water Capital Fund (340)

** Required year-end adjusting balance sheet entries resulted in an increase of \$38,386 to the ending fund balance.

2007 Funding Sources

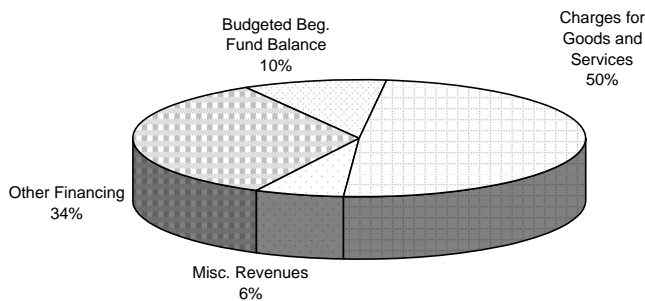

2007 Use of Funds

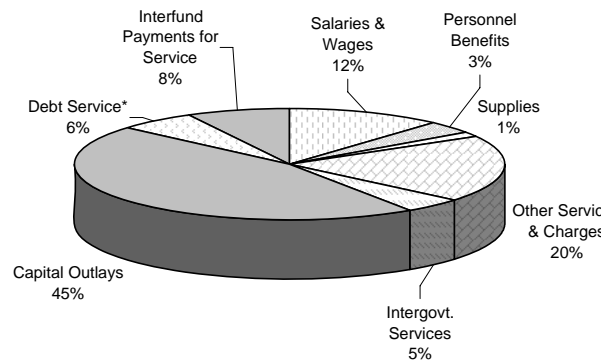

Vehicle Operations Fund (501) Summary

The Vehicle Operations and Maintenance Fund is used to account for the costs of operating and maintaining City vehicles and auxiliary equipment. Departments are assessed an annual charge for the estimated cost of the repair and maintenance of their vehicles along with projected fuel costs.

Department: Public Works
 Program: Vehicle Operations & Maintenance

	2003 Actuals	2004 Actuals	2005 Actuals	2006 Current Budget	2006 Projected	2007 Proposed Budget	2006 Current Budget vs. 2007 Proposed Budget	Percent Change
Beginning Fund Balance	\$ 70,593	\$ 61,366	\$ 52,602	\$ 52,134	\$ 47,572	\$ 59,637	\$ 7,503	14%
Funding Sources								
Misc. Revenues	41,920	58,705	73,950	88,717	99,532	139,988	51,271	1
Total Revenue	\$ 41,920	\$ 58,705	\$ 73,950	\$ 88,717	\$ 99,532	\$ 139,988	\$ 51,271	\$ 1
Transfers From Other Funds					1,250		-	
Total Funding Sources	\$ 41,920	\$ 58,705	\$ 73,950	\$ 88,717	\$ 100,782	\$ 139,988	\$ 51,271	58%
Use of Funds								
Supplies	\$ 22,033	\$ 36,185	\$ 49,364	\$ 44,625	\$ 49,625	\$ 75,863	\$ 31,238	70%
Other Services & Charges	29,084	31,284	29,617	44,092	39,092	64,125	20,033	45%
Intergovt. Services	30						-	
Capital Outlays							-	
Interfund Payments for Service							-	
Total Expenditures	\$ 51,147	\$ 67,469	\$ 78,981	\$ 88,717	\$ 88,717	\$ 139,988	\$ 51,271	58%
Ending Fund Balance	\$ 61,366	\$ 52,602	\$ 47,572	\$ 52,134	\$ 59,637	\$ 59,637	\$ 7,503	14%
Total FTE's	0.00	0.00	0.00	0.00	0.00	0.00	0.00	

2007 Funding Sources

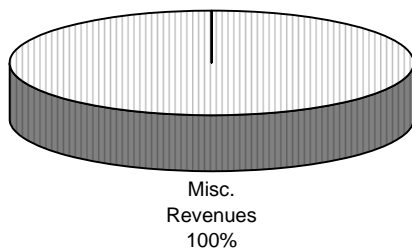

2007 Use of Funds

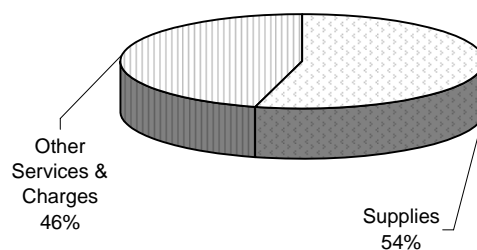

Equipment Replacement Fund (503) Summary

The Equipment Replacement Fund is used to account for the future replacement of City property. This includes replacement of vehicles, computers, servers and other related equipment. An annual transfer is made from the General Fund to support the replacement of all computer related equipment. Based upon the vehicle replacement schedule, departments are assessed an annual charge to cover the anticipated replacement cost for their vehicles.

Department: Finance
 Programs: Operational Equipment Replacement
 Technical

	2003 Actuals	2004 Actuals	2005 Actuals	2006 Current Budget	2006 Projected	2007 Proposed Budget	2006 Current Budget vs. 2007 Proposed Budget	Percent Change
Beginning Fund Balance	\$ 832,166	\$ 995,186	\$ 1,168,020	\$ 1,353,649	\$ 1,251,262	\$ 1,470,072	\$ 116,423	9%
Funding Sources								
Budgeted Beg. Fund Balance	\$ -		\$ -				\$ -	
Misc. Revenues	186,912	198,927	207,149	\$ 199,308	\$ 236,810	\$ 215,569	16,261	8%
Total Revenue	\$ 186,912	\$ 198,927	\$ 207,149	\$ 199,308	\$ 236,810	\$ 215,569	\$ 16,261	8%
Transfers From Other Funds	100,000	100,000	100,000	100,000	100,000	100,000	-	-
Total Funding Sources	\$ 286,912	\$ 298,927	\$ 307,149	\$ 299,308	\$ 336,810	\$ 315,569	\$ 16,261	5%
Use of Funds								
Supplies	\$ 41,103	\$ 86,262	\$ 99,725	\$ 58,600	\$ 48,000	\$ 36,000	\$ (22,600)	-39%
Capital Outlays	\$ 82,789	\$ 39,831	\$ 124,182	\$ 79,580	\$ 70,000	\$ 64,000	\$ (15,580)	-20%
Interfund Payments for Service							-	
Total Expenditures	\$ 123,892	\$ 126,093	\$ 223,907	\$ 138,180	\$ 118,000	\$ 100,000	\$ (38,180)	-28%
Ending Fund Balance	\$ 995,186	\$ 1,168,020	\$ 1,251,262	\$ 1,514,777	\$ 1,470,072	\$ 1,685,641	\$ 170,864	11%
Total FTE's	0.00	0.00	0.00	0.00	0.00	0.00	0.00	0.00

2007 Funding Sources

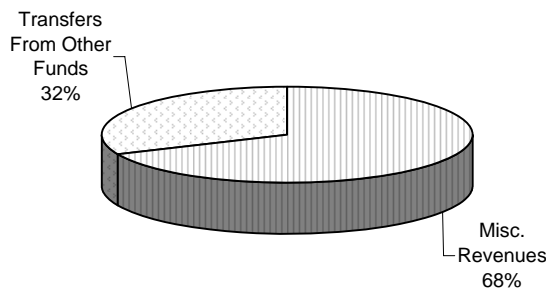

2007 Use of Funds

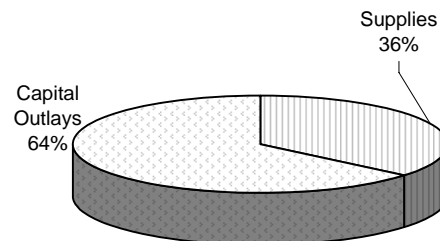

Unemployment Fund (505) Summary

An annual allocation is made to the Unemployment Fund in lieu of making contributions to state unemployment insurance. These funds are used to pay unemployment benefits for qualified City employees that leave City employment.

Department: Finance
 Program: Unemployment Administration

	2003 Actuals	2004 Actuals	2005 Actuals	2006 Current Budget	2006 Projected	2007 Proposed Budget	2006 Current Budget vs. 2007 Proposed Budget	Percent Change
Beginning Fund Balance	\$ 64,584	\$ 67,130	\$ 72,154	\$ 72,154	\$ 69,958	\$ 72,258	\$ 104	0%
Funding Sources								
Budgeted Beginning Fund Balance								
Miscellaneous Revenues	\$ 12	\$ 2,767	\$ 3,229	\$ 450	\$ 2,300	\$ 500	\$ 50	11%
Transfers From Other Funds	10,000	40,000	10,000	10,000	30,000	10,000	-	0%
Total Funding Sources	\$ 10,012	\$ 42,767	\$ 13,229	\$ 10,450	\$ 32,300	\$ 10,500	\$ 50	0%
Use of Funds								
Intergovt. Services	\$ 7,465	\$ 37,743	\$ 15,425	\$ 10,000	\$ 30,000	\$ 10,000	\$ -	0%
Total Expenditures	\$ 7,465	\$ 37,743	\$ 15,425	\$ 10,000	\$ 30,000	\$ 10,000	\$ -	0%
Ending Fund Balance	\$ 67,130	\$ 72,154	\$ 69,958	\$ 72,604	\$ 72,258	\$ 72,758	\$ 154	0%
Total FTE's	0.00	0.00					0.00	

2007 Funding Sources

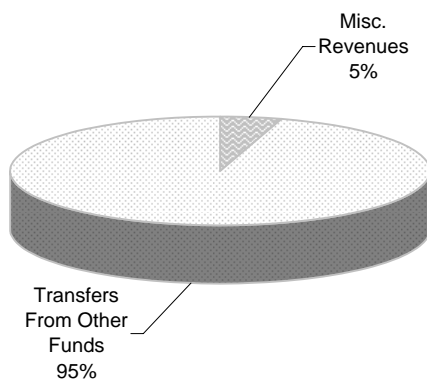

2007 Use of Funds

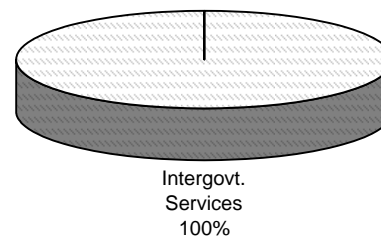



This Page Has Been Intentionally Left Blank

**Revenue and Expenditure Report for All Funds
2007 Budget**

Fund / Revenue	General Fund	Street Fund	General Capital Fund	Roads Capital Fund	Surface Water Enterprise Fund	General Reserve Fund	Equipment Replace. Fund	Vehicle Ops. & Maint. Fund	Unemploy. Fund	Code Abate. Fund	City Facility Major Maint Fund	Public Arts Fund	Asset Seizure Fund	Fund Totals
Beginning Fund Balance	\$7,394,350	\$795,243	\$12,232,990	\$7,885,027	\$6,363,913	\$2,282,647	\$1,470,072	\$59,637	\$72,258	\$68,128	\$177,152	\$212,240	\$33,831	\$39,047,488
Revenues														
Property Tax - City	\$7,066,510													\$7,066,510
Retail Sales - City	\$6,250,000													\$6,250,000
Retail Sales - Criminal Justice	\$1,224,500													\$1,224,500
Natural Gas Utility	\$1,045,000													\$1,045,000
Sanitation Utility	\$340,000													\$340,000
Cable TV Utility	\$98,000													\$98,000
Telephone/Cell Phone/Pagers Utility	\$1,555,000													\$1,555,000
Storm Drainage Utility	\$177,000													\$177,000
Leasehold Excise	\$672													\$672
Gambling Tax	\$2,134,500													\$2,134,500
Franchise Fee - Cable	\$530,000													\$530,000
Contract Payment - Electricity	\$1,000,000													\$1,000,000
Franchise Fee - Water	\$565,000													\$565,000
Franchise Fee - Sewer	\$655,595													\$655,595
Animal Licenses	\$200													\$200
State Police Chiefs	\$2,500													\$2,500
State - CJ - Violent Crime - Per Capita	\$11,663													\$11,663
State - CJ - City Law Enforce.	\$65,155													\$65,155
State - CJ - Special Programs	\$40,151													\$40,151
State-DUI /Criminal Justice Assistance	\$9,160													\$9,160
State Liquor Excise	\$225,199													\$225,199
State Liquor Profits	\$392,976													\$392,976
Court Fines/Forfeits	\$10,000													\$10,000
Investment Income	\$375,000	\$35,000	\$685,555	\$350,191	\$372,500	\$58,546	\$46,000	\$1,250	\$500	\$2,500	\$7,972		\$500	\$1,935,514
Sales Tax Interest	\$20,000													\$20,000
Miscellaneous Revenue	\$24,290							\$1,000						\$25,290
Business Licenses - Prof/Amusement	\$24,530													\$24,530
Business Registrations	\$90,000													\$90,000
Cable Franchise Reimbursements	\$3,767													\$3,767
Hearing Examiner Appeal Revenue	\$1,600													\$1,600
Financial/Accounting Services	\$1,800													\$1,800
Parks - Recreation Programs	\$508,182													\$508,182
Parks - Aquatics Revenues	\$354,050													\$354,050
Parks - Facility Rentals	\$235,000													\$235,000
Parks - Teen Programs	\$39,056													\$39,056
Parks - Operations	\$45,676													\$45,676
Parks - Cultural Services	\$22,000													\$22,000
Public Defense Reimbursements														
Parks														
Dedicated Revenue														
Capital Grants			\$300,000	\$3,439,000										\$3,739,000
Private Contributions-Capital Projects														
Utility Capital Reimbursement														
Storm Drainage Fees					\$2,933,808									\$2,933,808
Permits & Zoning Fees	\$1,292,335													\$1,292,335
Right-of-Way Permits		\$120,000												\$120,000
Real Estate Excise Tax (REET)			\$355,000	\$870,000										\$1,225,000
Vehicle Maint. & Operation Charges								\$137,738						\$137,738
Equipment Replacement Charges							\$169,569							\$169,569
King County Conservation Futures Grant			\$79,025											\$79,025
Interlocal Funding General	\$42,000		\$400,000											\$442,000
State Fuel Tax		\$746,966		\$591,312										\$1,338,278
General Obligation Bond Proceeds			\$12,750,000											\$12,750,000
Brightwater Mitigation														
Public Works Trust Fund Loan					\$2,033,200									\$2,033,200
In-Lieu Payments				\$20,000										\$20,000
Police Grants														
KC Community Organizing Comm	\$1,000													\$1,000
HS - Community Dev. Block Grant	\$125,306													\$125,306
City of Kenmore Transport Van Contract														

**Revenue and Expenditure Report for All Funds
2007 Budget**

Fund / Revenue	General Fund	Street Fund	General Capital Fund	Roads Capital Fund	Surface Water Enterprise Fund	General Reserve Fund	Equipment Replace. Fund	Vehicle Ops. & Maint. Fund	Unemploy. Fund	Code Abate. Fund	City Facility Major Maint Fund	Public Arts Fund	Asset Seizure Fund	Fund Totals
Public Works - Coord. Prevention Grant														
Public Works - Loc. Hz. Wst Grant	\$24,087													\$24,087
Public Works - COP/WRR	\$42,541													\$42,541
Recycling Proceeds	\$55,988													\$55,988
Code Abatement Revenue Recovery										\$80,000				\$80,000
Human Resources-Wellness Grant	\$1,500													\$1,500
Donations-Memorial														
Parks - Grants	\$544													\$544
Police - School District - SRO Participation														
Police - Asset Seizures													\$23,000	\$23,000
Total Revenues	\$26,729,033	\$901,966	\$14,569,580	\$5,270,503	\$5,339,508	\$58,546	\$215,569	\$139,988	\$500	\$82,500	\$7,972		\$23,500	\$53,339,165
Transfers In														
General Fund Transfer		\$1,400,121	\$361,000	\$613,002			\$100,000		\$10,000		\$70,000			\$2,554,123
Surface Water Fund Transfer	\$426,837													\$426,837
Street Fund Transfer	\$530,176													\$530,176
Development Services Fund Transfer														
General Capital Fund Transfer	\$33,754													\$33,754
Roads Capital Fund Transfer	\$55,680													\$55,680
Surface Water Capital Fund Transfer														
General Reserve Fund Transfer														
Equipment Replacement Fund Transfer														
Total Transfers In	\$1,046,447	\$1,400,121	\$361,000	\$613,002			\$100,000		\$10,000		\$70,000			\$3,600,570
Total Resources	\$35,169,830	\$3,097,330	\$27,163,570	\$13,768,532	\$11,703,421	\$2,341,193	\$1,785,641	\$199,625	\$82,758	\$150,628	\$255,124	\$212,240	\$57,331	\$95,987,223
	\$28,426,980													
	\$6,742,850													
Operating Expenditures														
City Council	\$174,494													\$174,494
City Manager	\$815,352													\$815,352
Economic Development	\$257,725													\$257,725
City Clerk	\$403,027													\$403,027
Community & Govt. Relations	\$578,700													\$578,700
Human Services	\$592,010													\$592,010
City Attorney	\$550,782													\$550,782
Finance	\$3,810,526						\$100,000		\$10,000					\$3,920,526
Human Resources	\$391,553													\$391,553
Customer Response Team	\$454,259													\$454,259
Police	\$8,541,937												\$23,500	\$8,565,437
Criminal Justice	\$1,379,426													\$1,379,426
Parks & Recreation	\$3,953,790													\$3,953,790
Planning & Development Services	\$2,756,866									\$100,000				\$2,856,866
Public Works	\$1,212,411	\$1,891,911			\$1,672,866			\$139,988						\$4,917,176
Operating Expenditures	\$25,872,858	\$1,891,911			\$1,672,866		\$100,000	\$139,988	\$10,000	\$100,000			\$23,500	\$29,811,123
Capital Expenditures			\$23,657,469	\$7,177,754	\$3,849,254						\$110,000			\$34,794,477
Transfers Out														
Roads Capital Transfer	\$613,002													\$613,002
General Reserve Fund Transfer														
Street Fund Transfer	\$1,400,121													\$1,400,121
Public Art Fund Transfer														
Overhead / Indirect Cost Plan		\$530,176	\$33,754	\$55,680	\$426,837									\$1,046,447
Surface Water Enterprise Fund														
General Capital Transfer	\$361,000													\$361,000
Major Maint. Capital Transfer	\$70,000													\$70,000
General Fund Transfer														
Development Services Fund Transfer														
Public Works CRT Share														
Technology Plan Share														
Surface Water Management Fund														
Code Abatement Fund Transfer														
Equipment Replacement Fund Transfer	\$100,000													\$100,000
Unemployment Fund Transfer	\$10,000													\$10,000
Total Transfers Out	\$2,554,123	\$530,176	\$33,754	\$55,680	\$426,837									\$3,600,570
Total Expenditures	\$28,426,981	\$2,422,087	\$23,691,223	\$7,233,434	\$5,948,957		\$100,000	\$139,988	\$10,000	\$100,000	\$110,000		\$23,500	\$68,206,170
Ending Fund Balance	\$6,742,849	\$675,243	\$3,472,347	\$6,535,098	\$5,754,464	\$2,341,193	\$1,685,641	\$59,637	\$72,758	\$50,628	\$145,124	\$212,240	\$33,831	\$27,781,053



This Page Has Been Intentionally Left Blank



CAPITAL IMPROVEMENT PROGRAM

Introduction

The Capital Improvement Plan provides a multi-year list of proposed major capital expenditures and associated operating costs for the City. This plan attempts to set funding strategies not only for the current year, but also to project future needs for major construction, land acquisition and equipment needs that improve the cultural environment, capital infrastructure and recreational opportunities for the citizens of Shoreline. Capital expenditures are viewed not only in the context of how much the new project will cost, but also what impact the project will have on the City's operating budget.

Impacts of Growth Management

Capital facilities planning and financing is now subject to the State of Washington Growth Management Act of 1990 (GMA). The GMA requires communities to adopt comprehensive plans designed to guide the orderly development of growth over the next twenty years.

To comply with GMA, the City prepared a comprehensive Capital Facilities Plan (CFP). The CFP provides long range policy guidance for the development of capital improvements. The purpose of a CFP is to identify and coordinate those capital improvements deemed necessary to accommodate orderly growth, set policy direction for capital improvements and ensure that needed capital facilities are provided in a timely manner.

The GMA requires that the CFP contain the following elements:

1. An inventory of existing public owned capital facilities showing locations and capacities.
2. A forecast of the future needs for such capital facilities.
3. The proposed locations and capacities of expanded or new capital facilities.
4. A minimum six-year plan that will finance such capital facilities within projected funding capacities and clearly identifies sources of public money for such purposes.
5. A requirement to reassess the land-use element if probable funding falls short of meeting existing needs.

Capital facilities are defined as mandatory elements for inclusion in the comprehensive plan.

Capital Planning, Programming and Budget System

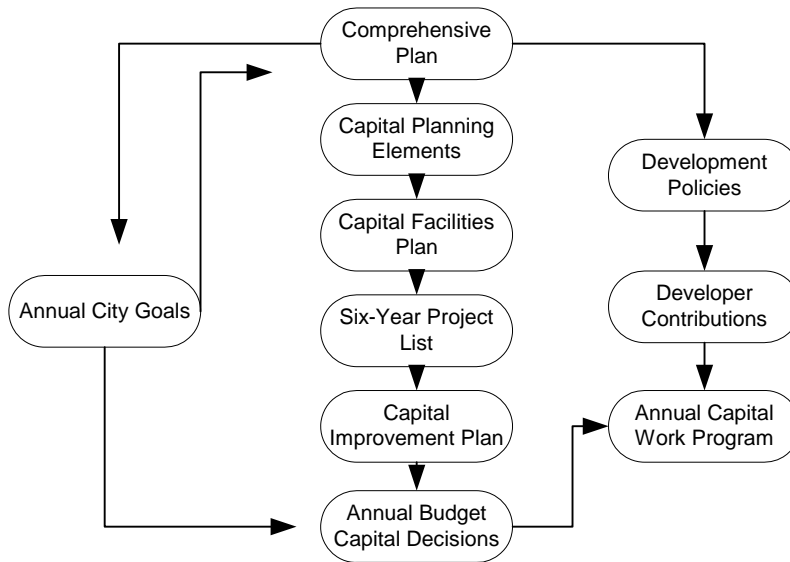

Capital Improvement Fund Descriptions

The City’s Capital Improvement Plan includes three capital funds and the capital portion of the Surface Water Utility Fund. They include:

GENERAL CAPITAL FUND: In the General Capital Fund projects are categorized as Facilities Projects, Parks Projects, Recreation Facilities Projects, and Open Space Projects. Funding for these projects is primarily a result of the allocation of one-time General Fund revenues, real estate excise tax, municipal financing, and grants.

FACILITIES MAJOR MAINTENANCE FUND: In the Facilities Maintenance fund, projects are categorized as either General Facilities or Parks Facilities. Funding for these projects is provided by an annual transfer of \$70,000 from the City’s General Fund.

ROADS CAPITAL FUND: In the Roads Capital fund, projects are categorized as Pedestrian/Non-Motorized Projects, System Preservation Projects, and Safety/Operations Projects. Funding for these projects is provided as a result of allocation from the General Fund, fuel tax, real estate excise tax (REET), and grants

SURFACE WATER UTILITY FUND: In the Surface Water Utility Fund, projects are categorized as either Conveyance and Treatment Projects or Stream Rehabilitation/.Habitat Enhancement Projects. Funding for these projects is provided from an allocation of surface water fees or financing such as Public Works Trust Fund Loans. Any debt, which is used to finance projects, must be repaid by allocating a portion of surface water fees for this purpose.

Capital Budget Criteria

Capital improvement programming and budgeting involves the development of a long-term plan for capital expenditures for the City of Shoreline. Capital expenditures include expenditures for buildings, land, major equipment, and other commodities which are of significant value (greater than \$10,000) and have a useful life of at least five years.

The capital improvement plan (CIP) lists each proposed capital item to be undertaken, the year in which it will be started, the amount expected to be expended in each year and the proposed method of financing these expenditures. Based on these details, summaries of capital activity in each year can be prepared as well as summaries of financial requirements such as amounts of general obligation bonds to be issued, amounts of general operation funds required and any anticipated intergovernmental support, etc.

The capital improvement budget is enacted annually based on the capital improvement plan. It encompasses enacting appropriations for the projects in the first year of the capital improvement plan.

Flexibility is built into the capital improvement plan to allow for delay of projects when financing constraints make it impossible to allow for funding of the entire array of projects and to move future projects forward when financial availability makes it possible. The point is that the CIP is required to be updated at a minimum annually to:

- Make any adjustments in future program years when changes occur in funding or cost.
- Add a year of programming to replace the current year funded.

Advantages of Capital Planning

In addition to the Growth Management Act (GMA) which requires communities to establish a long-range capital plan, there are several advantages to the community from capital planning.

- Capital planning facilitates repair or replacement of existing facilities before they fail. Failure is almost always costly, time consuming and more disruptive than planned repair or replacement.
- It focuses the community and City Council's attention to priority goals, needs and capabilities. There are always more needs and competing projects than the available funds. A good capital plan forces the City to consciously set priorities between competing projects and interests. New projects and good ideas can then be ranked against the established project priority array.

- A CIP provides a framework for decisions about community growth and development. Long-range planning for infrastructure needs allows the community to accommodate reasonable growth without being overwhelmed.
- A CIP promotes a more efficient government operation. Coordination of capital projects can reduce scheduling problems and conflicts between several projects. Related projects such as sidewalks, drainage and roads can be planned simultaneously.
- A CIP enhances opportunities for outside financial assistance. Adequate lead-time allows for all avenues of outside grant funding of government agency assistance to be explored.
- A CIP serves as an effective community education tool, that conveys to the public that the City Council has made decisions that affect the future of the City and is guiding the development of the community.

Capital project activity is funded with cash made available by the issuance of General Obligation debt, by grants, by general tax allocation, and by transfers from other funds as may be approved by the City Council.

Annual contributions may be used in whole or in part to fund capital projects as cash assets are accumulated, or the annual contributions may be allowed to remain in reserve until funds, along with accrued interest have grown sufficiently to permit larger projects to be undertaken and paid for with cash.

Capital Improvement Program Plan Policies

A number of important policy considerations are the basis for the Capital Improvement Program (CIP) Plan. These policies provide guidelines for all financial aspects of the CIP, and ultimately affect the project selection process.

A. Relationship of Long-Range Plans to the CIP

The CIP will be updated annually as part of the City's budget process. The City Council may amend the CIP Plan at any time as required.

Virtually all of the projects included in the CIP are based upon formal long-range plans that have been adopted by the City Council. This ensures that the City's Capital Improvement Program, which is the embodiment of the recommendations of these individual planning studies, is responsive to the officially stated direction of the City Council as contained in the Comprehensive Plan, Council work goals, and supporting documents. Examples of these supporting documents: Pavement Management System Plan and the Parks and Open Space and Recreation Services Plan. There are exceptions, but they are relatively small when compared to the other major areas of expenditure noted above.

B. CIP Coordination Team

A CIP Coordination Team is a cross-departmental team which participates in the review and recommendation of the CIP program to the City Manager. The Team will review proposed capital projects in regards to accurate costing (design, capital, and operating), congruence with City objectives, and prioritize projects by a set of deterministic criteria. The Finance Director, or his/her designee, will serve as the lead for the team.

C. Establishing CIP Priorities

The City uses the following basic CIP project prioritization and selection process:

1. Each CIP program area establishes criteria to be used in the prioritization of specific projects submitted for funding. These specific criteria are developed by staff in conjunction with City Council priorities and input from citizens, associated City boards and commissions. The City has divided its CIP projects into the following program areas: General and Parks Capital Projects, Roads Capital Projects, and Surface Water Capital Projects.
2. Designated personnel within City departments recommend project expenditure plans to the Finance Department. The project expenditure plans include all capital costs and any applicable maintenance and operation expenditures along with a recommended funding source.
3. The CIP Coordination Team evaluates the various CIP projects and selects those with the highest priority based on input from citizens, project stakeholders, appropriate advisory committees, and City Council goals.
4. A Preliminary CIP Plan is developed by the Finance Department and is recommended to the City Council by the City Manager.
5. The City Council reviews the Preliminary CIP Plan, holds a public hearing (s) on the plan, makes their desired alterations, and then officially adopts the CIP and establishes related appropriations as a part of the City's budget.
6. Within the available funding, the highest priority projects are then selected and funded in the CIP.

D. Types of Projects Included in the CIP Plan

The CIP Plan will display, to the maximum extent possible, all major capital projects in which the City is involved. It is difficult to define precisely what characteristics a project should have before it is included in the CIP Plan for the public's and City Council's review and approval. While the following criteria may be used as a general guide to distinguish among projects which should be included or excluded from the CIP Plan, there are always exceptions which require management's judgment. Therefore, the City Manager has the administrative authority to determine which projects should be included in the CIP Plan and which projects are more appropriately contained in the City's operating budget.

For purposes of the CIP Plan, a CIP project is generally defined to be any project that possesses all of the following characteristics:

1. Exceeds an estimated cost of \$10,000;
2. Involves totally new physical construction, reconstruction designed to gradually and systematically replace an existing system on a piecemeal basis, replacement of a major component of an existing facility, or acquisition of land or structures; and
3. Involves City funding in whole or in part, or involves no City funds but is the City's responsibility for implementing, such as a 100% grant-funded project or 100% Local Improvement District funded project.
4. Involves the skills and construction needs beyond those needed for a general repair and maintenance project.

These should be considered general guidelines. Any project in excess of \$25,000 meeting the criteria of (2), (3) and (4) above, or various miscellaneous improvements of a like nature whose cumulative total exceeds \$25,000 (i.e., street overlays) should be considered as part of the CIP process.

Program area managers are responsible for the cost estimates of their proposed programs, including future maintenance and operations costs related to the implementation of completed projects.

E. Scoping and Costing Based on Predesign Study:

For some projects it is difficult to develop accurate project scopes, cost estimates, and schedules on which no preliminary engineering or community contact work has been done. To address this problem, some projects are initially proposed and funded only for preliminary engineering and planning work. This funding will not provide any monies to develop final plans, specifications, and estimates to purchase rights-of-way or to construct the projects. Future project costs are refined through the predesign study process.

F. Required Project Features and Financial Responsibility: If a proposed project will cause a direct impact on other publicly-owned facilities, an equitable shared and funded cost plan must be coordinated between the affected program areas.

G. Predictability of Project Timing, Cost and Scope:

The predictability of timing and costs of projects is important to specific private developments, such as the provision of street improvements or the extension of major sewer lines or water supply, without which development could not occur. These projects generally involve significant financial contributions from such private development through developer extension agreements, LIDs, and other means. Once a project has been approved by the City Council in the CIP, project scheduling is a priority to maintain.

The City Council authorizes the City Manager to administratively approve the acceleration of projects schedules so long as they can be accomplished within

budgeted and any allowable contingency expenditures, with the understanding that all controversial issues will be brought before the City Council. All project additions or deletions must be approved by the City Council.

H. CIP Maintenance and Operating Costs:

CIP projects, as approved by the City Council, shall have a funding plan for maintenance and operating costs identified in the project description. These costs will be included in the City's long-term financial planning.

I. Local Improvement Districts (LID)

Examples of when future LIDs may be formed are as follows: 1) where old agreements exist, committing property owners to LID participation on future projects; 2) when a group of property owners wish to accelerate development of a certain improvement; 3) when a group of property owners desire a higher standard of improvement than the City's project contemplates; or 4) when a group of property owners request City assistance in LID formation to fund internal neighborhood transportation facilities improvements, which may or may not have City funding involved. If City funding is proposed by the project sponsors (property owners), they shall so request of the City Council (through the City Clerk) in writing before any LID promotion activity begins. The City Manager shall analyze such request and report his conclusions and recommendation to Council for their consideration. The Council shall by motion affirm or deny the recommendation. The Council's affirmative motion to financially participate shall expire in 180 days, unless the project sponsors have submitted a sufficient LID petition by that time.

In the event that the request is for street resurfacing in advance of the City's normal street resurfacing cycle, the City's contribution, if any, will be determined based on a recommendation from the Public Work's Department and a financial analysis of the impact of completing the project prior to the City's original timeline.

On capital projects whose financing depends in part on an LID, interim financing will be issued to support the LID's portion of the project budget at the same time or in close proximity to the issuance of the construction contract. The amount of the interim financing shall be the current estimate of the final assessment roll as determined by the administering department.

In the event that the project is 100% LID funded, interim financing shall be issued either in phases (i.e., design phase and construction phase) or up front in the amount of the entire estimated final assessment roll, whichever means is estimated to provide the lowest overall cost to the project as determined by the Finance Department.

The City will recapture direct administrative costs incurred by the City for the LID project by including these in the preliminary and final assessment roles.

- J. Preserve Existing Capital Infrastructure Before Building New Facilities:**
The City's policy to ensure that adequate resources are allocated to preserve the City's existing infrastructure before targeting resources toward building new facilities that also have maintenance obligations. This policy addresses the need to protect the City's historical investment in capital facilities and to avoid embarking on a facility enhancement program which, together with the existing facilities, the City cannot afford to adequately maintain.
- K. New Facilities Should Be of High Quality, Low Maintenance, Least Cost:**
The intent of this policy is to guide the development and execution of the CIP Plan through an emphasis on lowest life-cycle cost. Projects should only be built if the necessary funding to operate them is provided. Also, priority is given to new facilities that have minimal ongoing maintenance costs so as to limit the impact upon both the CIP and the operating budget.
- L. Public Input at All Phases of Projects:**
The City makes a serious commitment to public involvement. The City's long-range plans are developed through an extensive citizen involvement program.
- M. Basis for Project Appropriations:**
During the City Council's CIP Plan review, the City Council will appropriate the full estimated project cost for all projects in the CIP Plan. Subsequent adjustments to appropriation levels for amendments to the CIP Plan may be made by the City Council at any time.
- N. Balanced CIP Plan:**
The CIP Plan is a balanced six-year plan. This means that for the entire six-year period, revenues will be equal to project expenditures in the plan. It is anticipated that the plan will have more expenditures than revenues in single years of the plan, but this imbalance will be corrected through the use of interim financing, if actually needed. Over the life of the six-year plan, however, all planned interim debt will be repaid and all plan expenditures, including interest costs on interim debt will be provided for with identified revenues. Any project funding plan, in which debt is not retired within the current six-year plan, must have specific City Council approval.
- O. Use of Debt in the CIP:**
The CIP is viewed as a long-term program that will continually address capital requirements far into the future. As such, the use of long-term debt should be minimized, allowing the City to put money into actual projects that benefit Shoreline residents and businesses rather than into interest payments to financial institutions. There may be exceptions to this policy for extraordinary circumstances, where voted or non-voted long-term debt must be issued to achieve major City goals that otherwise could not be achieved, or would have to wait an unacceptably long time. Issuance of long-term debt must receive City Council authorization.

Staff monitors CIP cash flow regularly and utilizes fund balances to minimize the amount of borrowing required. Funds borrowed for cash flow purposes are limited to short-term obligations. Projected financing costs are included within a project in the administrative program area.

P. Finance Director's Authority to Borrow:

The Finance Director is authorized to initiate interim and long-term borrowing measures, as they become necessary, as identified in the CIP Plan and approved by the City Council.

Q. CIP Plan Update and Amendment:

The CIP Plan will be updated at least annually. The City Council may amend the CIP Plan at any time if a decision must be made and action must be taken before the next CIP review period. All project additions or deletions must be approved by the City Council.

R. Usage of County-Imposed Vehicle License Fees:

The City's share of the King County-imposed Vehicle License Fees is a component of "Transportation Funding" and can therefore be assumed to be part of the annual Transportation Funding contribution to the CIP Plan as pursuant to State Law.

S. Formalization of Monetary Agreements:

All agreements between the City and outside jurisdictions, where resources are exchanged shall be in writing specifying the financial terms of the agreement, the length of the agreement, and the timing of any required payments (i.e., Joint CIP projects where the City is the lead agency, grant funded projects, etc.). Formalization of these agreements will protect the City's interests. Program areas shall make every effort to promptly request any reimbursements that are due the City. Where revenues from outside jurisdictions are ongoing, these requests shall be made at least quarterly, unless alternative arrangements are approved by the City Manager or City Council.

T. Applicable Project Charges:

CIP projects should reflect all costs that can be clearly shown to be necessary and applicable. Staff charges to CIP projects will be limited to time spent actually working on those projects and shall include an overhead factor to cover the applicable portion of that person's operating cost.

2007-2012 Capital Projects by Category

\$158.9
Million

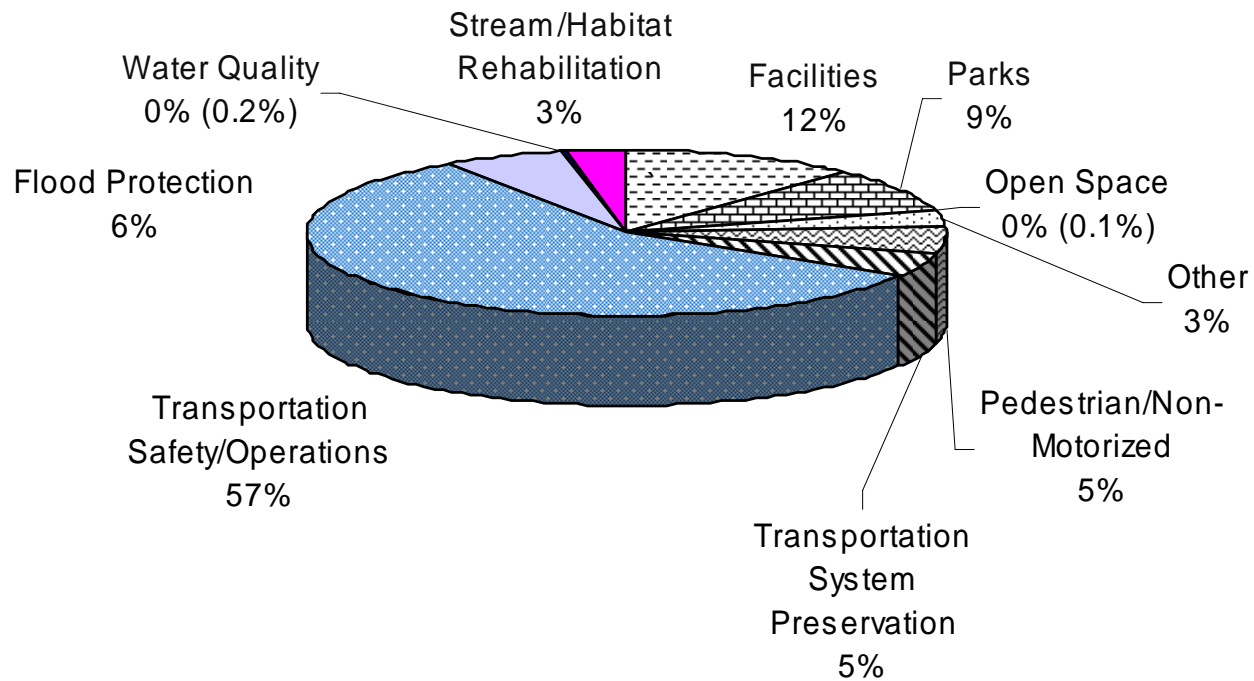

2007-2012 Capital Resources by Category

\$158.9 Million

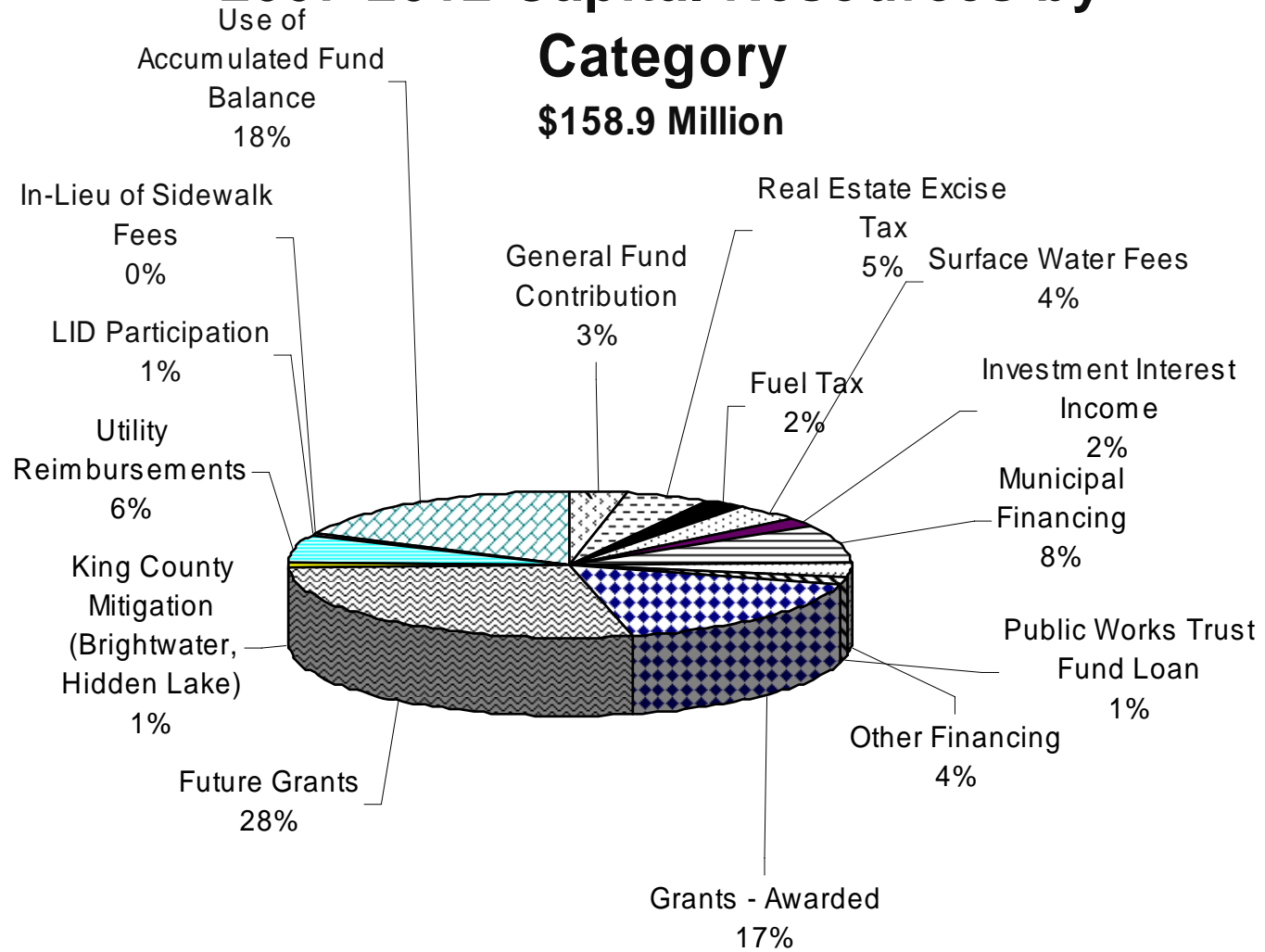

City of Shoreline 2007 - 2012 Capital Improvement Plan PROGRAM SUMMARY

EXPENDITURES Fund	Proposed 2007	Proposed 2008	Proposed 2009	Proposed 2010	Proposed 2011	Proposed 2012	Total 2007-2012
<i>Project</i>							
General Capital							
<i>Facilities Projects</i>							
City Hall	\$18,400,000	\$0	\$0	\$0	\$0	\$0	\$18,400,000
City Gateways/Community Signage	\$25,000	\$0	\$0	\$0	\$0	\$0	\$25,000
City Maintenance Facility	\$34,000	\$0	\$0	\$0	\$0	\$0	\$34,000
<i>Parks Projects</i>							
Richmond Beach Saltwater Park Improvements	\$1,090,000	\$2,150,000	\$0	\$0	\$0	\$0	\$3,240,000
Parks Equipment	\$15,000	\$93,000	\$0	\$0	\$100,000	\$0	\$208,000
Spartan Gym Upgrades	\$85,000	\$0	\$0	\$0	\$0	\$0	\$85,000
Parks Repair & Maintenance	\$205,000	\$231,000	\$242,000	\$252,000	\$263,000	\$273,000	\$1,466,000
Ronald Bog Park Master Plan	\$0	\$0	\$0	\$0	\$0	\$0	\$0
Twin Ponds Master Plan	\$0	\$31,000	\$0	\$0	\$0	\$0	\$31,000
Richmond Beach Area Park Improvements	\$400,000	\$255,187	\$0	\$0	\$0	\$0	\$655,187
Richmond Beach Saltwater Park Bridge Replacement	\$47,000	\$200,000	\$0	\$0	\$0	\$622,000	\$869,000
Cromwell Park	\$127,000	\$1,500,000	\$0	\$0	\$0	\$0	\$1,627,000
Boeing Creek Park Improvements	\$186,000	\$940,000	\$0	\$0	\$0	\$0	\$1,126,000
N. 180th & Midvale Ave. N. Park Development	\$6,000	\$0	\$0	\$0	\$0	\$0	\$6,000
Baseball/Softball Field Improvements	\$125,000	\$125,000	\$0	\$0	\$0	\$0	\$250,000
Hamlin Park Improvements	\$300,000	\$450,000	\$0	\$0	\$0	\$0	\$750,000
Kruckeberg Gardens	\$200,000	\$0	\$0	\$0	\$0	\$0	\$200,000
Off Leash Dog Park	\$140,000	\$0	\$0	\$0	\$0	\$0	\$140,000
Shoreline Center Tennis Court Lights	\$60,000	\$0	\$0	\$0	\$0	\$0	\$60,000
Trail Corridors	\$1,050,000	\$1,050,000	\$375,000	\$0	\$0	\$0	\$2,475,000
Twin Ponds Park Soccer Field Improvements	\$936,000	\$0	\$0	\$0	\$0	\$0	\$936,000
<i>Open Space Projects</i>							
Paramount Open Space	\$158,050	\$0	\$0	\$0	\$0	\$0	\$158,050
<i>Non-Project Specific</i>							
General Capital Engineering	\$68,419	\$72,840	\$74,482	\$102,357	\$107,474	\$112,848	\$538,421
General Fund Cost Allocation Charge	\$39,797	\$39,797	\$39,797	\$39,797	\$39,797	\$39,797	\$238,782
General Capital Fund Total	\$23,697,266	\$7,137,824	\$731,279	\$394,154	\$510,271	\$1,047,645	\$33,518,440

City of Shoreline 2007 - 2012 Capital Improvement Plan PROGRAM SUMMARY

EXPENDITURES Fund	Proposed 2007	Proposed 2008	Proposed 2009	Proposed 2010	Proposed 2011	Proposed 2012	Total 2007-2012
<i>Project</i>							
City Facilities - Major Maintenance							
<i>Facilities Projects</i>							
Police Station Long-Term Maintenance	\$0	\$0	\$0	\$0	\$26,000	\$17,000	\$43,000
<i>Parks Projects</i>							
Pool Long-Term Maintenance	\$110,000	\$0	\$101,000	\$80,000	\$0	\$22,000	\$313,000
Richmond Highlands Community Center Long-Term Maint	\$0	\$70,000	\$0	\$0	\$0	\$49,000	\$119,000
City Facilities - Major Maintenance Fund Total	\$110,000	\$70,000	\$101,000	\$80,000	\$26,000	\$88,000	\$475,000
Roads Capital Fund							
<i>Pedestrian / Non-Motorized Projects</i>							
Interurban Trail Safety & Enhancement	\$50,000	\$0	\$0	\$0	\$0	\$0	\$50,000
Curb Ramp, Gutter & Sidewalk Program	\$114,000	\$120,000	\$125,000	\$131,000	\$136,000	\$142,000	\$768,000
Sidewalks - Priority Routes	\$785,000	\$940,000	\$945,000	\$950,000	\$960,000	\$967,000	\$5,547,000
Traffic Small Works	\$203,000	\$221,000	\$241,000	\$261,000	\$285,000	\$308,000	\$1,519,000
<i>System Preservation Projects</i>							
Annual Road Surface Maintenance Program	\$788,000	\$825,000	\$863,000	\$900,000	\$938,000	\$975,000	\$5,289,000
Richmond Beach Overcrossing 167AOX	\$2,125,000	\$0	\$0	\$0	\$0	\$0	\$2,125,000
Traffic Signal Rehabilitation	\$153,000	\$156,000	\$0	\$0	\$0	\$0	\$309,000
<i>Safety / Operations Projects</i>							
Neighborhood Traffic Safety Program	\$178,000	\$189,000	\$200,000	\$212,000	\$233,000	\$254,000	\$1,266,000
Aurora Avenue North 165th - 205th	\$1,626,000	\$12,878,000	\$22,333,000	\$19,900,000	\$20,022,000	\$205,000	\$76,964,000
Aurora Avenue North 165th - 205th Utility Improvements	\$0	\$5,000,000	\$5,000,000	\$0	\$0	\$0	\$10,000,000
NCBD/15th Avenue Improvements	\$114,356	\$0	\$0	\$0	\$0	\$0	\$114,356
Dayton Avenue North @ North 175th Street Retaining Wall	\$725,000	\$0	\$0	\$0	\$0	\$0	\$725,000
Meridian Avenue North & N. 175th Subarea Study	\$69,000	\$0	\$0	\$0	\$0	\$0	\$69,000
Richmond Beach Road Subarea Study	\$0	\$25,000	\$0	\$0	\$0	\$0	\$25,000
Aurora Avenue @ N. 185th Street Intersection Improvement	\$0	\$0	\$0	\$0	\$0	\$0	\$0
145th Dual Left Turn at Aurora and New Traffic Signal at 149th	\$0	\$0	\$0	\$100,000	\$200,000	\$200,000	\$500,000
Traffic Signal at 170th/15th Ave NE	\$0	\$100,000	\$150,000	\$150,000	\$0	\$0	\$400,000
<i>Non-Project Specific</i>							
Transportation Improvements Formulation & Engineering	\$247,398	\$258,918	\$268,864	\$281,257	\$281,120	\$156,476	\$1,494,033
General Fund Cost Allocation Overhead Charge	\$56,120	\$56,120	\$56,120	\$56,120	\$56,120	\$56,120	\$336,720
Roads Capital Fund Total	\$7,233,874	\$20,769,038	\$30,181,984	\$22,941,377	\$23,111,240	\$3,263,596	\$107,501,109

City of Shoreline 2007 - 2012 Capital Improvement Plan PROGRAM SUMMARY

EXPENDITURES Fund	Proposed 2007	Proposed 2008	Proposed 2009	Proposed 2010	Proposed 2011	Proposed 2012	Total 2007-2012
<i>Project</i>							
Surface Water Capital							
<i>Flood Protection Projects</i>							
Surface Water Small Projects	\$169,000	\$176,000	\$183,000	\$191,000	\$198,000	\$206,000	\$1,123,000
East Boeing Creek Drainage Improvements	\$535,000	\$275,000	\$275,000	\$0	\$0	\$0	\$1,085,000
Hillwood Park Emergency Bypass	\$0	\$0	\$0	\$46,000	\$138,000	\$143,000	\$327,000
Boeing Creek Park Stormwater Project	\$65,000	\$738,000	\$0	\$0	\$0	\$0	\$803,000
Pan Terra Pond & Pump Project	\$97,000	\$1,857,000	\$0	\$0	\$0	\$0	\$1,954,000
Pump Station No. 25	\$158,000	\$0	\$0	\$0	\$0	\$0	\$158,000
Serpentine Place Storm Drainage Improvements	\$0	\$0	\$117,000	\$683,000	\$0	\$0	\$800,000
Ridgecrest Drainage @ 10th Avenue N.E.	\$0	\$156,000	\$274,000	\$286,000	\$0	\$0	\$716,000
Cromwell Park Wetland	\$163,000	\$0	\$0	\$0	\$0	\$0	\$163,000
Cromwell Park Pond	\$278,000	\$0	\$0	\$0	\$0	\$0	\$278,000
Thornton Creek Corridor	\$1,442,000	\$0	\$0	\$0	\$0	\$0	\$1,442,000
18th Avenue Drainage Improvements	\$0	\$225,000	\$0	\$0	\$0	\$0	\$225,000
N. 167th & Whitman Ave. N. Drainage Improvements	\$50,000	\$450,000	\$0	\$0	\$0	\$0	\$500,000
Ronald Bog Park	\$360,000	\$0	\$0	\$0	\$0	\$0	\$360,000
<i>Water Quality Facilities</i>							
Third Avenue Storm Water Treatment Project	\$0	\$0	\$0	\$0	\$0	\$0	\$0
Darnell Park Wetpond	\$30,000	\$78,000	\$0	\$0	\$0	\$0	\$108,000
Ridgecrest Drainage @ 10th Avenue N.E. Wetpond	\$0	\$16,000	\$40,000	\$42,000	\$0	\$0	\$98,000
Cromwell Park Wetpond	\$125,000	\$0	\$0	\$0	\$0	\$0	\$125,000
<i>Stream Rehabilitation/Habitat Enhancement</i>							
Stream Rehabilitation/Habitat Enhancement Program	\$58,000	\$63,000	\$70,000	\$77,000	\$87,000	\$102,000	\$457,000
Boeing Creek Reach 1 - Bank Stabilization	\$0	\$0	\$645,000	\$725,000	\$755,000	\$786,000	\$2,911,000
Boeing Creek Reach 8 - Bank Stabilization	\$0	\$0	\$315,000	\$354,000	\$368,000	\$383,000	\$1,420,000
Green (Shore) Streets Initiative	\$50,000	\$0	\$0	\$0	\$0	\$0	\$50,000
<i>Non-Project Specific</i>							
Surface Water Project Formulation & Engineering	\$269,255	\$282,418	\$295,139	\$308,446	\$322,368	\$324,368	\$1,801,994
General Fund Cost Allocation Overhead Charge	\$82,812	\$82,812	\$82,812	\$82,812	\$82,812	\$82,812	\$496,872
Surface Water Capital Fund Total	\$3,932,067	\$4,399,230	\$2,296,951	\$2,795,258	\$1,951,180	\$2,027,180	\$17,401,866
TOTAL EXPENDITURES	\$34,973,207	\$32,376,092	\$33,311,214	\$26,210,789	\$25,598,691	\$6,426,421	\$158,896,415

City of Shoreline 2007 - 2012 Capital Improvement Plan PROGRAM SUMMARY

EXPENDITURES	Proposed	Proposed	Proposed	Proposed	Proposed	Proposed	Total
Fund	2007	2008	2009	2010	2011	2012	2007-2012
Project							
RESOURCES							
General Fund Contribution	\$736,326	\$898,111	\$902,045	\$905,844	\$909,778	\$913,712	\$5,265,817
Real Estate Excise Tax - 1st Quarter Percent	\$400,000	\$408,000	\$416,160	\$424,483	\$432,973	\$441,632	\$2,523,248
Real Estate Excise Tax - 2nd Quarter Percent	\$825,000	\$841,000	\$832,320	\$848,966	\$865,946	\$883,265	\$5,096,497
Fuel Tax	\$591,312	\$609,848	\$629,091	\$649,071	\$669,820	\$691,373	\$3,840,515
Surface Water Fees	\$940,894	\$989,683	\$1,038,305	\$1,088,671	\$1,140,385	\$1,191,702	\$6,389,640
Investment Interest Income	\$1,308,598	\$786,185	\$346,465	\$84,376	\$207,637	\$70,117	\$2,803,378
<u>Municipal Financing</u>	<u>\$12,750,000</u>	<u>\$0</u>	<u>\$0</u>	<u>\$0</u>	<u>\$0</u>	<u>\$0</u>	\$12,750,000
<u>Other Financing</u>	<u>\$0</u>	<u>\$0</u>	<u>\$0</u>	<u>\$3,237,500</u>	<u>\$2,240,000</u>	<u>\$483,500</u>	\$5,961,000
<u>Public Works Trust Fund Loan</u>	<u>\$2,033,200</u>	<u>\$134,300</u>	<u>\$0</u>	<u>\$0</u>	<u>\$0</u>	<u>\$0</u>	\$2,167,500
Grants - Awarded	\$3,389,000	\$7,779,673	\$15,919,239	\$0	\$0	\$0	\$27,087,912
<u>Future Grants</u>	<u>\$429,025</u>	<u>\$3,580,186</u>	<u>\$2,657,565</u>	<u>\$20,200,000</u>	<u>\$16,877,000</u>	<u>\$200,000</u>	\$43,943,776
King County Mitigation (Brightwater, Hidden Lake)	<u>\$400,000</u>	<u>\$1,377,757</u>	<u>\$0</u>	<u>\$0</u>	<u>\$0</u>	<u>\$0</u>	\$1,777,757
Utility Reimbursements	\$0	\$5,000,000	\$5,000,000	\$0	\$0	\$0	\$10,000,000
LID Participation	\$0	\$0	\$236,250	\$237,500	\$240,000	\$241,750	\$955,500
In-Lieu of Sidewalk Fees	\$20,000	\$20,000	\$20,000	\$20,000	\$20,000	\$20,000	\$120,000
Use of Accumulated Fund Balance	\$11,149,853	\$9,951,350	\$5,313,774	(\$1,485,623)	\$1,995,152	\$1,289,369	\$28,213,875
TOTAL RESOURCES	\$34,973,207	\$32,376,092	\$33,311,214	\$26,210,789	\$25,598,691	\$6,426,421	\$158,896,415



This Page Has Been Intentionally Left Blank



GENERAL CAPITAL

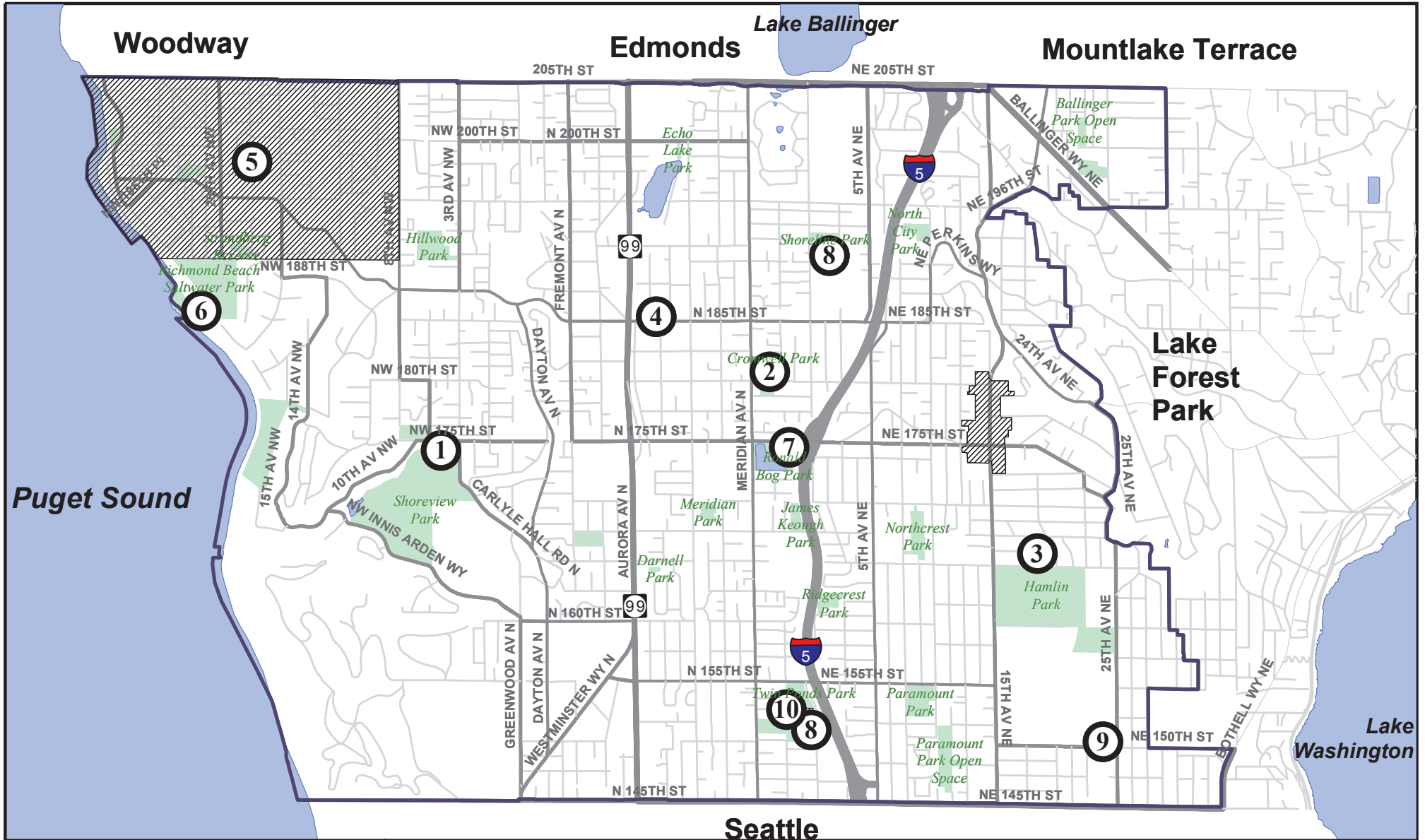



City of Shoreline
2006-2010 General
Capital Improvement Plan



0 500 1,000 2,000 3,000 4,000 Feet

Filename: CIP_General_06.mxd 11:59:05 AM
Plot date: 6/8/2005

-  Project Location
-  Park
-  Richmond Beach Neighborhood

- 1: Boeing Creek Park Improvements
- 2: Cromwell Park
- 3: Hamlin Park Open Space Acquisition
- 4: Police Station Security
- 5: Richmond Beach Area Park Improvements
- 6: Richmond Beach Saltwater Park Pedestrian Bridge Replacement
- 7: Ronald Bog Park Master Plan
- 8: Soccer Field Upgrades
- 9: South Woods
- 10: Twin Ponds Park Master Plan

CITYWIDE IMPROVEMENTS

- City Gateways/Community Signage
- City Hall
- Neighborhood Parks Repair and Replacement
- Parks Equipment

Project	Prior Years' Expenditures	2006 Budget	2006 Projected	2007 Estimate	2008 Estimate	2009 Estimate	2010 Estimate	2011 Estimate	2012 Estimate	Total 2007 - 2012	Total Project Cost
Expenditures											
Facilities Projects											
Civic Center		\$5,006,440	\$6,350,000	\$18,400,000						\$18,400,000	\$24,750,000
City Gateways/Community Signage	\$235,779	\$25,000		\$25,000						\$25,000	\$260,779
Police Station Security		\$15,000	\$15,000								\$15,000
City Maintenance Facility	\$12,750	\$2,250	\$2,000	\$34,000						\$34,000	\$48,750
Civic Center - Future			\$3,300,000								\$3,300,000
Parks Projects											
Richmond Beach Master Plan	\$40,674	\$123,836	\$123,836								\$164,510
Richmond Beach Saltwater Park Improvements				\$1,090,000	\$2,150,000					\$3,240,000	\$3,240,000
Parks Equipment	\$80,000			\$15,000	\$93,000			\$100,000		\$208,000	\$288,000
Spartan Gym Upgrades	\$741,497	\$65,430	\$20,000	\$85,000						\$85,000	\$846,497
Parks Repair and Replacement	\$376,124	\$235,960	\$236,000	\$205,000	\$231,000	\$242,000	\$252,000	\$263,000	\$273,000	\$1,466,000	\$2,078,124
Twin Ponds Park Master Plan					\$31,000					\$31,000	\$31,000
Richmond Beach Area Park Improvements	\$19,813	\$900,000	\$75,000	\$400,000	\$255,187					\$655,187	\$750,000
Saltwater Park Pedestrian Bridge Replacement		\$91,215	\$25,000	\$47,000	\$200,000				\$622,000	\$869,000	\$894,000
Cromwell Park Improvements				\$127,000	\$1,500,000					\$1,627,000	\$1,627,000
Soccer Field Upgrades	\$18,336	\$1,600,000	\$1,695,000								\$1,713,336
Boeing Creek Park Improvements	\$8,177	\$159,823	\$32,000	\$186,000	\$940,000					\$1,126,000	\$1,166,177
N 180th & Midvale Ave N Park Development			\$19,000	\$6,000						\$6,000	\$25,000
Baseball/Softball Field Improvements				\$125,000	\$125,000					\$250,000	\$250,000
Hamlin Park Improvements				\$300,000	\$450,000					\$750,000	\$750,000
Kruckeberg Gardens			\$750,000	\$200,000						\$200,000	\$950,000
Off Leash Dog Park			\$10,000	\$140,000						\$140,000	\$150,000
Shoreline Center Tennis Court Lights				\$60,000						\$60,000	\$60,000
Trail Corridors			\$25,000	\$1,050,000	\$1,050,000	\$375,000				\$2,475,000	\$2,500,000
Twin Ponds Park Soccer Field Improvements			\$25,000	\$936,000						\$936,000	\$961,000
Open Space Projects											
Hamlin Park Open Space Acquisition		\$3,800,000	\$3,750,000								\$3,750,000
South Woods	\$381,850	\$6,000,000	\$6,467,927								\$6,849,777
Paramount Open Space				\$158,050						\$158,050	\$158,050
Non-Project Specific											
General Capital Engineering		\$84,209	\$84,209	\$68,419	\$72,840	\$74,482	\$102,357	\$107,474	\$112,848	\$538,421	\$622,630
General Fund Cost Allocation Charge		\$39,797	\$39,797	\$39,797	\$39,797	\$39,797	\$39,797	\$39,797	\$39,797	\$238,782	\$278,579
Total Expenditures by Year	\$1,915,000	\$ 18,220,960	\$ 23,044,769	\$ 23,697,266	\$ 7,137,824	\$ 731,279	\$ 394,154	\$ 510,271	\$ 1,047,645	\$ 33,518,440	\$ 58,478,209
Revenues											
General Fund Contribution - One-time		\$494,738	\$2,019,738								\$2,019,738
General Fund Contribution - Parks Facilities		\$50,000	\$50,000	\$50,000	\$50,000	\$50,000	\$50,000	\$50,000	\$50,000	\$300,000	\$350,000
Real Estate Excise Tax (1st Quarter)		\$712,674	\$850,000	\$355,000	\$308,000	\$271,160	\$424,483	\$432,973	\$288,632	\$2,080,248	\$2,930,248
Interest Income		\$225,847	\$484,023	\$685,555	\$277,060	\$57,556	\$39,928	\$45,941	\$46,873	\$1,152,913	\$1,636,936
Municipal Financing				\$12,750,000						\$12,750,000	\$12,750,000
Interfund Loan/Other Financing Source		\$800,000	\$3,100,000								\$3,100,000
Bond Issue		\$9,000,000	\$18,500,000								\$18,500,000
<i>IAC Grants</i>				<i>\$300,000</i>	<i>\$700,000</i>					<i>\$1,000,000</i>	<i>\$1,000,000</i>
<i>Conservation Futures Grants</i>		<i>\$1,000,000</i>	<i>\$900,000</i>	<i>\$79,025</i>						<i>\$79,025</i>	<i>\$979,025</i>
Soccer Club Contributions		\$200,000	\$200,000							\$200,000	\$200,000
King County-Brightwater Mitigation		\$700,000	\$75,000	\$400,000	\$255,187					\$655,187	\$730,187
King County-Boeing Creek Park Mitigation					\$541,823					\$541,823	\$541,823
Total Revenues by Year		\$ 13,183,259	\$ 26,178,761	\$ 14,619,580	\$ 2,132,070	\$ 378,716	\$ 514,411	\$ 528,914	\$ 385,505	\$ 18,559,196	\$ 44,737,957
Beginning Fund Balance		\$7,871,969	\$12,100,573	\$15,234,565	\$6,156,879	\$1,151,124	\$798,560	\$918,818	\$937,460	\$15,234,565	
Total Revenues		\$13,183,259	\$26,178,761	\$14,619,580	\$2,132,070	\$378,716	\$514,411	\$528,914	\$385,505	\$18,559,196	
Total Expenditures		\$18,220,960	\$23,044,769	\$23,697,266	\$7,137,824	\$731,279	\$394,154	\$510,271	\$1,047,645	\$33,518,440	
Ending Fund Balance		\$2,834,268	\$15,234,565	\$6,156,879	\$1,151,124	\$798,560	\$918,818	\$937,460	\$275,321	\$275,321	
Impact on Operating Budget	\$0	\$ 20,580	\$ 20,620	\$ 21,218	\$ 14,833	\$ 15,255	\$ 15,083	\$ 12,609	\$ 12,379		



***FACILITIES -
MAJOR
MAINTENANCE***

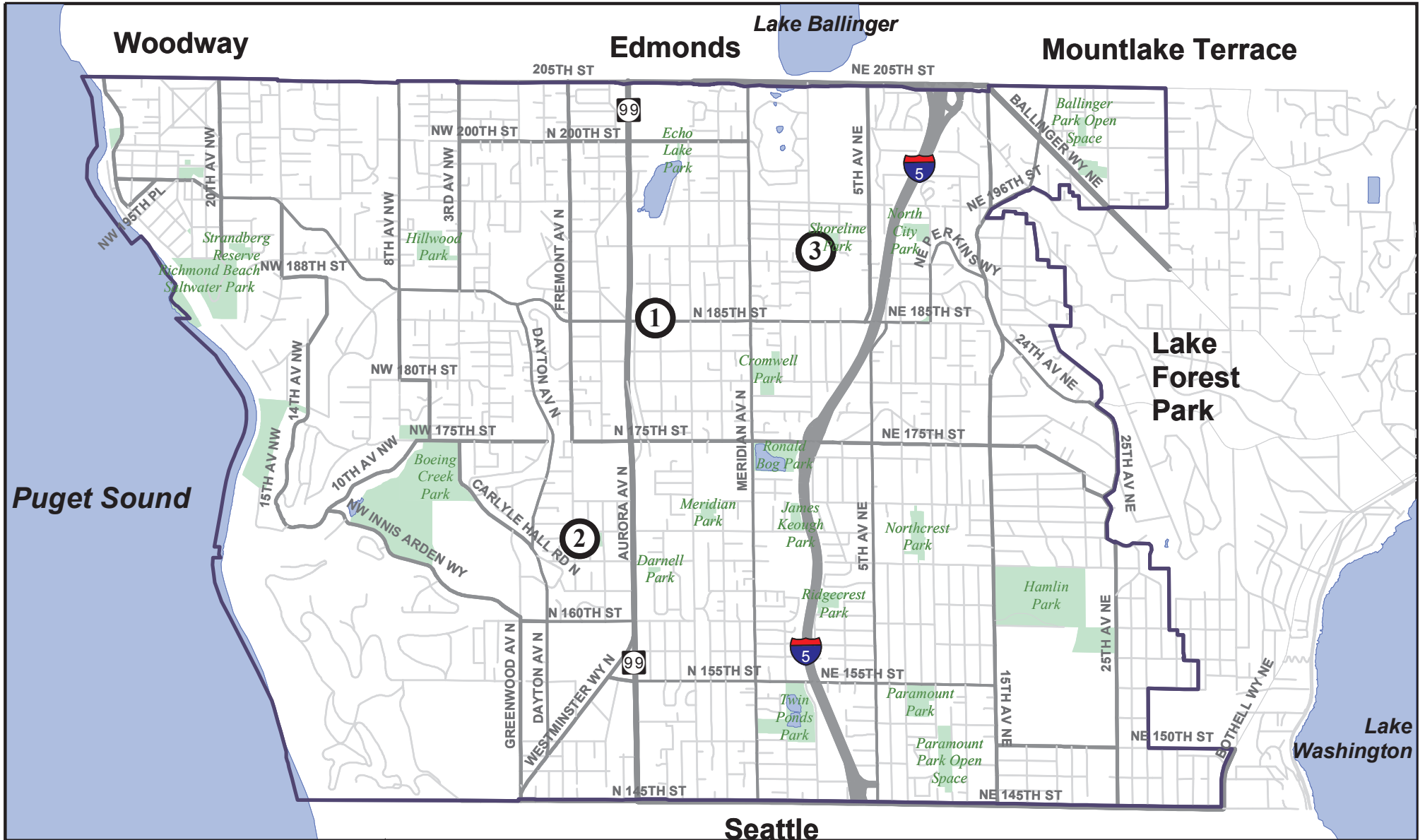



City of Shoreline
2006-2010 Facility
Capital Improvement Plan



0 500 1,000 2,000 3,000 4,000 Feet

Filename: Cip_Facility_06.mxd 11:33:32 AM
Plot date: 6/8/2005

-  Project Location
-  Park

- 1: Police Station
Long-Term Maintenance**
- 2: Richmond Highlands Community Center
Long-Term Maintenance**
- 3: Shoreline Pool
Long-Term Maintenance**

City of Shoreline 2007 - 2012 Capital Improvement Plan											
Program Summary											
City Facility-Major Maintenance Fund											
Project	Prior Years' Expenditures	2006 Budget	2006 Projected	2007 Estimate	2008 Estimate	2009 Estimate	2010 Estimate	2011 Estimate	2012 Estimate	Total 2007-2012	Total Project Cost
Expenditures											
General Facilities											
Police Station Long-Term Maintenance	\$48,944	\$45,000	\$45,000					\$26,000	\$17,000	\$43,000	\$136,944
Parks Facilities											
Pool Long-Term Maintenance	\$34,882			\$110,000		\$101,000	\$80,000		\$22,000	\$313,000	\$347,882
Richmond Highlands Community Center Long-Term Maintenance		\$15,000	\$15,000		\$70,000				\$49,000	\$119,000	\$134,000
Total Expenditures by Year	\$83,826	\$60,000	\$60,000	\$110,000	\$70,000	\$101,000	\$80,000	\$26,000	\$88,000	\$475,000	\$618,826
Revenues											
Operating Transfer - General Fund	\$ 244,000	\$ 70,000	\$ 70,000	\$ 70,000	\$ 70,000	\$ 70,000	\$ 70,000	\$ 70,000	\$ 70,000	\$420,000	\$734,000
Interest Income	\$ 548	\$4,680	\$6,429	\$7,972	\$6,531	\$7,583	\$6,412	\$6,232	\$8,744	\$43,473	\$50,450
Total Revenues by Year	\$ 244,548	\$ 74,680	\$ 76,429	\$ 77,972	\$ 76,531	\$ 77,583	\$ 76,412	\$ 76,232	\$ 78,744	\$ 463,473	\$ 784,450
Beginning Fund Balance		\$156,000	\$160,722	\$177,151	\$145,123	\$151,653	\$128,236	\$124,648	\$174,880	\$177,151	
Total Revenues	\$244,548	\$74,680	\$76,429	\$77,972	\$76,531	\$77,583	\$76,412	\$76,232	\$78,744	\$463,473	
Total Expenditures	\$83,826	\$60,000	\$60,000	\$110,000	\$70,000	\$101,000	\$80,000	\$26,000	\$88,000	\$475,000	
Ending Fund Balance	\$160,722	\$170,680	\$177,151	\$145,123	\$151,653	\$128,236	\$124,648	\$174,880	\$165,624	\$165,624	
Impact on Operating Budget	\$0	\$ (1,000)	\$ 1,000	\$ (1,030)	\$ (11,061)	\$ (11,393)	\$ (13,735)	\$ (14,147)	\$ (14,571)		



ROADS CAPITAL

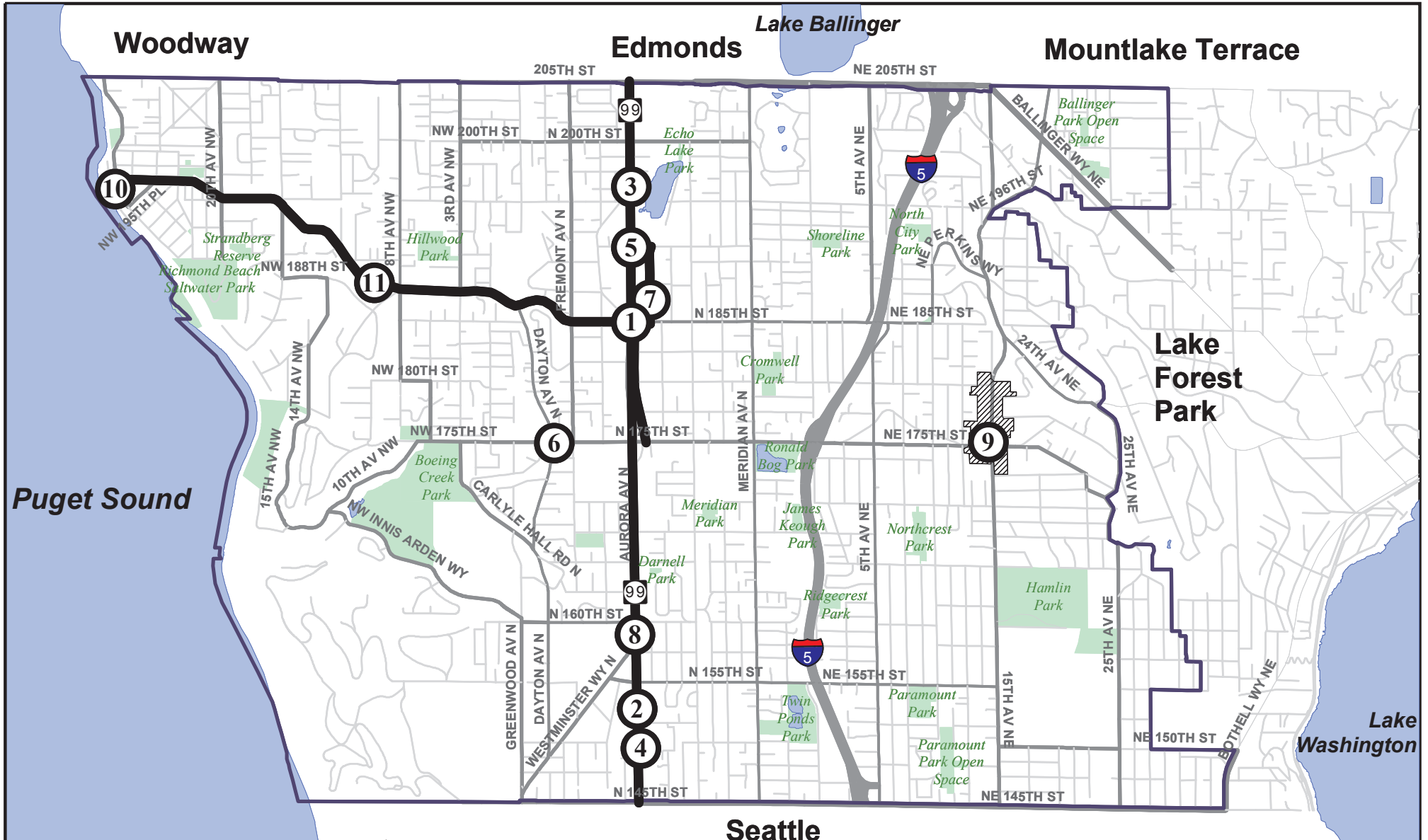

City of Shoreline
2006-2010 Roads
Capital Improvement Plan



0 500 1,000 2,000 3,000 4,000 Feet

Filename: Cip_Roads_06.mxd 11:54:03 AM
Plot date: 6/8/2005



Project Location



Park



North City Business District



Street Improvement Study or Improvement

Seattle

- 1: Aurora Ave N @ 185th St Intersection Imp.
- 2: Aurora Ave N 145th to 165th Utility Improvements
- 3: Aurora Ave N 165th to 205th Utility Improvements
- 4: Aurora Ave N, 145th to 165th
- 5: Aurora Ave N, 165th to 205th
- 6: Dayton Ave N @ N 175th Retaining Wall
- 7: Interurban--North Central Segment
- 8: Interurban Trail Pedestrian Crossing
- 9: North City Business District/15th Imp.
- 10: Richmond Beach Overcrossing 167AOX
- 11: Richmond Beach Rd Sub-area Study

CITYWIDE IMPROVEMENTS

- Annual Road Surface Maintenance Program
- Curb Ramp, Gutter & Sidewalk Program
- Neighborhood Traffic Safety Program
- Sidewalks-Priority Routes
- Traffic Small Works

City of Shoreline 2007 - 2012 Capital Improvement Plan
Program Summary
Roads Capital Fund

Project	Prior Years' Expenditures	2006 Budget	2006 Projected	2007 Estimate	2008 Estimate	2009 Estimate	2010 Estimate	2011 Estimate	2012 Estimate	2007-2012 Total	Total Project
Expenditures											
Pedestrian / Non-Motorized Projects											
Interurban Trail	\$5,298,849	\$10,000	\$10,000								\$5,308,849
Interurban Trail Pedestrian Crossing	\$1,227,824	\$4,709,745	\$5,142,000								\$6,369,824
Interurban Trail - North Central Segment	\$428,875	\$1,788,125	\$2,532,000								\$2,960,875
Interurban Trail Safety & Enhancements				\$50,000						\$50,000	\$50,000
Curb Ramp, Gutter & Sidewalk Program	\$880,100	\$275,042	\$280,000	\$114,000	\$120,000	\$125,000	\$131,000	\$136,000	\$142,000	\$768,000	\$1,928,100
Sidewalks - Priority Routes		\$900,000	\$900,000	\$785,000	\$940,000	\$945,000	\$950,000	\$960,000	\$967,000	\$5,547,000	\$6,447,000
Traffic Small Works	\$47,202	\$317,800	\$318,000	\$203,000	\$221,000	\$241,000	\$261,000	\$285,000	\$308,000	\$1,519,000	\$1,884,202
System Preservation Projects											
Annual Road Surface Maintenance Program	\$4,862,382	\$844,594	\$845,000	\$788,000	\$825,000	\$863,000	\$900,000	\$938,000	\$975,000	\$5,289,000	\$10,996,382
Richmond Beach Overcrossing 167AOX	\$605,537	\$1,992,000	\$505,000	\$2,125,000						\$2,125,000	\$3,235,537
Traffic Signal Rehabilitation		\$150,000	\$150,000	\$153,000	\$156,000					\$309,000	\$459,000
Safety / Operations Projects											
Neighborhood Traffic Safety Program	\$688,091	\$256,059	\$256,000	\$178,000	\$189,000	\$200,000	\$212,000	\$233,000	\$254,000	\$1,266,000	\$2,210,091
Aurora Avenue North 145th - 165th	\$12,451,346	\$14,260,947	\$14,289,000								\$26,740,346
Aurora Avenue North 145-165th Utility Improvements	\$2,687,807	\$3,088,572	\$3,490,000								\$6,177,807
NCBD/15th Avenue Improvements	\$6,969,475	\$2,979,541	\$3,008,000	\$114,356						\$114,356	\$10,091,831
Dayton Avenue North @ North 175th Street Retaining Wall	\$92,533	\$929,651	\$370,000	\$725,000						\$725,000	\$1,187,533
Aurora @ 180th Pedestrian Improvement	\$99,808	\$28,192	\$28,192								\$128,000
Meridian Avenue North & N. 175th Subarea Study		\$150,000	\$81,000	\$69,000						\$69,000	\$150,000
Richmond Beach Road Subarea Study					\$25,000					\$25,000	\$25,000
Aurora @ 185th Street Intersection Improvements	\$11,418	\$501,582	\$30,000								\$41,418
Traffic Calming		\$200,000	\$200,000								\$200,000
145th Dual Left Turn at Aurora and New Traffic Signal at 149th							\$100,000	\$200,000	\$200,000	\$500,000	\$500,000
Traffic Signal at 170th/15th Ave NE					\$100,000	\$150,000	\$150,000			\$400,000	\$400,000
Non-Project Specific											
Transportation Improvements Formulation & Engineering	\$317,997	\$284,642	\$284,284	\$247,398	\$258,918	\$268,864	\$281,257	\$281,120	\$156,476	\$1,494,033	\$2,096,314
General Fund Cost Allocation Overhead Charge		\$56,120	\$56,120	\$56,120	\$56,120	\$56,120	\$56,120	\$56,120	\$56,120	\$336,720	\$392,840
Subtotal Expenditures by Year	\$36,669,244	\$33,722,612	\$32,774,596	\$5,607,874	\$2,891,038	\$2,848,984	\$3,041,377	\$3,089,240	\$3,058,596	\$20,537,109	\$89,980,949
Revenues											
Real Estate Excise Tax (1st Quarter)			\$25,000	\$45,000	\$100,000	\$145,000			\$153,000	\$443,000	\$468,000
Real Estate Excise Tax (2nd Quarter)		\$712,674	\$1,075,000	\$825,000	\$841,000	\$832,320	\$848,966	\$865,946	\$883,265	\$5,096,497	\$6,171,497
General Fund Support (Sidewalks & Gambling Tax Equivalent)		\$1,870,817	\$1,368,725	\$616,326	\$778,111	\$782,045	\$785,844	\$789,778	\$793,712	\$4,545,817	\$5,914,542
Fuel Tax		\$360,425	\$360,425	\$374,986		\$382,486	\$390,136	\$397,938	\$405,897	\$2,319,077	\$2,679,502
Investment Interest		\$300,233	\$523,658	\$350,191	\$296,638	\$215,819	\$38,037	\$155,464	\$2,402	\$1,058,550	\$1,582,208
SWM Fees Used for Drainage work on Transportation Projects		\$202,545	\$22,545	\$157,000	\$188,000	\$189,000	\$2,273,000	\$192,000		\$2,999,000	\$3,021,545
Additional 1/2 Cent Fuel Tax		\$167,759	\$167,759	\$223,678	\$234,862	\$246,605	\$258,935	\$271,882	\$285,476	\$1,521,438	\$1,689,197
In-Lieu of Sidewalk Fees			\$83,615	\$20,000	\$20,000	\$20,000	\$20,000	\$20,000	\$20,000	\$120,000	\$203,615
Awarded Grants		\$19,812,989	\$20,043,341	\$2,105,000						\$2,105,000	\$22,148,341
Anticipated Future Grants		\$300,000	\$135,200	\$50,000	\$150,000	\$200,000	\$300,000	\$250,000	\$200,000	\$1,150,000	\$1,285,200
Utility Reimbursements		\$3,310,913	\$3,641,822								\$3,641,822
<u>Private Developer Contribution</u>		<u>\$200,000</u>	<u>\$100,556</u>								<u>\$100,556</u>
<u>LID Participation</u>						<u>\$236,250</u>	<u>\$237,500</u>	<u>\$240,000</u>	<u>\$241,750</u>	<u>\$955,500</u>	<u>\$955,500</u>
<u>Other Financing</u>							<u>\$237,500</u>	<u>\$240,000</u>	<u>\$483,500</u>	<u>\$961,000</u>	<u>\$961,000</u>
Subtotal Revenues by Year		\$27,238,354	\$27,547,646	\$4,759,828	\$2,983,598	\$3,249,526	\$5,389,917	\$3,423,008	\$3,469,003	\$23,274,879	\$50,822,525
Aurora Avenue North 165th-205th	\$365,681	\$643,072	\$611,000	\$1,626,000	\$12,878,000	\$22,333,000	\$19,900,000	\$20,022,000	\$205,000	\$76,964,000	\$77,940,681
Aurora Avenue North 165th - 205th Utility Improvements					\$5,000,000	\$5,000,000				\$10,000,000	\$10,000,000
Total Roads Capital Expenditures	\$37,034,925	\$34,365,684	\$33,385,596	\$7,233,874	\$20,769,038	\$30,181,984	\$22,941,377	\$23,111,240	\$3,263,596	\$107,501,109	\$177,921,630
Aurora Avenue North 165th - 205th Awarded Grants	\$224,152	\$643,073	\$528,515	\$1,284,000	\$7,779,673	\$15,919,239	\$19,900,000	\$16,627,000		\$24,982,912	\$25,735,579
Aurora Avenue North 165th - 205 Future Grants					\$2,730,186	\$2,457,565				\$41,714,751	\$41,714,751
Aurora Avenue North 165th - 205th Utility Reimbursements					\$5,000,000	\$5,000,000				\$10,000,000	\$10,000,000
Total Roads Capital Revenues	\$224,152	\$27,881,427	\$28,076,161	\$6,043,828	\$18,493,457	\$26,626,330	\$25,289,917	\$20,050,008	\$3,469,003	\$99,972,542	\$128,272,855
Beginning Fund Balance		\$10,007,750	\$13,091,447	\$7,782,012	\$6,591,966	\$4,316,385	\$760,730	\$3,109,271	\$48,039	\$7,782,012	
Total Revenues		\$27,881,427	\$28,076,161	\$6,043,828	\$18,493,457	\$26,626,330	\$25,289,917	\$20,050,008	\$3,469,003	\$99,972,542	
Total Expenditures		\$34,365,684	\$33,385,596	\$7,233,874	\$20,769,038	\$30,181,984	\$22,941,377	\$23,111,240	\$3,263,596	\$107,501,109	
Ending Fund Balance		\$3,523,493	\$7,782,012	\$6,591,966	\$4,316,385	\$760,730	\$3,109,271	\$48,039	\$253,445		
Impact on Operating Budget		\$35,299	\$30,151	\$173,149	\$179,093	\$477,897	\$191,427	\$196,864	\$300,666		
Unfunded Projects											
Traffic Calming				\$210,000	\$220,000	\$230,000	\$240,000	\$250,000	\$260,000	\$1,410,000	\$1,410,000
Traffic Signal Rehabilitation						\$160,000	\$165,000	\$169,000	\$174,000	\$668,000	\$668,000
Aurora @ 185th Street Intersection Improvements			\$455,000	\$682,000						\$682,000	\$1,137,000
Total Unfunded Expenditures by Year			\$455,000	\$892,000	\$220,000	\$390,000	\$405,000	\$419,000	\$434,000	\$2,760,000	\$3,215,000



SURFACE WATER CAPITAL

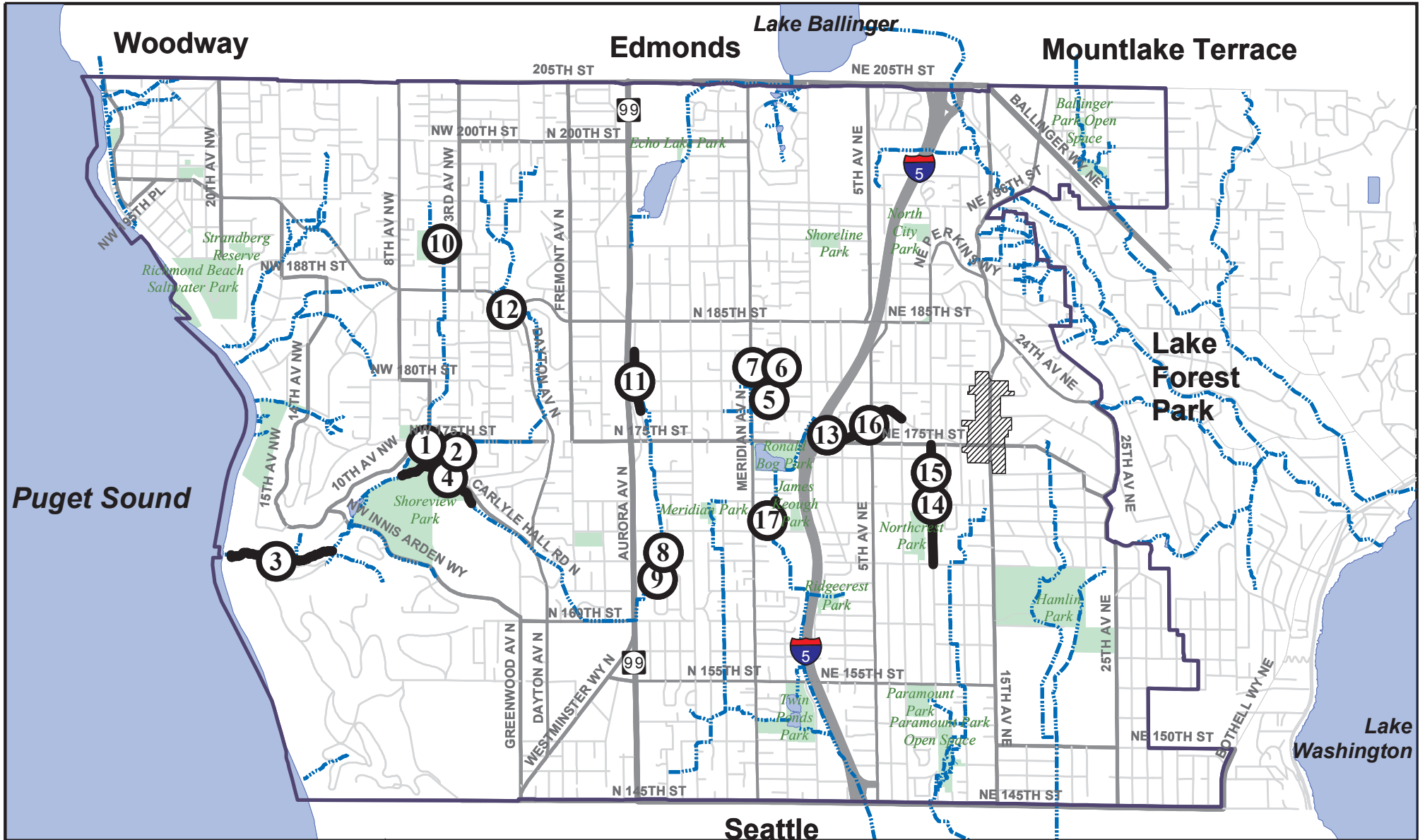

City of Shoreline
2006-2010 Surface Water
Capital Improvement Plan



Filename: Cip_SurfaceWater_06.mxd 10:14:12 AM
Plot date: 6/8/2005



Project Location



Park



North City Business District

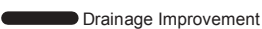

Drainage Improvement



Water Course

- | | |
|--|--|
| 1: 3rd Ave NW Oil-Water Separator | 10: Hillwood Park Emergency Bypass |
| 2: Boeing Creek Park Stormwater Project | 11: Midvale Ave Drainage |
| 3: Boeing Creek Reach 1-Bank Stabilization | 12: Pan Terra Pond & Pump |
| 4: Boeing Creek Reach 8-Bank Stabilization | 13: Pump Station 25 |
| 5: Cromwell Park Pond | 14: Ridgecrest Drainage @ 10th Ave NE |
| 6: Cromwell Park Wetland | 15: Ridgecrest Drainage at 10th Ave NE Wetpond |
| 7: Cromwell Park Wetpond | 16: Serpentine PI Storm Drainage Improvements |
| 8: Darnell Park Neighborhood Drainage | 17: Thornton Creek Corridor |
| 9: Darnell Park Wetpond | |

CITYWIDE IMPROVEMENTS

- Advanced Stormwater Right-of-Way Acquisition
- Stream Rehab / Habitat Enhancement Program
- Surface Water Small Projects

**City of Shoreline 2007 - 2012 Capital Improvement Plan
Program Summary
Surface Water Capital Fund**

Creek Basin	Project	Prior Years' Expenditures	2006 Budget	2006 Projected	2007 Estimate	2008 Estimate	2009 Estimate	2010 Estimate	2011 Estimate	2012 Estimate	Total 2007-2012	Total Project Cost
	Expenditures											
	Flood Protection Projects											
Multiple	Surface Water Small Projects	\$1,122,441	\$223,074	\$180,000	\$169,000	\$176,000	\$183,000	\$191,000	\$198,000	\$206,000	\$1,123,000	\$2,425,441
Boeing	East Boeing Creek Drainage Improvements				\$535,000	\$275,000	\$275,000				\$1,085,000	\$1,085,000
Boeing	Hillwood Park Emergency Bypass							\$46,000	\$138,000	\$143,000	\$327,000	\$327,000
Boeing	Boeing Creek Park Stormwater Project	\$56,653	\$115,348	\$25,000	\$65,000	\$738,000					\$803,000	\$884,653
Boeing	Pan Terra Pond & Pump Project	\$22,696	\$48,304	\$30,000	\$97,000	\$1,857,000					\$1,954,000	\$2,006,696
Thornton	Pump Station No. 25		\$44,000	\$24,000	\$158,000						\$158,000	\$182,000
Thornton	Serpentine Place Storm Drainage Improvements						\$117,000	\$683,000			\$800,000	\$800,000
Thornton	Ridgecrest Drainage @ 10th Avenue. N.E.					\$156,000	\$274,000	\$286,000			\$716,000	\$716,000
Thornton	Cromwell Park Wetland		\$68,000	\$68,000	\$163,000						\$163,000	\$231,000
Thornton	Cromwell Park Pond				\$278,000						\$278,000	\$278,000
Thornton	Thornton Creek Corridor		\$447,000	\$447,000	\$1,442,000						\$1,442,000	\$1,889,000
Puget Snd	18th Avenue Drainage Improvements					\$225,000					\$225,000	\$225,000
Boeing	N. 167th & Whitman Avenue N. Drainage Impvs.				\$50,000	\$450,000					\$500,000	\$500,000
Thornton	Ronald Bog Park Wetland				\$360,000						\$360,000	\$360,000
	Water Quality Facilities											
Boeing	Third Avenue Storm Water Treatment Project		\$100,000	\$50,000								\$50,000
Boeing	Darnell Park Wetpond				\$30,000	\$78,000					\$108,000	\$108,000
Thornton	Ridgecrest Drainage at 10th Avenue N.E. Wetpond					\$16,000	\$40,000	\$42,000			\$98,000	\$98,000
Thornton	Cromwell Park Wetpond				\$125,000						\$125,000	\$125,000
	Stream Rehabilitation / Habitat Enhancement											
Multiple	Stream Rehab / Habitat Enhancement Program	\$58,214	\$82,786	\$83,000	\$58,000	\$63,000	\$70,000	\$77,000	\$87,000	\$102,000	\$457,000	\$598,214
Boeing	Boeing Creek Reach 1 - Bank Stabilization						\$645,000	\$725,000	\$755,000	\$786,000	\$2,911,000	\$2,911,000
Boeing	Boeing Creek Reach 8 - Bank Stabilization						\$315,000	\$354,000	\$368,000	\$383,000	\$1,420,000	\$1,420,000
Multiple	Green (Shore) Streets Initiative				\$50,000						\$50,000	\$50,000
	Non-Project Specific											
	SWM CIP Project Formulation & Engineering	\$158,695	\$244,904	\$244,624	\$269,255	\$282,418	\$295,139	\$308,446	\$322,368	\$324,368	\$1,801,994	\$2,205,313
	General Fund Cost Allocation Overhead Charge		\$82,812	\$82,812	\$82,812	\$82,812	\$82,812	\$82,812	\$82,812	\$82,812	\$496,872	\$579,684
	Total Expenditures by Year	\$1,418,699	\$1,456,228	\$1,234,436	\$3,932,067	\$4,399,230	\$2,296,951	\$2,795,258	\$1,951,180	\$2,027,180	\$17,401,866	\$20,055,001
	Revenues											
	Transfer from Surface Water Fund (Fund Balance)		\$ 3,159,881	\$ 3,159,881								\$3,159,881
	Surface Water Fees		\$ 759,881	\$ 759,881	\$ 940,894	\$ 989,683	\$ 1,038,305	\$ 1,088,671	\$ 1,140,385	\$ 1,191,702	\$6,389,640	\$7,149,521
	<u>Other Financing Sources</u>				\$ -	\$ -	\$ -	\$ 3,000,000	\$ 2,000,000	\$ -	\$5,000,000	\$5,000,000
	Interest Income		\$ 151,786	\$ 106,275	\$ 264,880	\$ 205,956	\$ 65,507	\$ -	\$ -	\$ 12,098	\$548,441	\$654,716
	SWM Improvements in Conjunction w/Transportation Projects		\$ (134,000)	\$ (616,326)	\$ (778,111)	\$ (778,111)	\$ (782,045)	\$ (785,844)	\$ (789,778)	\$ (793,712)	-\$4,545,817	-\$4,545,817
	Public Works Trust Fund Loan		\$ 437,750	\$ 2,033,200	\$ 134,300						\$2,167,500	\$2,605,250
	Boeing Creek - King County/Mitigation		\$ 4,348		\$ 580,747						\$580,747	\$580,747
	Total Revenues by Year		\$ 3,941,896	\$ 4,463,787	\$ 2,622,648	\$ 1,132,575	\$ 321,767	\$ 3,302,827	\$ 2,350,607	\$ 410,088	\$ 10,140,511	\$ 14,604,298
	Beginning Fund Balance		\$2,543,666	\$2,656,869	\$5,886,220	\$4,576,801	\$1,310,146	(\$665,039)	(\$157,470)	\$241,957	\$5,886,220	
	Total Revenues		\$3,941,896	\$4,463,787	\$2,622,648	\$1,132,575	\$321,767	\$3,302,827	\$2,350,607	\$410,088	\$10,140,511	
	Total Expenditures		\$1,456,228	\$1,234,436	\$3,932,067	\$4,399,230	\$2,296,951	\$2,795,258	\$1,951,180	\$2,027,180	\$17,401,866	
	Ending Fund Balance		\$5,029,334	\$5,886,220	\$4,576,801	\$1,310,146	(\$665,039)	(\$157,470)	\$241,957	(\$1,375,135)	(\$1,375,135)	
	Impact on Operating Budget	\$0	\$ 9,030	\$ 8,000	\$ 13,000	\$ 13,300	\$ 13,609	\$ 13,927	\$ 14,255	\$ 14,593	\$ -	\$ 89,121



APPENDIX

Financial Policies

I. [Financial Planning Policies](#)

II. [General Budget Policies](#)

- A. No Operating Deficit
- B. Resources Greater than Estimates
- C. Budget Adoption Level
- D. Necessary to Implement City Council Goals Identified in Annual Workplan
- E. Public Safety Protection
- F. Degradation of Current Service Levels
- G. Investments that are Primarily funded by Additional Fees or Grants
- H. Investments that delay Future Cost Increases
- I. Investments that Forestall Adding Permanent Staff
- J. Commitments that can Reasonably be Maintained over the Long Term
- K. Overhead and Full Cost Allocation
- L. Maintenance of Quality Service Programs
- M. Distinguished Budget Presentation

III. [Formulation and Approval of Budgets](#)

IV. [Budget Adjustment and Amendment Process](#)

- A. Adjustment
- B. Amendment

V. [Reserve and Contingency Fund Policies](#)

- A. Contingency Reserve
- B. Unreserved Fund Balance
- C. Budgeted Operating Contingency
- D. Budgeted Insurance Reserve
- E. Budgeted Capital Improvement Contingency.

VI. [Capital Improvement Program Plan Policies](#)

- A. Relationship of Long-Range Plans to the CIP
- B. Capital Improvement Plan Coordination Team
- C. Establishing CIP Priorities
- D. Types of Projects Included in the CIP
- E. Scoping and Costing Based on Predesign Study
- F. Required Project Features and Financial Responsibility
- G. Predictability of Project Timing, Cost and Scope
- H. CIP Maintenance and Operating Costs
- I. Local Improvement Districts (LID)
- J. Preserve Existing Capital Infrastructure Before Building New Facilities
- K. New Facilities Should be of High Quality, Low Maintenance, Least Cost
- L. Public Input at All Phases of Projects
- M. Basis for Project Appropriations
- N. Balanced CIP Plan
- O. Use of Debt in the CIP
- P. Finance Director's Authority to Borrow
- Q. CIP Plan Update and Amendment
- R. Formalization of Monetary Agreements
- S. Applicable Project Charges

VII. [Debt Policy](#)

I. FINANCIAL PLANNING POLICY

The City shall develop and maintain a 6-year financial forecast that estimates resource and expenditure behavior for the five years beyond the current budget period. This forecast will provide the City's decision makers with an indication of the long-term fiscal impact of current policy and budget decisions. This planning tool must recognize the effects of economic cycles on the demand for services and the City's resources. To this end, the forecast should differentiate between revenue associated with one-time economic activities and revenues derived as a result of base economic growth. City financial planning should ensure the delivery of needed services (many of which become more critical during economic downturns) by assuring adequate reliance on ongoing resources in order to support continued City services during economic downturns.

II. GENERAL BUDGET POLICIES

These general budget policies are the basis on which staff develops budget recommendations and establishes funding priorities within the limited revenues the City has available to provide municipal services.

- A. No Operating Deficit: Current revenues will be sufficient to support current expenditures. Revenue estimates will be realistic and debt financing will not be used for current operating expenses.
- B. Resources Greater than Budget Estimates: Resources (fund balance) greater than budget estimates in any fund shall be considered "one-time" resources and shall not be used to fund ongoing service delivery programs.
- C. Budget Adoption Level: Budget adoption by the City Council shall be at fund level. Any changes in appropriations at fund level require City Council approval.
- D. Necessary to Implement City Council Goals Identified in Annual Workplan: The City Council identifies specific goals as part of its work-plan, and departmental budgets should include adequate resources to accomplish those goals in the expected timeframes.
- E. Public Safety Protection: Public safety is a top priority, and as such, unmet needs in this area should have a priority over other service areas.
- F. Degradation of Current Service Levels: When increased service demands are experienced over a sustained period of time, resources should be provided to prevent service level degradation below an acceptable level.
- G. Investments that are Primarily Funded by Additional Fees or Grants: Programs and investments that are funded through a dedicated revenue source (i.e., non-tax revenue), that meet the goals of the City Council, will receive priority consideration.
- H. Investments that Delay Future Cost Increases: When practical, resources should be allocated for selective preventative investments that can be made to avoid even larger costs in the future.
- I. Investments that Forestall Adding Permanent Staff: Recognizing that personnel related expenditures represent the largest portion of the City's budget, methods to increase efficiency and effectiveness of the delivery of City services through technology improvements should receive priority funding if it can forestall the addition of permanent staff.
- J. Commitments that can Reasonably be Maintained over the Long-Term: Funding for new programs and services in operating funds should be limited to the extent that they can be reasonably funded over the near-to-long-term given the current revenue stream.
- K. Overhead and Full Cost Allocation: Department budgets should be prepared in a manner to reflect the full cost of providing services.
- L. Maintenance of Quality Service Programs: The City of Shoreline will offer quality service programs. If expenditure reductions are necessary as a result of changing economic status, selective service elimination is preferable to poor or marginal quality programs that are caused by across the board cuts.

- M. Distinguished Budget Presentation: The City will seek to comply with the suggested criteria of the Government Finance Officers Association in producing a budget document that meets the Distinguished Budget Presentation program criteria as policy document, as an operations guide, as a financial plan, and as a communication device.

III. FORMULATION AND APPROVAL OF BUDGETS

In accordance with RCW 35A.33, departments shall be requested by the Finance Director to prepare detailed estimates of revenues and expenditures for the next fiscal year by no later than the second Monday of September. Responses will be due by no later than the fourth Monday in September, and by no later than the first business day in October, the Finance Director will present to the City Manager a proposed preliminary budget setting forth the complete financial program, showing expenditures requested by each department and sources of revenue by which each program is proposed to be financed.

Although the schedule outlined above meets the requirements of the Revised Code of Washington, the Shoreline budget process usually follows an accelerated time schedule. The Finance Director typically requests departments to prepare their detailed estimates of revenues and expenditures for the next fiscal year in July, with those responses due in August.

By no later than the first Monday in October, the City Manager will provide the City Council with current information on estimates of revenues from all sources as adopted in the budget for the current year. The City complies with this requirement by providing the City Council with a quarterly report and a comprehensive overview of the City's current financial position at a summer Budget Retreat.

The administration will analyze program priorities and needs and recommend funding levels for each program in a proposed operating budget and six-year capital improvement program, which will be submitted to the Council by no later than 60 days prior to the end of the fiscal year. The City Manager typically presents the proposed budget to the City Council in late October.

As part of the budget document, a budget message will be prepared that contains the following:

- An explanation of the budget document.
- An outline of the recommended financial policies and programs of the City for the ensuing fiscal year.
- A statement of the relation of the recommended appropriation to such policies and programs.
- A statement of the reason for salient changes from the previous year in appropriation and revenue items.
- An explanation of any recommended major changes in financial policy.

The operating budget proposal for the general fund will include a financial plan that shows projected revenues and expenditures for at least the next five fiscal years. The financial plan will provide an explanation of the assumptions used in projecting future year expenditure and revenue levels, such as growth in tax revenues, inflation, cost of services, and other factors that may impact the financial condition of the City.

The operating budget will be classified and segregated according to a standard classification of accounts as prescribed by the State Auditor.

The Council will hold public hearings as required and approve operating and capital budgets prior to the end of the fiscal year in accordance with State law.

IV. BUDGET ADJUSTMENT & AMENDMENT PROCESSES

Under the provisions of State law and the City's operating procedures, the operating budget may be adjusted or amended in two different ways. Adjustment of the budget involves a reallocation of existing appropriations and does not change the budget "bottom line."

Amendment of the budget involves an addition to or reduction of existing appropriations.

A. Adjustment

The City departmental expenditures and program goals are monitored throughout the year. Certain departments may develop the need for additional expenditure authority to cover unanticipated costs that cannot be absorbed within the budget, while other departments may unexpectedly not require their full budget authorizations. The Finance Department reviews and analyzes all department and/or fund budgets to determine what adjustments are necessary and whether the adjustments can be made within existing appropriation limits and within the City Council and Departmental goals as provided in the budget. Necessary adjustments are then reviewed with the affected department and/or fund managers. When an adjustment is needed, the Finance staff will look first to savings within the department and then consider budget transfers between departments. The Finance Director, in conjunction with the Department Directors and the City Manager, reviews and decides if any specific budget reductions are needed. No City Council action is needed as State law allows budget adjustments to be done administratively and approved by the City Manager. As a matter of practice, staff will include any adjustments made between departments with the quarterly financial information provided to the City Council.

B. Amendment

Amending the City's budget occurs whenever the requested changes from departments and/or funds will cause the existing appropriation level for the fund to change. This situation generally occurs when the City Council authorizes additional appropriation. This is done by an ordinance that amends the original budget and states the sources of funding for the incremental appropriations.

V. RESERVE AND CONTINGENCY FUND POLICIES

A. Contingency Reserve

It is the City's policy to maintain a contingency reserve in accordance with RCW 35A.33.040. The reserve will be available for unforeseen urgent or emergency needs. The contingency reserve is intended to provide for unanticipated expenditures or revenue shortfalls of a non-recurring nature. The maximum allowable amount in the contingency reserve is 37.5 cents per thousand dollars of assessed valuation.

B. Unreserved Fund Balance

It is the City's policy to maintain a unreserved balance in each of the operating funds of the City (i.e., General, City Streets) at a level sufficient to provide for cash flow needs, a reasonable amount for emergent or unforeseen needs, and an orderly adjustment to adverse changes in revenues, including termination of revenue sources through actions of other governmental bodies. The Finance Director, in conjunction with the departments and the City Manager, will analyze fund balance requirements and recommend formal fund balance policies for each of the principal City funds. Fund balance policies will be reviewed at least every three years to ensure all relevant factors are being considered. Until such time as a thorough analysis has been completed for each fund, the City's policy will be to provide a minimum fund balance (combination of Contingency Reserve and Unreserved Fund Balance) of at least 10% of budgeted operating revenues for the General Fund and a minimum unreserved fund balance of 5% of budgeted operating revenues for other City operating funds.

C. Budgeted Operating Contingency

In order to provide for unforeseen expenditures or new opportunities throughout the year, the General Fund budget will have an operating contingency of \$250,000 that will be used only with City Council approval. Savings within departmental budgets throughout the year will be the first source for funding unforeseen expenditures or providing for new opportunities before the Operating Contingency is accessed.

D. Budgeted Insurance Reserve

A separate insurance reserve account will be budgeted within the General Fund budget to be used for potential substantial events (street damage, inverse condemnation, etc.) and infrastructure repair not covered by insurance policies or other sources such as FEMA. The budgeted amount should approximate 2% of the City's assets (not including roads and surface water utilities).

E. Budgeted Capital Improvement Contingency

A separate capital contingency account will be budgeted within each of the three capital improvement funds to be used for capital project adjustments and for project acceleration. The amount to be budgeted in each of the capital contingency accounts is equal to 10% of the total budgeted capital improvement projects within each fund for that year or \$200,000, whichever is less.

The City Manager may administratively approve expenditures from the contingency fund for any project, without changing the project scope, regardless of the percentage of the project budget, if the amount does not exceed \$10,000. In addition, the City Council delegates the authority to the City Manager to administratively approve dollar adjustments to individual capital projects that do not change the scope of project in an amount up to 10% of the project's adopted budget, not to exceed \$50,000.

VI. CAPITAL IMPROVEMENT PROGRAM PLAN POLICIES

A number of important policy considerations are the basis for the Capital Improvement Program (CIP) Plan. These policies provide guidelines for all financial aspects of the CIP, and ultimately affect the project selection process.

A. Relationship of Long-Range Plans to the CIP

The CIP will be updated annually as part of the City's budget process. The City Council may amend the CIP Plan at any time as required.

Virtually all of the projects included in the CIP are based upon formal long-range plans that have been adopted by the City Council. This ensures that the City's Capital Improvement Program, which is the embodiment of the recommendations of these individual planning studies, is responsive to the officially stated direction of the City Council as contained in the Comprehensive Plan, Council work goals, and supporting documents. Examples of these supporting documents: Pavement Management System Plan and the Parks and Open Space and Recreation Services Plan. There are exceptions, but they are relatively small when compared to the other major areas of expenditure noted above.

B. CIP Coordination Team

A CIP Coordination Team is a cross-departmental team which participates in the review and recommendation of the CIP program to the City Manager. The Team will review proposed capital projects in regards to accurate costing (design, capital, and operating), congruence with City objectives, and prioritize projects by a set of deterministic criteria. The Public Works Director, or his/her designee, will serve as the lead for the team.

C. Establishing CIP Priorities

The City uses the following basic CIP project prioritization and selection process:

1. Each CIP program area establishes criteria to be used in the prioritization of specific projects submitted for funding. These specific criteria are developed by staff in conjunction with City Council priorities and input from citizens, associated City boards and commissions. The criteria is identified in the City's budget document. The City has divided its CIP projects into the following program areas: General & Parks Capital Projects, Roads Capital Projects, and Surface Water Capital Projects.
2. Designated personnel within City departments recommend project expenditure plans to the Finance Department. The project expenditure plans include all capital costs and any applicable maintenance and operation expenditures along with a recommended funding source.
3. The CIP Coordination Team evaluates the various CIP projects and selects those with the highest priority based on input from citizens, project stakeholders, appropriate advisory committees, and City Council goals.
4. A Preliminary CIP Plan is developed by the Finance Department and is recommended to the City Council by the City Manager.
5. The City Council reviews the Operating and Preliminary CIP Plan, holds a public hearing(s) on the plan, makes their desired alterations, and then officially adopts the CIP and establishes related appropriations as a part of the City's budget.
6. Within the available funding, the highest priority projects are then selected and funded in the CIP.

D. Types of Projects Included in the CIP Plan

The CIP Plan will display, to the maximum extent possible, all major capital projects in which the City is involved. It is difficult to define precisely what characteristics a project should have before it is included in the CIP Plan for the public's and City Council's review and approval. While the following criteria may be used as a general guide to distinguish among projects which should be included or excluded from the CIP Plan, there are always exceptions which require management's judgment. Therefore, the City Manager has the administrative authority to determine which projects should be included in the CIP Plan and which projects are more appropriately contained in the City's operating budget.

For purposes of the CIP Plan, a CIP project is generally defined to be any project that possesses all of the following characteristics:

1. Exceeds an estimated cost of \$10,000;
2. Involves totally new physical construction, reconstruction designed to gradually and systematically replace an existing system on a piecemeal basis, replacement of a major component of an existing facility, or acquisition of land or structures; and
3. Involves City funding in whole or in part, or involves no City funds but is the City's responsibility for implementing, such as a 100% grant-funded project or 100% Local Improvement District funded project.
4. Involves the skills and construction needs beyond those needed for a general repair and maintenance project.

These should be considered general guidelines. Any project in excess of \$25,000 meeting the criteria of (2), (3) and (4) above, or various miscellaneous improvements of a like nature whose cumulative total exceeds \$25,000 (i.e., street overlays) should be considered as part of the CIP process.

Program area managers are responsible for the cost estimates of their proposed programs, including future maintenance and operations costs related to the implementation of completed projects.

- E. Scoping and Costing Based on Predesign Study
For some projects it is difficult to develop accurate project scopes, cost estimates, and schedules on which no preliminary engineering or community contact work has been done. To address this problem, some projects are initially proposed and funded only for preliminary engineering and planning work. This funding will not provide any monies to develop final plans, specifications, and estimates to purchase rights-of-way or to construct the projects. Future project costs are refined through the predesign study process.
- F. Required Project Features and Financial Responsibility: If a proposed project will cause a direct impact on other publicly-owned facilities, an equitable shared and funded cost plan must be coordinated between the affected program areas.
- G. Predictability of Project Timing, Cost and Scope: The predictability of timing and costs of projects is important to specific private developments, such as the provision of street improvements or the extension of major sewer lines or water supply, without which development could not occur. These projects generally involve significant financial contributions from such private development through developer extension agreements, LIDs, and other means. Once a project has been approved by the City Council in the CIP, project scheduling is a priority to maintain.

The City Council authorizes the City Manager to administratively approve the acceleration of project schedules so long as they can be accomplished within budgeted and any allowable contingency expenditures, with the understanding that all controversial issues will be brought before the City Council. All project additions or deletions must be approved by the City Council.

- H. CIP Maintenance and Operating Costs: CIP projects, as approved by the City Council, shall have a funding plan for maintenance and operating costs identified in the project description. These costs will be included in the City's long-term financial planning.
- I. Local Improvement Districts (LID)
Examples of when future LIDs may be formed are as follows: 1) where old agreements exist, committing property owners to LID participation on future projects; 2) when a group of property owners wish to accelerate development of a certain improvement; 3) when a group of property owners desire a higher standard of improvement than the City's project contemplates; or 4) when a group of property owners request City assistance in LID formation to fund internal neighborhood transportation facilities improvements, which may or may not have City funding involved. If City funding is proposed by the project sponsors (property owners), they shall so request of the City Council (through the City Clerk) in writing before any LID promotion activity begins. The City Manager shall analyze such request and report his conclusions and recommendation to Council for their consideration. The Council shall by motion affirm or deny the recommendation. The Council's affirmative motion to financially participate shall expire in 180 days, unless the project sponsors have submitted a sufficient LID petition by that time.

In the event that the request is for street resurfacing in advance of the City's normal street resurfacing cycle, the City's contribution, if any, will be determined based on a recommendation from the Public Work's Department and a financial analysis of the impact of completing the project prior to the City's original timeline.

On capital projects whose financing depends in part on an LID, interim financing will be issued to support the LID's portion of the project budget at the same time or in close proximity to the issuance of the construction contract. The amount of the interim financing shall be the current estimate of the final assessment roll as determined by the administering department.

In the event that the project is 100% LID funded, interim financing shall be issued either in phases (i.e., design phase and construction phase) or up front in the amount of the entire estimated final assessment roll, whichever means is estimated to provide the lowest overall cost to the project as determined by the Finance Department.

The City will recapture direct administrative costs incurred by the City for the LID project by including these in the preliminary and final assessment roles.

- J. Preserve Existing Capital Infrastructure Before Building New Facilities: It is the City's policy to ensure that adequate resources are allocated to preserve the City's existing infrastructure before targeting resources toward building new facilities that also have maintenance obligations. This policy addresses the need to protect the City's historical investment in capital facilities and to avoid embarking on a facility enhancement program which, together with the existing facilities, the City cannot afford to adequately maintain.
- K. New Facilities Should Be of High Quality, Low Maintenance, Least Cost: The intent of this policy is to guide the development and execution of the CIP Plan through an emphasis on lowest life-cycle cost. Projects should only be built if the necessary funding to operate them is provided. Also, priority is given to new facilities that have minimal ongoing maintenance costs so as to limit the impact upon both the CIP and the operating budget.
- L. Public Input at All Phases of Projects: The City makes a serious commitment to public involvement. The City's long-range plans are developed through an extensive citizen involvement program.
- M. Basis for Project Appropriations: During the City Council's CIP Plan review, the City Council will appropriate the full estimated project cost for all projects in the CIP Plan. Subsequent adjustments to appropriation levels for amendments to the CIP Plan may be made by the City Council at any time.
- N. Balanced CIP Plan: The CIP Plan is a balanced six-year plan. This means that for the entire six-year period, revenues will be equal to project expenditures in the plan. It is anticipated that the plan will have more expenditures than revenues in single years of the plan, but this imbalance will be corrected through the use of interim financing, if actually needed. Over the life of the six-year plan, however, all planned interim debt will be repaid and all plan expenditures, including interest costs on interim debt will be provided for with identified revenues. Any project funding plan, in which debt is not retired within the current six-year plan, must have specific City Council approval.
- O. Use of Debt in the CIP: The CIP is viewed as a long-term program that will continually address capital requirements far into the future. As such, the use of long-term debt should be minimized, allowing the City to put money into actual projects that benefit Shoreline residents and businesses rather than into interest payments to financial institutions. There may be exceptions to this policy for extraordinary circumstances, where voted or non-voted long-term debt must be issued to achieve major City goals that otherwise could not be achieved, or would have to wait an unacceptably long time. Issuance of long-term debt must receive City Council authorization.

- Staff monitors CIP cash flow regularly and utilizes fund balances to minimize the amount of borrowing required. Funds borrowed for cash flow purposes are limited to short-term obligations. Projected financing costs are included within a project in the administrative program area.
- P. Finance Director's Authority to Borrow: The Finance Director is authorized to initiate interim and long-term borrowing measures, as they become necessary, as identified in the CIP Plan and approved by the City Council.
- Q. CIP Plan Update and Amendment: The CIP Plan will be updated at least annually. The City Council may amend the CIP Plan at any time if a decision must be made and action must be taken before the next CIP review period. All project additions or deletions must be approved by the City Council.
- R. Formalization of Monetary Agreements: All agreements between the City and outside jurisdictions, where resources are exchanged shall be in writing specifying the financial terms of the agreement, the length of the agreement, and the timing of any required payments (i.e., Joint CIP projects where the City is the lead agency, grant funded projects, etc.). Formalization of these agreements will protect the City's interests. Program areas shall make every effort to promptly request any reimbursements that are due the City. Where revenues from outside jurisdictions are ongoing, these requests shall be made at least quarterly, unless alternative arrangements are approved by the City Manager or City Council.
- S. Applicable Project Charges: CIP projects should reflect all costs that can be clearly shown to be necessary and applicable. Staff charges to CIP projects will be limited to time spent actually working on those projects and shall include an overhead factor to cover the applicable portion of that person's operating cost.

VII. DEBT POLICY

The Objectives of the City's Debt Management Policy are:

- A. To limit the use of debt so that debt service payments will be a predictable and manageable part of the operating budget.
- B. To raise capital at the lowest cost, consistent with the need to borrow. This will be accomplished by:
 1. Keeping a high credit rating (while making attempts to strengthen credit rating).
 2. Maintaining a good reputation in the credit markets by adjusting the capital program for regular entry to the bond market and by managing the annual budget responsibly.
 3. Institute and maintain procedures that ensure full and timely repayment of City obligations.

General Debt Policies

Before issuing any debt, the City will consider the impacts of such debt on the operating budget, the effect on the City's credit rating, the debt capacity remaining under constitutional and statutory limitations, the most cost-effective term, structure, and type of debt, and the impact on taxpayers.

Disclosure statements will be used to keep taxpayers and investors informed of the City's financial position. These include printed copies of:

- A. Annual reports
- B. Operating budget and Capital Facilities Plan
- C. Official Statements

Debt issues will be sold on a competitive basis (except when conditions make a negotiated sale preferable) and awarded to the bidder who produces the lowest true interest cost.

Debt issues may be sold on a negotiated basis if the issue is unusually large or small, the project is complex, the issue is a refunding, flexibility is desired in the structure, the market is volatile, or other conditions make it in the City's best interest to conduct a negotiated sale.

Long Term Debt: Long term debt will be used to maintain and develop the municipal infrastructure when the economic life of a fixed asset exceeds five years.

Revenue bonds will generally be used for projects which are financially self-sustaining.

General Obligation bonds can be used to finance public works projects which benefit the community and where there are sufficient dedicated revenues to amortize the debt.

General Obligation pledges can be used to back self-sustaining projects financed through revenue bonds when costs can be reduced and the municipal credit rating is not put in jeopardy by this action.

The City will continue to rely on a strong local improvement district program for certain local or neighborhood street, water and sewer improvements.

The City will use interfund borrowing where such borrowing is cost effective to both the borrowing and the lending fund. Such borrowing shall implement Council directed policy in a simplified manner, such as borrowing associated with interim financing for local improvement district projects.

Mkt Adj. 3.78%

**City of Shoreline
Range Placement Table**

2.5% Between Ranges; 4% Between Steps

Salary Table 01 - EXEMPT

UPDATED OCT, 2006

Range	Title	Salary	Min Step 1	Step 2	Step 3	Step 4	Step 5	Max Step 6
1		Annual	17,410	18,125	18,840	19,580	20,371	21,188
2		Annual	17,869	18,559	19,299	20,065	20,856	21,699
3		Annual	18,278	19,018	19,784	20,575	21,392	22,260
4		Annual	18,737	19,503	20,269	21,086	21,928	22,822
5		Annual	19,222	19,988	20,805	21,622	22,490	23,383
6		Annual	19,707	20,473	21,316	22,158	23,052	23,971
7		Annual	20,218	21,009	21,852	22,720	23,639	24,583
8		Annual	20,729	21,545	22,388	23,307	24,226	25,196
9		Annual	21,214	22,082	22,949	23,868	24,839	25,834
10		Annual	21,775	22,643	23,537	24,481	25,451	26,472
11		Annual	22,286	23,205	24,124	25,094	26,089	27,136
12		Annual	22,847	23,766	24,736	25,706	26,753	27,825
13		Annual	23,435	24,379	25,349	26,370	27,417	28,515
14		Annual	24,022	24,966	25,987	27,034	28,106	29,229
15		Annual	24,609	25,604	26,625	27,698	28,795	29,944
16		Annual	25,247	26,268	27,315	28,387	29,536	30,710
17		Annual	25,885	26,906	27,978	29,102	30,276	31,476
18		Annual	26,498	27,570	28,668	29,816	31,016	32,267
19		Annual	27,162	28,259	29,382	30,557	31,782	33,058
20		Annual	27,851	28,974	30,123	31,348	32,599	33,901
21		Annual	28,540	29,689	30,889	32,114	33,390	34,743
22		Annual	29,280	30,429	31,654	32,931	34,233	35,611
23		Annual	29,995	31,195	32,446	33,748	35,101	36,505
24		Annual	30,761	31,961	33,263	34,590	35,969	37,398
25		Annual	31,501	32,778	34,080	35,458	36,862	38,343

**City of Shoreline
Range Placement Table**

2.5% Between Ranges; 4% Between Steps

Salary Table 01 - EXEMPT

UPDATED OCT, 2006

Range	Title	Salary	Min Step 1	Step 2	Step 3	Step 4	Step 5	Max Step 6
26		Annual	32,293	33,595	34,922	36,326	37,781	39,313
27		Annual	33,110	34,437	35,841	37,271	38,751	40,283
28		Annual	33,952	35,305	36,709	38,190	39,721	41,304
29		Annual	34,794	36,198	37,653	39,134	40,717	42,325
30		Annual	35,662	37,092	38,572	40,130	41,712	43,397
31		Annual	36,556	38,036	39,543	41,125	42,759	44,469
32		Annual	37,475	38,981	40,538	42,146	43,831	45,593
33		Annual	38,419	39,951	41,534	43,219	44,929	46,741
34		Annual	39,364	40,947	42,580	44,291	46,052	47,890
35		Annual	40,334	41,968	43,627	45,388	47,201	49,090
36		Annual	41,381	43,014	44,750	46,512	48,375	50,315
37		Annual	42,376	44,086	45,848	47,686	49,575	51,566
38		Annual	43,423	45,159	46,971	48,860	50,826	52,843
39		Annual	44,520	46,307	48,171	50,086	52,102	54,170
40		Annual	45,644	47,482	49,371	51,362	53,404	55,548
41	Planner I	Annual	46,792	48,681	50,622	52,638	54,732	56,927
42		Annual	47,967	49,881	51,872	53,940	56,085	58,357
43		Annual	49,167	51,132	53,174	55,293	57,514	59,812
44		Annual	50,392	52,409	54,502	56,672	58,944	61,292
45	Planner II Executive Assistant to the City Manager	Annual	51,643	53,710	55,855	58,101	60,424	62,849
46	Budget Analyst Management Analyst Staff Accountant Recreation Coordinator Grants Specialist	Annual	52,919	55,063	57,259	59,531	61,930	64,407
47	Human Resources Analyst	Annual	54,298	56,442	58,714	61,037	63,488	66,040
48	Purchasing Officer	Annual	55,625	57,846	60,169	62,569	65,070	67,674

City of Shoreline
Range Placement Table

2.5% Between Ranges; 4% Between Steps

Salary Table 01 - EXEMPT

UPDATED OCT, 2006

Range	Title	Salary	Min Step 1	Step 2	Step 3	Step 4	Step 5	Max Step 6
49	Coordinator Office of Neighborhoods Emergency Management Coordinator Planner III	Annual	57,029	59,301	61,675	64,126	66,704	69,359
50	Parks & Recreation Project Coordinator Communications Specialist Senior Accountant Recreation Coordinator II	Annual	58,433	60,756	63,207	65,734	68,363	71,095
51	Web Developer	Annual	59,888	62,288	64,790	67,368	70,074	72,882
52	Associate Traffic Engineer Public Works Administrative Manager Development Review Engineer	Annual	61,420	63,871	66,423	69,078	71,835	74,720
53	Customer Response Team Supervisor Network Administrator	Annual	62,952	65,453	68,083	70,814	73,648	76,583
54	PW Maintenance Supervisor	Annual	64,509	67,087	69,767	72,575	75,486	78,498
55	Capital Projects Manager I GIS Specialist Human Services Manager City Clerk	Annual	66,117	68,772	71,529	74,388	77,375	80,464
56	Parks Superintendent Recreation Superintendent Permit Services Manager	Annual	67,802	70,508	73,316	76,251	79,289	82,480
57	Database Administrator	Annual	69,487	72,269	75,154	78,166	81,280	84,548
58	Assistant City Attorney	Annual	71,223	74,056	77,017	80,106	83,323	86,641
59	Building Official Economic Development Program Mgr Finance Manager Capital Projects Manager II Surface Water & Enviro Services Manager Traffic Engineer	Annual	73,009	75,945	78,957	82,123	85,416	88,811
60		Annual	74,822	77,809	80,923	84,165	87,535	91,032
61		Annual	76,711	79,774	82,965	86,284	89,730	93,330
62	Information Systems Manager Assistant Director PADS	Annual	78,626	81,791	85,059	88,454	91,977	95,653
63		Annual	80,566	83,808	87,152	90,649	94,274	98,052

City of Shoreline
Range Placement Table

2.5% Between Ranges; 4% Between Steps

Salary Table 01 - EXEMPT

UPDATED OCT, 2006

Range	Title	Salary	Min Step 1	Step 2	Step 3	Step 4	Step 5	Max Step 6
64	Aurora Corridor Project Manager Communications & IR Director	Annual	82,608	85,901	89,347	92,921	96,623	100,503
65		Annual	84,650	88,045	91,568	95,219	99,048	103,005
66	City Engineer Public Works Operations Manager	Annual	86,769	90,241	93,866	97,618	101,524	105,583
67		Annual	88,964	92,513	96,214	100,069	104,077	108,212
68	Human Resources Director	Annual	91,160	94,810	98,588	102,545	106,655	110,918
69		Annual	93,457	97,184	101,064	105,123	109,310	113,701
70	Assistant City Manager	Annual	95,780	99,609	103,617	107,753	112,067	116,534
71		Annual	98,180	102,111	106,196	110,433	114,849	119,444
72	Finance Director Parks, Rec & Cultural Services Director Planning & Devel. Svcs. Director Public Works Director	Annual	100,656	104,664	108,850	113,216	117,734	122,431
73	City Attorney	Annual	103,158	107,293	111,582	116,049	120,670	125,495
74	Deputy City Manager	Annual	105,736	109,948	114,364	118,934	123,708	128,634
75		Annual	108,391	112,731	117,224	121,921	126,796	131,851

**City of Shoreline
Range Placement Table**

2.5% Between Ranges; 4% Between Steps Salary Table 02 - NON-EXEMPT

UPDATED OCT, 2006

Range	Title	Hourly Rate	Min Step 1	Step 2	Step 3	Step 4	Step 5	Max Step 6
1		Hourly	8.37	8.71	9.06	9.41	9.79	10.19
2		Hourly	8.59	8.92	9.28	9.65	10.03	10.43
3		Hourly	8.79	9.14	9.51	9.89	10.28	10.70
4		Hourly	9.01	9.38	9.74	10.14	10.54	10.97
5		Hourly	9.24	9.61	10.00	10.40	10.81	11.24
6		Hourly	9.47	9.84	10.25	10.65	11.08	11.52
7		Hourly	9.72	10.10	10.51	10.92	11.36	11.82
8		Hourly	9.97	10.36	10.76	11.21	11.65	12.11
9	Lifeguard/Instructor II	Hourly	10.20	10.62	11.03	11.48	11.94	12.42
10		Hourly	10.47	10.89	11.32	11.77	12.24	12.73
11		Hourly	10.71	11.16	11.60	12.06	12.54	13.05
12		Hourly	10.98	11.43	11.89	12.36	12.86	13.38
13		Hourly	11.27	11.72	12.19	12.68	13.18	13.71
14		Hourly	11.55	12.00	12.49	13.00	13.51	14.05
15		Hourly	11.83	12.31	12.80	13.32	13.84	14.40
16		Hourly	12.14	12.63	13.13	13.65	14.20	14.76
17		Hourly	12.44	12.94	13.45	13.99	14.56	15.13
18	Senior Lifeguard	Hourly	12.74	13.25	13.78	14.33	14.91	15.51
19		Hourly	13.06	13.59	14.13	14.69	15.28	15.89
20		Hourly	13.39	13.93	14.48	15.07	15.67	16.30
21		Hourly	13.72	14.27	14.85	15.44	16.05	16.70
22		Hourly	14.08	14.63	15.22	15.83	16.46	17.12
23		Hourly	14.42	15.00	15.60	16.22	16.88	17.55
24		Hourly	14.79	15.37	15.99	16.63	17.29	17.98
25		Hourly	15.14	15.76	16.38	17.05	17.72	18.43
26		Hourly	15.53	16.15	16.79	17.46	18.16	18.90

**City of Shoreline
Range Placement Table**

2.5% Between Ranges; 4% Between Steps

Salary Table 02 - NON-EXEMPT

UPDATED OCT, 2006

Range	Title	Hourly Rate	Min Step 1	Step 2	Step 3	Step 4	Step 5	Max Step 6
27	Teen Program Assistant Recreation Assistant I	Hourly	15.92	16.56	17.23	17.92	18.63	19.37
28		Hourly	16.32	16.97	17.65	18.36	19.10	19.86
29	Administrative Assistant I	Hourly	16.73	17.40	18.10	18.81	19.58	20.35
30		Hourly	17.15	17.83	18.54	19.29	20.05	20.86
31	Recreation Assistant II Parks Maintenance Worker I Administrative Assistant I	Hourly	17.57	18.29	19.01	19.77	20.56	21.38
32	Public Works Maintenance Worker I	Hourly	18.02	18.74	19.49	20.26	21.07	21.92
33	Finance Technician Administrative Assistant II	Hourly	18.47	19.21	19.97	20.78	21.60	22.47
34	Technical Assistant	Hourly	18.92	19.69	20.47	21.29	22.14	23.02
35	Capital Projects Technician Accounts Payable/Payroll Technician Parks Maintenance Worker II Recreation Assistant III Finance Technician Administrative Assistant II	Hourly	19.39	20.18	20.97	21.82	22.69	23.60
36		Hourly	19.89	20.68	21.51	22.36	23.26	24.19
37	Administrative Assistant III Public Works Maintenance Worker II Accounts Payable/Payroll Technician Capital Projects Technician	Hourly	20.37	21.20	22.04	22.93	23.83	24.79
38	Payroll Officer Technical Assistant	Hourly	20.88	21.71	22.58	23.49	24.44	25.41
39	Senior Parks Maintenance Worker Facilities Maintenance Worker II Payroll Officer Administrative Assistant III	Hourly	21.40	22.26	23.16	24.08	25.05	26.04
40	Project Inspector I Engineering Technician	Hourly	21.94	22.83	23.74	24.69	25.68	26.71
41	CRT Representative Surface Water Quality Specialist	Hourly	22.50	23.40	24.34	25.31	26.31	27.37
42	Deputy City Clerk Sr. Public Works Maintenance Worker Records and Information Manager	Hourly	23.06	23.98	24.94	25.93	26.96	28.06

**City of Shoreline
Range Placement Table**

2.5% Between Ranges; 4% Between Steps Salary Table 02 - NON-EXEMPT

UPDATED OCT, 2006

Range	Title	Hourly Rate	Min Step 1	Step 2	Step 3	Step 4	Step 5	Max Step 6
43	Environmental Educator Right-of-Way Inspector Lead Customer Response Team Rep CRT Representative	Hourly	23.64	24.58	25.56	26.58	27.65	28.76
44	Code Enforcement Officer Plans Examiner I	Hourly	24.23	25.20	26.20	27.25	28.34	29.47
45	Planner II Lead CRT Representative	Hourly	24.83	25.82	26.85	27.93	29.05	30.22
46	Recreation Coordinator Project Inspector II Code Enforcement Officer	Hourly	25.44	26.47	27.53	28.62	29.77	30.96
47	Computer/Network Specialist	Hourly	26.10	27.14	28.23	29.34	30.52	31.75
48	Plans Examiner II Combination Inspector	Hourly	26.74	27.81	28.93	30.08	31.28	32.54
49	Facilities Supervisor	Hourly	27.42	28.51	29.65	30.83	32.07	33.35
50		Hourly	28.09	29.21	30.39	31.60	32.87	34.18
51		Hourly	28.79	29.95	31.15	32.39	33.69	35.04
52	Plans Examiner III	Hourly	29.53	30.71	31.93	33.21	34.54	35.92
53		Hourly	30.27	31.47	32.73	34.05	35.41	36.82
54		Hourly	31.01	32.25	33.54	34.89	36.29	37.74
55		Hourly	31.79	33.06	34.39	35.76	37.20	38.68
56		Hourly	32.60	33.90	35.25	36.66	38.12	39.65
57		Hourly	33.41	34.74	36.13	37.58	39.08	40.65
58		Hourly	34.24	35.60	37.03	38.51	40.06	41.65
59		Hourly	35.10	36.51	37.96	39.48	41.07	42.70
60		Hourly	35.97	37.41	38.91	40.46	42.08	43.77
61		Hourly	36.88	38.35	39.89	41.48	43.14	44.87
62		Hourly	37.80	39.32	40.89	42.53	44.22	45.99
63		Hourly	38.73	40.29	41.90	43.58	45.32	47.14
64		Hourly	39.72	41.30	42.96	44.67	46.45	48.32
65		Hourly	40.70	42.33	44.02	45.78	47.62	49.52
66		Hourly	41.72	43.38	45.13	46.93	48.81	50.76

**City of Shoreline
Range Placement Table**

2.5% Between Ranges; 4% Between Steps Salary Table 02 - NON-EXEMPT

UPDATED OCT, 2006

Range	Title	Hourly Rate	Min Step 1	Step 2	Step 3	Step 4	Step 5	Max Step 6
67		Hourly	42.77	44.48	46.26	48.11	50.04	52.03
68		Hourly	43.83	45.58	47.40	49.30	51.28	53.33
69		Hourly	44.93	46.72	48.59	50.54	52.55	54.66
70		Hourly	46.05	47.89	49.82	51.80	53.88	56.03
71		Hourly	47.20	49.09	51.06	53.09	55.22	57.43
72		Hourly	48.39	50.32	52.33	54.43	56.60	58.86
73		Hourly	49.60	51.58	53.65	55.79	58.01	60.33
74		Hourly	50.83	52.86	54.98	57.18	59.47	61.84
75		Hourly	52.11	54.20	56.36	58.62	60.96	63.39

**City of Shoreline Planning and Development Services
Fee Schedule (Page 1 of 5)**

Type of Permit Application	2006 Fee Schedule	2007 Proposed Fee Schedule
	Fee (based on \$127.00 per hour)	Fee (based on \$132.25 per hour)
Appeals		
Appeals	\$390.00	moved under Miscellaneous
Building		
Building Permit	Minimum fee is \$127.00	Pursuant to section 3.01.010(B)
Structural Plan Review	65% of the building permit fee	65% of the building permit fee
Civil Plan Review, Commercial (if applicable)		Hourly rate, 5 Hour Minimum (\$661.25)
Civil Plan Review, Residential (if applicable)		Hourly rate, 3 Hour Minimum (\$396.75)
All Other Plan Reviews or Work	Hourly rate, 1-hour minimum (\$127.00)	moved under Miscellaneous - renamed as "all Other Fees Per Hour"
ELECTRICAL		
Electrical Permit	Permit fee described in WAC 296-46B-905, plus a 20% handling fee	Permit fee described in WAC 296-46B-905, plus a 20% administrative fee
FIRE		
Automatic Fire Alarm System:		
Existing System		
New or relocated devices up to 5	Hourly rate, 1-hour minimum (\$127.00)	Hourly rate, 1-hour minimum (\$132.25)
New or relocated devices 6 up to 12	Hourly rate, 3-hour minimum (\$381.00)	Hourly rate, 3-hour minimum (\$396.75)
Each additional new or relocated device over 12	\$5.00 per device	\$5.25 per device
New System	Hourly rate, 4-hour minimum (\$508.00)	Hourly rate, 4-hour minimum (\$529.00)
Each additional new or relocated device over 30	\$5.00 per device	\$5.25 per device
Fire Extinguishing Systems:		
Commercial Cooking Hoods		
1 to 12 flow points	Hourly rate, 3-hour minimum (\$381.00)	Hourly rate, 3-hour minimum (\$396.75)
More than 12	Hourly rate, 4-hour minimum (\$508.00)	Hourly rate, 4-hour minimum (\$529.00)
Other Fixed System Locations	Hourly rate, 4-hour minimum (\$508.00)	Hourly rate, 4-hour minimum (\$529.00)
Fire Pumps:		
Commercial Systems	Hourly rate, 4-hour minimum (\$508.00)	Hourly rate, 4-hour minimum (\$529.00)
Commercial Flammable/Combustible Liquids:		
Aboveground Tank Installations		
First tank	Hourly rate, 2-hour minimum (\$254.00)	Hourly rate, 2-hour minimum (\$264.50)
Additional	Hourly rate, 1-hour minimum (\$127.00)	Hourly rate, 1-hour minimum (\$132.25)
Underground Tank Installations		
First tank		Hourly rate, 2-hour minimum (\$264.50)
Additional		Hourly rate, 1-hour minimum (\$132.25)
Underground Tank Piping (with new tank)	Hourly rate, 2-hour minimum (\$254.00)	Hourly rate, 2-hour minimum (\$264.50)
Underground Tank Piping Only (vapor recovery)	Hourly rate, 3-hour minimum (\$381.00)	Hourly rate, 3-hour minimum (\$396.75)
Underground Tank Removal		
First tank	Hourly rate, 2-hour minimum (\$254.00)	Hourly rate, 2-hour minimum (\$264.50)
Additional tank	\$65.00 per additional tank	\$66.25 per additional tank
Compressed Gas Systems (exception: medical gas systems require a plumbing)		
Excess of quantities in IFC Table 105.6.9	Hourly rate, 2-hour minimum (\$254.00)	Hourly rate, 2-hour minimum (\$264.50)
High-Piled Storage:		
Class I – IV Commodities:		
501 – 2,500 square feet	Hourly rate, 2-hour minimum (\$254.00)	Hourly rate, 2-hour minimum (\$264.50)
2,501 – 12,000 square feet	Hourly rate, 3-hour minimum (\$381.00)	Hourly rate, 3-hour minimum (\$396.75)
Over 12,000 square feet	Hourly rate, 4-hour minimum (\$508.00)	Hourly rate, 4-hour minimum (\$529.00)

**City of Shoreline Planning and Development Services
Fee Schedule (Page 2 of 5)**

Type of Permit Application	2006 Fee Schedule	2007 Proposed Fee Schedule
	Fee (based on \$127.00 per hour)	Fee (based on \$132.25 per hour)
High Hazard Commodities:		
501 – 2,500 square feet	Hourly rate, 3-hour minimum (\$381.00)	Hourly rate, 3-hour minimum (\$396.75)
Over 2,501 square feet	Hourly rate, 5-hour minimum (\$635.00)	Hourly rate, 5-hour minimum (\$661.25)
Underground Fire Mains and Hydrants	Hourly rate, 3-hour minimum (\$381.00)	Hourly rate, 3-hour minimum (\$396.75)
Industrial Ovens:		
Class A or B Furnaces	Hourly rate, 2-hour minimum (\$254.00)	Hourly rate, 2-hour minimum (\$264.50)
Class C or D Furnaces	Hourly rate, 4-hour minimum (\$508.00)	Hourly rate, 4-hour minimum (\$529.00)
LPG (Propane) Tanks:		
Commercial, less than 500-Gallon Capacity	Hourly rate, 2-hour minimum (\$254.00)	Hourly rate, 2-hour minimum (\$264.50)
Commercial, 500-Gallon+ Capacity	Hourly rate, 3-hour minimum (\$381.00)	Hourly rate, 3-hour minimum (\$396.75)
Commercial, Temporary	Hourly rate, 1-hour minimum (\$127.00)	Hourly rate, 1-hour minimum (\$132.25)
Residential 0 – 500-Gallon Capacity	Hourly rate, 1-hour minimum (\$127.00)	Hourly rate, 1-hour minimum (\$132.25)
Spray Booth	Hourly rate, 4-hour minimum (\$508.00)	Hourly rate, 4-hour minimum (\$529.00)
Sprinkler Systems (each riser):		
New Systems	Hourly rate, 5-hour minimum (\$635.00), plus \$3.00 per head	Hourly rate, 5-hour minimum (\$661.25), plus \$3.00 per head
Existing Systems		
1 – 10 heads	Hourly rate, 3-hour minimum (\$381.00)	Hourly rate, 3-hour minimum (\$396.75)
11 – 20 heads	Hourly rate, 4-hour minimum (\$508.00)	Hourly rate, 4-hour minimum (\$529.00)
More than 20 heads	Hourly rate, 5-hour minimum (\$635.00), plus \$3.00 per head	Hourly rate, 5-hour minimum (\$661.25), plus \$3.00 per head
Residential (R-3) 13-D System		
1 – 30 heads	Hourly rate, 3-hour minimum (\$381.00)	Hourly rate, 3-hour minimum (\$396.75)
More than 30 heads	Hourly rate, 3-hour minimum (\$381.00), plus \$3.00 per head	Hourly rate, 3-hour minimum (\$396.75), plus \$3.00 per head
Voluntary 13-D Systems in residences when not otherwise required		Hourly rate, 1-hour minimum (\$132.25)
Standpipe Systems	Hourly rate, 4-hour minimum (\$508.00)	Hourly rate, 4-hour minimum (\$529.00)
Temporary Tents and Canopies	Hourly rate, 1-hour minimum (\$127.00)	Hourly rate, 1-hour minimum (\$132.25)
MECHANICAL		
Residential Mechanical System Base	Hourly rate, 1-hour minimum (\$127.00)	Hourly rate, 1-hour minimum (\$132.25) (including 4 pieces of equipment), \$10.00 per piece of equipment over 4
Residential Fireplace (up to two)	Hourly rate, 1-hour minimum (\$127.00)	Included in fee line item above
Commercial Mechanical System Base	Hourly rate, 3-hour minimum (\$381.00)	Hourly rate, 3-hour minimum (\$396.75) (including 4 pieces of equipment), \$10.00 per piece of equipment over 4
All Other Mechanical (Residential and Commercial)	Hourly rate, 1-hour minimum (\$127.00)	Hourly rate, 1-hour minimum (\$132.25)
Planned Action Determination	Hourly rate, 1-hour minimum (\$127.00)	moved under Land Use category
PLUMBING		
Plumbing Systems Base	Hourly rate, 1-hour minimum (\$127.00)	Hourly rate, 1-hour minimum (\$132.25) (including 4 fixtures), \$10.00 per fixture over 4
Gas Piping Systems Base <u>standalone permit</u>	Hourly rate, 1-hour minimum (\$127.00)	Hourly rate, 1-hour minimum (\$132.25) (including 4 outlets), \$10.00 per outlet over 4
Backflow Prevention Device Base - standalone permit over 4	Hourly rate, 1-hour minimum (\$127.00)	Hourly rate, 1-hour minimum (\$132.25) (including 4 devices), \$10.00 per device

**City of Shoreline Planning and Development Services
Fee Schedule (Page 3 of 5)**

Type of Permit Application	2006 Fee Schedule	2007 Proposed Fee Schedule
	Fee (based on \$127.00 per hour)	Fee (based on \$132.25 per hour)
<u>Backflow Prevention Device as part of a plumbing systems permit</u>		\$10.00 per outlet
Environmental Review		
Environmental Checklist (SEPA):		
Single-Family	Hourly rate, 10-hour minimum (\$1,270)	Hourly rate, 10-hour minimum (\$1,322.50)
Multifamily/Commercial	Hourly rate, 15-hour minimum (\$1,905)	Hourly rate, 15-hour minimum (\$1,983.75)
Environmental Impact Statement Review	Hourly rate, 35-hour minimum (\$4,445)	Hourly rate, 35-hour minimum (\$4,628.75)
LAND USE		
Accessory Dwelling Unit	Hourly rate, 1-hour minimum (\$127.00)	Hourly rate, 1-hour minimum (\$132.25)
Adult Family Home	Hourly rate, 2-1/2-hour minimum (\$318.00)	Hourly rate, 2-1/2-hour minimum (\$330.75)
Clearing and Grading Permit	Hourly rate, 3-hour minimum (\$381.00)	moved under Site Development category
Comprehensive Plan Amendment – Site Specific	Hourly rate, 60-hour minimum (\$7,620), plus public hearing (\$1,950)	Hourly rate, 60-hour minimum (\$7,935), plus public hearing (\$2,032)
Conditional Use Permit (CUP)	Hourly rate, 30-hour minimum (\$3,810), plus public hearing (\$1,950)	Hourly rate, 30-hour minimum (\$3,967.50)
Continuation and/or Minor Alteration of Nonconforming Use	Hourly rate, 1-hour minimum (\$127.00)	no longer applicable
Critical Areas Reasonable Use Permit (CARUP)	Hourly rate, 8-hour minimum (\$1,016)	Hourly rate, 60-hour minimum (\$7,935), plus public hearing (\$2,032)
Critical Areas Special Use Permit (CASUP)	Hourly rate, 8-hour minimum (\$1,016)	Hourly rate, 60 hour minimum (\$7,935), plus public hearing (\$2,032)
<u>Director's Decision, written</u>		Hourly rate, 1-hour minimum (\$132.25)
Home Occupation, Bed and Breakfast, Boarding House	Hourly rate, 1-hour minimum (\$127.00)	Hourly rate, 1-hour minimum (\$132.25)
<u>Interpretation of Development Code</u>		Hourly rate, 1-hour minimum (\$132.25)
Master Plan	Hourly rate, 60-hour minimum (\$7,620), plus public hearing (\$1,950)	Hourly rate, 60-hour minimum (\$7,935), plus public hearing (\$2,032)
<u>Planned Action Determination</u>		Hourly rate, 1-hour minimum (\$132.25)
Rezone	Hourly rate, 60-hour minimum (\$7,620), plus public hearing (\$1,950)	Hourly rate, 60-hour minimum (\$7,935), plus public hearing (\$2,032)
SCTF Special Use Permit (SUP)	Hourly rate, 60-hour minimum (\$7,620), plus public hearing (\$1,950)	Hourly rate, 60-hour minimum (\$7,935), plus public hearing (\$2,032)
Sign Permit	Hourly rate, 2-hour minimum (\$254.00)	Hourly rate, 2-hour minimum (\$264.50)
Special Use Permit	Hourly rate, 50-hour minimum (\$6,350), plus public hearing (\$1,950)	Hourly rate, 60-hour minimum (\$7,935), plus public hearing (\$2,032)
Street Vacation	Hourly rate, 40-hour minimum (\$5,080), plus public hearing if required (\$1,950)	Hourly rate, 60-hour minimum (\$7,935), plus public hearing if required (\$2,032)
Temporary Use Permit (TUP)	Hourly rate, 2-hour minimum (\$254.00)	Hourly rate, 2-hour minimum (\$364.50)
Variance - Engineering Standards	Hourly rate, 3-hour minimum (\$381.00)	Hourly rate, 3-hour minimum (\$396.75)
Variances - Zoning	Hourly rate, 30-hour minimum (\$3,810), plus public hearing if required (\$1,950)	Hourly rate, 30-hour minimum (\$3,967.50)
MISCELLANEOUS FEES		
<u>Interpretation of Development Code</u>	Hourly rate, 1-hour minimum (\$127.00)	moved under Land Use category
<u>Pre-Application Meeting</u>	Hourly rate, 1-hour minimum (\$127.00)	no longer applicable
<u>Permit Fee for Work Commenced Without a Permit</u>	Twice the Applicable Permit Fee	Twice the Applicable Permit Fee
<u>Appeals</u>		\$406.50
<u>Expedited Review – Building or Site Development Permits</u>		Twice the applicable permit fee(s)
<u>Permit Fee for Work Commenced Without a Permit</u>		Twice the applicable permit fee(s)

**City of Shoreline Planning and Development Services
Fee Schedule (Page 4 of 5)**

Type of Permit Application	2006 Fee Schedule	2007 Proposed Fee Schedule
	Fee (based on \$127.00 per hour)	Fee (based on \$132.25 per hour)
All Other Fees Per Hour	Hourly rate, 1-hour minimum (\$127.00)	Hourly rate, 1-hour minimum (\$132.25)
RIGHT OF WAY		
Right-of-Way Use	Hourly rate, 1-hour minimum (\$127.00)	Hourly rate, 1-hour minimum (\$132.25)
Right-of-Way Site	Hourly rate, 2-hour minimum (\$254.00)	Hourly rate, 2-hour minimum (\$264.50)
SHORELINE SUBSTANTIAL DEVELOPMENT		
Shoreline Conditional Permit Use	Hourly rate, 30-hour minimum (\$3,810)	Hourly rate, 30-hour minimum (\$3,967.50)
Shoreline Exemption	Hourly rate, 2-hour minimum (\$254.00)	Hourly rate, 2-hour minimum (\$264.50)
Shoreline Variance	Hourly rate, 30-hour minimum (\$3,810), plus public hearing if required (\$1,950)	Hourly rate, 30-hour minimum (\$3,967.50), plus public hearing if required (\$2,032)
Substantial Development Permit (based on valuation):		
up to \$10,000	Hourly rate, 15-hour minimum (\$1,905)	Hourly rate, 15-hour minimum (\$1,983.75)
\$10,000 to \$500,000	Hourly rate, 34-hour minimum (\$4,318)	Hourly rate, 34-hour minimum (\$4,496.50)
over \$500,000	Hourly rate, 60-hour minimum (\$7,620)	Hourly rate, 60-hour minimum (\$7,935)
SITE DEVELOPMENT		
Grading		Hourly rate, 3-hour minimum (\$396.75)
Clearing		Hourly rate, 3-hour minimum (\$396.75)
Landscaping		Hourly rate, 3-hour minimum (\$396.75)
Parking Lot		Hourly rate, 3-hour minimum (\$396.75)
Subdivision Construction		Hourly rate, 12-hour minimum (\$1,587)
SUBDIVISIONS		
Binding Site Plan	Hourly rate, 6-hour minimum (\$762.00)	Hourly rate, 6-hour minimum (\$793.50)
Lot Line Adjustment	Hourly rate, 5-hour minimum (\$635.00)	Hourly rate, 5-hour minimum (\$661.25)
Preliminary Short Subdivision	Hourly rate, 30-hour minimum (\$3,810) for two-lot short plat ~ Hourly rate, 3-hour minimum (\$381.00) for each additional lot, plus public hearing if required (\$1,950)	Hourly rate, 30-hour minimum (\$3,967.50) for two-lot short subdivision plus 3-hour minimum (\$396.75) for each additional lot
Final Short Subdivision	Hourly rate, 8-hour minimum (\$1,016.00)	Hourly rate, 8-hour minimum (\$1,058.00)
Site Development (Engineering Plans Review and Inspections)	Hourly rate, 12-hour minimum (\$1,524)	moved under "Building" category - renamed Civil Plan Review (Commercial or Residentail)
Short Plat Change	Hourly rate, 12-hour minimum (\$1,524)	Replaced with "Changes to Preliminary Short or Formal Subdivision"
Preliminary Subdivision	Hourly rate, 38-hour minimum (\$4,826), plus \$34.00/lot, plus public hearing (\$1,950)	Hourly rate, 39-hour minimum (\$5,157.75) for five-lot subdivision plus 3-hour minimum (\$396.75) for each additional lot
Final Subdivision	Hourly rate, 30-hour minimum (\$3,810), plus \$21.00/lot	Hourly rate, 30-hour minimum (\$3,967.50)
Changes to Preliminary Short or Formal Subdivision		Hourly rate, 12-hour minimum (\$1,587)
MISCELLANEOUS FEES		
BUILDING PERMIT		
Valuation *The Total Valuation is the "Building permit valuations" as delineated in section R108.3 of the International Residential Code and section 108.3 of the International Building Code.		
\$1.00 - \$500		\$23.50
\$501 - \$2,000		\$23.50 for the first \$500.00 + \$3.05 for each additional \$100.00, or fraction thereof, to and including \$2,000.00.

**City of Shoreline Planning and Development Services
Fee Schedule (Page 5 of 5)**

Type of Permit Application	2006 Fee Schedule	2007 Proposed Fee Schedule
	Fee (based on \$127.00 per hour)	Fee (based on \$132.25 per hour)
\$2,001 - \$25,000		\$69.25 for the first \$2,000, + \$14.00 for each additional \$1,000.00 or fraction thereof, to and including \$25,000.00.
\$25,001 - \$50,000		\$391.25 for the first \$25,000.00 + \$10.10 for each additional \$1,000.00, or fraction thereof, to and including \$50,000.00.
\$50,001 - \$100,000		\$643.75 for the first \$50,000.00 + \$7.00 for each additional \$1,000.00, or fraction thereof, to and including \$100,000.00.
\$100,001 - \$500,000		\$993.75 for the first \$100,000.00 + \$5.60 for each additional \$1,000.00, or fraction thereof, to and including \$500,000.00.
\$500,001 - \$1,000,000		\$3,233.75 for the first \$500,000.00 + \$4.75 for each additional \$1,000.00, or fraction thereof, to and including \$1,000,000.00.
\$1,000,001 +		\$5,608.75 for the first \$1,000,000 + \$3.15 for each additional \$1,000.00, or fraction thereof.
SUPPLEMENTAL FEES		
	Projects that exceed the normal limits of anticipated work hours required for plans review or inspections because of scale or complexity may be assessed additional fees. All fees are calculated at \$127.00 per hour, minimum one hour.	Projects that exceed the normal limits of anticipated work hours required for plans review or inspections because of scale or complexity may be assessed additional fees. All fees are calculated at \$132.25 per hour
	Reinspection fees may be assessed if work is incomplete, corrections not completed or the allotted time is depleted. Fees will be assessed at \$127.00 per hour, minimum one hour.	Reinspection fees may be assessed if work is incomplete, corrections not completed or the allotted time is depleted. Fees will be assessed at \$132.25 per hour, minimum one hour.
FEE REFUNDS		
	The city manager or designee may authorize the refunding of: <ol style="list-style-type: none"> 1. One hundred percent of any fee erroneously paid or collected. 2. Up to 80 percent of the permit fee paid when no work has been done under a permit issued in accordance with this code. 3. Up to 80 percent of the plan review fee paid when an application for a permit for which a plan review fee has been paid is withdrawn or canceled before any plan reviewing is done. 4. The city manager or designee shall not authorize refunding of any fee paid except on written application filed by the original permittee not later than 180 days after the date of fee payment. 	

2007 Parks Fee Schedule Part 1 of 4 (Page 1 of 4)				
2007 Proposed Park Facility Rental and Drop-in Fee Schedule				
Fee	2006 Resident Rate	2006 Non-Resident Rate	2007 Proposed Resident Rate	2007 Proposed Non-Resident Rate
Outdoor Rental Fees:				
Picnic Shelters – (same for all groups)				
Half Day	\$40	\$44.00	\$42	\$46
Full Day	\$60	\$66.00	\$63	\$69
Athletic Fields				
Lights (determined by dusk schedule)	\$14.50	\$14.50	\$15	\$15
Senior/Youth League Game and/or Practice	\$3.00	\$3.50	\$3	\$4
Adult Practice	\$13.00	\$14.50	\$14	\$15
Adult League	\$25.00	\$27.50	\$26	\$29
Shoreline A & B				
Resident Youth - Per Hour	\$15.00		\$15	
Non-Resident Youth - Per Hour		\$20.00		\$20
Resident Adult - Per Hour	\$27.50		\$27.50	
Non-Resident Adult - Per Hour		\$55.00		\$55
Discount Field Rate Resident - Per Hour	\$15.00		\$15	
Discount Field Rate Non- Resident - Per Hour		\$20.00		\$20
Indoor Rental Fees:				
Richmond Highlands (same for all groups) –				
Maximum Attendance 214				
Entire Building (including building monitor)	\$50.00	\$55.00	\$52	\$57
Gym Only	\$40.00	\$44.00	\$42	\$46
Café/Game Room	\$40.00	\$44.00	\$42	\$46
Spartan Recreation Center				
Spartan Recreation Center Fees for Youth Organizations				
Multi-Purpose Room 1	\$10.00	\$11.00	\$10	\$11
Multi-Purpose Room 1 w/Kitchen	\$16.00	\$17.50	\$17	\$18
Multi-Purpose Room 2	\$10.00	\$11.00	\$10	\$11
Multi-Purpose Room 2 w/Kitchen	\$16.00	\$17.50	\$17	\$18
Gymnastics Room	\$10.00	\$11.00	\$10	\$11
Dance Room	\$10.00	\$11.00	\$10	\$11
Gym-One Court	\$15.00	\$16.50	\$16	\$17
Entire Gym	\$30.00	\$33.00	\$31	\$34
Entire Facility	\$77.00	\$85.00	\$80	\$89
Basic Party Package (Includes 8 People)	\$80.00	\$86.00	\$83	\$90
Extra Individual	\$1.50	\$1.50	\$2	\$2
Deluxe Party Package (Includes 8 People)	\$180.00	\$186.00	\$188	\$194
Custom Party Package (Includes 8 People)	\$210.00	\$216.00	\$219	\$225
Extra Individual	\$9.00	\$9.00	\$9	\$9

2007 Parks Fee Schedule Part 2 of 4 (Page 2 of 4)				
2007 Proposed Park Facility Rental and Drop-in Fee Schedule				
Fee	2006 Resident Rate	2006 Non-Resident Rate		
Spartan Recreation Center Fees for Adult Groups:				
Multi-Purpose Room 1	\$20	\$22.00	\$21	\$23
Multi-Purpose Room 1 w/Kitchen	\$29	\$32.00	\$30	\$33
Multi-Purpose Room 2	\$20	\$22.00	\$21	\$23
Multi-Purpose Room 2 w/Kitchen	\$29	\$32.00	\$30	\$33
Gymnastics Room	\$20	\$22.00	\$21	\$23
Dance Room	\$20	\$22.00	\$21	\$23
Gym-One Court	\$29	\$32.00	\$30	\$33
Entire Gym	\$55	\$60.00	\$57	\$63.00
Entire Facility	\$105	\$115.00	\$109.00	\$120.00
*Rentals outside the normal operating hours of the Spartan Gym may require an additional supervision fee. (See Below)				
Other Indoor Rental Fees:				
Damage Deposit: (refundable)	\$175	\$175.00	\$182.00	\$182.00
Supervision Fee (if applicable)	\$16.00	\$16.00	\$17.00	\$17.00
Daily Rates	Not to Exceed \$700.00/Day	Not to Exceed \$700.00/Day	\$730.00	\$730.00
Spartan Gym Tarp Installation	\$55.00	\$55.00		
Concession / Admission / Sales During Indoor Facility Use:	Not to exceed \$100/day	Not to exceed \$100/day		
20% of the gross revenue collected will be remitted to the City of Shoreline if concession sales are charged on-site by the individuals or organizations renting a City-owned facility.				
20% of the gross revenue collected will be remitted to the City of Shoreline if spectator admissions are charged on-site by the individuals or organizations renting a City-owned facility.				
20% of the gross amount will be remitted to the City of Shoreline if an individual or organization rents a City facility for a clinic, camp, or a class where the participants are charged a fee.				
Any individual or organization that is required to pay concession / admission fee must complete the appropriate permit application.				
Concession/Admission/Sales Fees may be modified at the discretion of the Director of Shoreline Parks and Recreation.				
Drop-In Fees:				
Showers Only	\$1	\$1.00	\$1.00	\$1.00
Youth Drop-In	\$1	\$1.00	\$1.00	\$1.00
Youth Drop-In Ten Punch Card	\$8	\$9.00	\$8.50	\$9.50
Youth Drop-In Three Month Pass	\$20	\$22.00	\$21.00	\$23.00
Adult Drop-In	\$20	\$25.00	\$21.00	\$26.00
Adult Drop-In Ten Punch Card	\$18	\$22.00	\$19.00	\$23.00
Adult Drop-In Three Month Pass	\$46	\$50.00	\$48.00	\$52.00

2007 Parks Fee Schedule Part 3 of 4 (Page 3 of 4)				
2007 Proposed Aquatics Drop-in Fee Schedule				
Drop in Fees	Proposed 2006 Resident Rate	Proposed 2006 Non-Resident Rate	Proposed 2007 Resident Rate	Proposed 2007 Non-Resident Rate
Adult	\$3.25	\$3.75	\$3.50	\$4.00
Child/Senior/Disabled	\$2.25	\$2.50	\$2.50	\$2.75
Family	\$8.00	\$9.00	\$8.50	\$9.50
Adult - Real Deal	\$1.50	\$2.00	\$1.75	\$2.25
Child/Senior/Disabled - Real Deal	\$1.00	\$1.25	\$1.25	\$1.50
Adult - 10 punch	\$26.00	\$30.00	\$27.25	\$31
Child/Senior/Disabled - 10 Punch	\$18.00	\$22.00	\$19	\$23
Family - 10 Punch	\$64.00	\$72.00	\$67	\$75
1 Month				
Adult - 1 mo	\$44.00	\$48.00	\$46	\$50
Child/Senior/Disabled - 1 mo	\$26.00	\$28.50	\$27	\$30
Family -1 mo	\$108.00	\$121.00	\$113	\$126
3 Month				
Adult -3 month	\$117.00	\$135.00	\$122	\$141
Child/Senior/Disabled - 3 mo	\$78.00	\$99.00	\$81	\$103
Family -3 mo	\$234.00	\$270.00	\$244	\$281
6 Month				
Adult -6 month	\$189.00	\$202.00	\$197	\$210
Child/Senior/Disabled - 6 mo	\$135.00	\$148.00	\$141	\$154
Family -6 mo	\$378.00	\$405.00	\$394	\$422
1 Year Pass				
Adult -	\$330.00	\$354.00	\$344	\$369
Child/Senior/Disabled	\$236.00	\$259.00	\$246	\$270
Family	\$661.00	\$708.00	\$689	\$738

2007 Parks Fee Schedule Part 4 of 4 (Page 4 of 4)				
2007 Proposed Aquatics Lesson and Rental Fee Schedule				
Lesson Program	Proposed 2006 Resident Rate	Proposed 2006 Non-Resident Rate	Proposed 2007 Resident Rate	Proposed 2007 Non-Resident Rate
Parent & Tot	\$4.25	\$4.75	\$4.50	\$5.00
Preschool (1-5)	\$4.25	\$4.75	\$4.50	\$5.00
Youth (1&2)	\$4.25	\$4.75	\$4.50	\$5.00
Youth (3-7)	\$4.25	\$4.75	\$4.50	\$5.00
Adult	\$4.25	\$4.75	\$4.50	\$5.00
Water /Fitness-Adults	\$4.25	\$4.75	\$4.50	\$5.00
Water Fitness- Adults10x	\$36.00	\$40.00	\$37.51	\$41.68
Water Fitness Senior	\$3.00	\$3.75	\$3.13	\$3.91
Water Fitness Seniors10x	\$24.00	\$28.00	\$25.00	\$29.18
Arthritis - Adults	\$3.50	\$3.75	\$3.65	\$3.91
Arthritis - Adults 10x	\$35.00	\$37.50	\$36.47	\$39.08
Arthritis-Seniors	\$3.50	\$3.75	\$3.65	\$3.91
Arthritis - Adults 10x	\$35.00	\$37.50	\$36.47	\$39.08
Other Programs				
Swim Day Camp	\$90.00	\$100.00	\$94	\$104
Gators Swim /Dive 7 Wks	\$100.00	\$110.00	\$104	\$115
Rentals				
School Dist: Per 60 Kids/per Hour (non-agreement)	\$30.00	NA	\$31	NA
Rentals On-Going (non-swim team)	\$55.00	NA	\$57	NA
Swim Team Per/ Lane/Hr	\$8.00	NA	\$8	NA
Public Rentals per Hour				
1-60	\$90.00	\$100.00	\$94	\$104
61-150	\$125.00	\$145.00	\$130	\$151

2007 Proposed Surface Water Management Rate Table

Rate Category	Percent Impervious Surface	2006 Annual Service Charge	2007 Annual Service Charge	Per Unit	6% Utility Tax	Fee + Utility Tax
Residential: Single-family home		\$111	\$120	Parcel	\$7.20	\$127.20
Very Light	Less than or equal to 10%	\$111	\$120	Parcel	\$7.20	\$127.20
Light	More than 10%, less than or equal to 20%	\$259	\$280	Acre	\$16.80	\$296.80
Moderate	More than 20%, less than or equal to 45%	\$534	\$577	Acre	\$34.64	\$611.94
Moderately Heavy	More than 45%, less than or equal to 65%	\$1,036	\$1,120	Acre	\$67.20	\$1,187.20
Heavy	More than 65%, less than or equal to 85%	\$1,313	\$1,419	Acre	\$85.17	\$1,504.63
Very Heavy	More than 85%, less than or equal to 100%	\$1,720	\$1,859	Acre	\$111.57	\$1,971.03
Minimum Rate		\$111	\$120		\$7.20	\$127.20
<p>There are two types of service charges: The flat rate and the sliding rate. *The flat rate service charge of \$120 a year applies to single family homes and parcels with less than 10% impervious surface.</p>						
<p>*The sliding rate service charge applies to all other properties in the service area. The sliding rate is calculated by measuring the amount of impervious surface on each parcel and multiplying the appropriate rate by total acreage.</p>						
<p>Several special rate categories will automatically be assigned to those who qualify. *An exemption for any home owned and occupied by a low income senior citizen determined by the assessor to qualify under RCW 84.36.381.</p>						
<p>*A discount for any parcel served by a City approved retention/detention (R/D) facility maintained by the owner.</p>						
<p>*A discount for any parcel, or part parcel officially designated as open space.</p>						
<p>Categories with Retention/Detention Facilities The following categories are eligible for reduced rates if they have an approved retention/detention facility.</p>						
Rate Category	Discount	2006 Annual Service Charge	2007 Annual Service Charge	Per Unit	6% Utility Tax	Fee + Utility Tax
Residential: Single-Family Home	50%	\$55.50	\$60.00	Parcel	\$3.60	\$63.60
Very Light	50%	\$55.50	\$60.00	Parcel	\$3.60	\$63.60
Light	50%	\$111.00	\$140.00	Acre	\$8.40	\$148.40
<p>Alternative Mobile Home Park Charge Mobile Home Park Assessment can be the lower of the appropriate rate category or the number of mobile home spaces multiplied by the single-family residential rate.</p>						
<p>Rate Adjustments: Any person receiving a bill may file a request for a rate adjustment within two years of the billing date. (Filing a request will not extend the payment period) Property owners should file a request for a change in the rate assessed if: acreage is incorrect; *The property is incorrect; *The measured impervious surface should be flat; *The property is charged a sliding fee when the fee</p>						
<p>*The person or property qualifies for an exemption or discount; or</p>						
<p>*The property is wholly or in part outside the service area.</p>						

2007 Proposed Public Records Fee Schedule Page 1 of 1			
Public Records	2006 Fee	Proposed 2007 Fee	Basis
Publications Copied on the Copier - if more than five pages	\$0.15	\$0.15	Per Page
Materials Provided on Computer Diskettes	\$1.50	\$1.50	Per Disk
Publication on CD	\$3.00	\$3.00	Per CD
Video Tapes	\$12.00	\$12.50	Per Tape
Audio Tapes	\$2.00	\$2.00	Per Tape
Photos/Slides	\$2.00 - 21.00	\$2.00 - 21.00	depending on size and
Maps: Tabloid and Letter Size	\$1.50	\$1.50	Per Map
Maps Larger than 11 inches by 17 inches	\$1.50	\$1.50	Per Square Foot
Large Copies (24 inches by 36 inches)	\$3.00	\$3.00	Per Copy
Mylar Sheets	\$5.30	\$5.50	Per Sheet
Clerk Certification	\$1.00	\$1.00	Per Document
Custom GIS Mapping and Data Requests	\$75 Per Hour (1 Hour Minimum)	\$78 Per Hour (1 Hour Minimum)	Per Hour
Financial Fees			
Insufficient funds or a closed account shall be assessed a collection fee	\$25.00	\$26.00	

Object	2006 Adopted Budget	2006 Current Budget	2006 YTD Actuals	2006 Current Year Est.	2007 Dept Request	2007 Service Package	2007 Proposed Budget	2007 Base Budget	2007 Final Budget	Change in Budget	Pct Chg
Department 10 City Council											
<i>Revenue Accounts</i>											
3131000 - Local Sales & Use Taxes	0	0	0	0	0	0	0	0	0	0.00	0.00
3360695 - Liquor Board Profits	0	0	0	0	0	0	0	0	0	0.00	0.00
3614000 - Interest-Cont,Note,Loan,A/R	0	0	0	0	0	0	0	0	0	0.00	0.00
Total Revenue Accounts:	0	0	0	0	0	0	0	0	0	0.00	0.00
Department 11 City Manager											
<i>Revenue Accounts</i>											
3339701 - FEMA INDIRECT WA ST MIL DEI	0	0	0	24,123	0	0	0	0	0	0.00	0.00
Total Revenue Accounts:	0	0	0	24,123	0	0	0	0	0	0.00	0.00
Department 12 City Clerk											
<i>Revenue Accounts</i>											
3216000 - Buss Lic-Professional/Occuptnl	24,480	24,480	2,699	24,480	24,480	0	24,480	24,480	24,480	0.00	0.00
3216001 - Buss Lic-Adult Entertainers	0	0	10,086	0	0	0	0	0	0	0.00	0.00
3216002 - Buss Lic-Second Hand Dealers	0	0	120	0	0	0	0	0	0	0.00	0.00
3218000 - Buss Lic - Penalties	50	50	8	0	50	0	50	50	50	0.00	0.00
3415200 - Franchise Reimbursements-cable	0	0	3,767	3,767	3,767	0	3,767	0	3,767	3,767.00	0.00
3458900 - Hearing Examiner Appeal Fee	1,520	1,520	0	0	1,600	0	1,600	1,520	1,600	80.00	5.26
Total Revenue Accounts:	26,050	26,050	16,680	28,247	29,897	0	29,897	26,050	29,897	3,847.00	14.76
Department 13 Community/Government Rel											
<i>Revenue Accounts</i>											
3699000 - Miscellaneous Revenue	0	0	20	20	0	0	0	0	0	0.00	0.00
Total Revenue Accounts:	0	0	20	20	0	0	0	0	0	0.00	0.00
Department 14 Human Services											
<i>Revenue Accounts</i>											
3331000 - CDBG Grant Allocation	84,724	84,724	40,704	81,407	87,653	0	87,653	84,724	87,653	2,929.00	3.45
3332000 - CDBG Grant Administration	40,658	40,658	19,376	41,407	37,653	0	37,653	40,658	37,653	-3,005.00	-7.39
3360626 - Criminal Justice-Special Prgms	14,569	14,569	10,896	14,569	14,856	0	14,856	14,569	14,856	287.00	1.96
3360694 - Liquor Excise Tax	4,127	4,127	3,218	4,127	4,127	0	4,127	4,127	4,127	0.00	0.00
3360695 - Liquor Board Profits	7,781	7,781	5,101	7,080	7,781	0	7,781	7,781	7,781	0.00	0.00
Total Revenue Accounts:	151,859	151,859	79,295	148,590	152,070	0	152,070	151,859	152,070	211.00	0.13
Department 16 Finance											
<i>Revenue Accounts</i>											
3414300 - Financial/Accounting Services	1,800	1,800	1,350	1,800	1,800	0	1,800	1,800	1,800	0.00	0.00
3698100 - Misc-Cash Over/Short	0	0	0	0	0	0	0	0	0	0.00	0.00
3699000 - Miscellaneous Revenue	0	0	6,366	6,367	5,000	0	5,000	5,000	5,000	5,000.00	0.00
Total Revenue Accounts:	1,800	1,800	7,716	8,167	6,800	0	6,800	6,800	6,800	5,000.00	277.77
Department 17 City Wide											

City of Shoreline - 2007 Proposed Budget

Comparative Budget Worksheet By Object

APPENDIX

Object	2006 Adopted Budget	2006 Current Budget	2006 YTD Actuals	2006 Current Year Est.	2007 Dept Request	2007 Service Package	2007 Proposed Budget	2007 Base Budget	2007 Final Budget	Change in Budget	Pct Chg
<i>Revenue Accounts</i>											
3080000 - Budgeted Begining Fund Balance	1,993,581	2,140,529	0	0	505,000	146,500	651,500	652,729	651,500	-1,489,029.00	-69.56
3111000 - Property Tax	6,935,415	6,935,415	3,699,689	6,935,415	7,066,510	0	7,066,510	6,935,415	7,066,510	131,095.00	1.89
3131000 - Local Sales & Use Taxes	5,785,500	5,785,500	4,016,315	6,086,402	6,250,000	0	6,250,000	5,785,500	6,250,000	464,500.00	8.02
3164300 - Private Utility, Tax-Gas	850,000	850,000	639,486	850,000	1,045,000	0	1,045,000	850,000	1,045,000	195,000.00	22.94
3164500 - Private Utility, Tax-Garbage	331,000	331,000	220,620	331,000	340,000	0	340,000	331,000	340,000	9,000.00	2.71
3164600 - Private Utility, Tax-Cable	96,000	96,000	57,161	96,000	98,000	0	98,000	96,000	98,000	2,000.00	2.08
3164701 - Priv Util Tax-Tele,Cell,Pager	1,480,000	1,480,000	1,002,548	1,480,000	1,555,000	0	1,555,000	1,480,000	1,555,000	75,000.00	5.06
3167800 - Utility Tax-Storm Drainage	162,500	162,500	86,165	162,500	177,000	0	177,000	162,500	177,000	14,500.00	8.92
3172000 - Leasehold Excise Tax	2,500	2,500	0	2,500	0	0	0	2,500	0	-2,500.00	-100.00
3172001 - City Leasehold Excise Tax	1,000	1,000	560	1,000	672	0	672	1,000	672	-328.00	-32.80
3175100 - Punch Boards/Pull Tabs	236,000	236,000	68,801	185,000	185,000	0	185,000	236,000	185,000	-51,000.00	-21.61
3175200 - Bingo/Raffles	44,000	44,000	12,454	18,300	0	0	0	44,000	0	-44,000.00	-100.00
3175300 - Amusement Games	500	500	7,777	500	500	0	500	500	500	0.00	0.00
3175400 - Card Games	2,650,000	2,650,000	1,063,628	1,850,000	1,949,000	0	1,949,000	2,650,000	1,949,000	-701,000.00	-26.45
3219001 - Business Registration	0	0	0	0	90,000	0	90,000	0	90,000	90,000.00	0.00
3219101 - Franchise Fee - Cable	480,000	480,000	263,098	526,000	530,000	0	530,000	480,000	530,000	50,000.00	10.41
3219102 - Franchise Fee - Electric	850,000	850,000	0	0	0	0	0	850,000	0	-850,000.00	-100.00
3219103 - Franchise Fee - Water	500,000	500,000	295,162	610,000	565,000	0	565,000	500,000	565,000	65,000.00	13.00
3219104 - Franchise Fee - Sewage	636,500	636,500	477,750	636,500	655,595	0	655,595	636,500	655,595	19,095.00	3.00
3223000 - Animal Licenses	200	200	1	200	200	0	200	200	200	0.00	0.00
3360694 - Liquor Excise Tax	202,199	202,199	157,702	202,199	221,072	0	221,072	202,199	221,072	18,873.00	9.33
3360695 - Liquor Board Profits	381,245	381,245	249,945	346,934	385,195	0	385,195	381,245	385,195	3,950.00	1.03
3377100 - City of Seattle-City Light Cont	0	0	719,918	1,000,000	1,000,000	0	1,000,000	0	1,000,000	1,000,000.00	0.00
3415100 - Sales/Svc Non-Taxable	0	0	3,329	1,344	0	0	0	0	0	0.00	0.00
3611100 - Investment Interest	300,000	300,000	135,090	171,000	375,000	0	375,000	300,000	375,000	75,000.00	25.00
3611110 - LGIP Investment Interest	0	0	85,361	129,000	0	0	0	0	0	0.00	0.00
3614000 - Interest-Cont,Note,Loan,A/R	20,000	20,000	16,944	20,000	20,000	0	20,000	20,000	20,000	0.00	0.00
3628002 - Vend Machine Proceeds-Non Tax	0	0	76	66	0	0	0	0	0	0.00	0.00
3691100 - Misc Revenue-Recycle Proceeds	0	0	0	0	0	0	0	0	0	0.00	0.00
3699000 - Miscellaneous Revenue	30,000	30,000	-817	45	15,000	0	15,000	30,000	15,000	-15,000.00	-50.00
3699001 - Misc Rev-Recovery of NSF Fees	0	0	175	150	0	0	0	0	0	0.00	0.00
3970000 - Operating Transfers In	1,203,841	1,203,841	601,921	1,203,841	1,046,447	0	1,046,447	1,203,841	1,046,447	-157,394.00	-13.07
Total Revenue Accounts:	25,171,981	25,318,929	13,880,859	22,845,896	24,075,191	146,500	24,221,691	23,831,129	24,221,691	-1,097,238.00	-4.33
Department 18 Human Resources											
<i>Revenue Accounts</i>											
3671100 - Grants/Pldges frm Priv Sources	1,000	1,000	0	1,000	1,500	0	1,500	1,000	1,500	500.00	50.00
3699002 - Misc. Rev. Flex-Plan Forfeits	0	0	1,031	1,031	0	0	0	0	0	0.00	0.00
Total Revenue Accounts:	1,000	1,000	1,031	2,031	1,500	0	1,500	1,000	1,500	500.00	50.00
Department 20 Police											

Object	2006 Adopted Budget	2006 Current Budget	2006 YTD Actuals	2006 Current Year Est.	2007 Dept Request	2007 Service Package	2007 Proposed Budget	2007 Base Budget	2007 Final Budget	Change in Budget	Pct Chg
<i>Revenue Accounts</i>											
3137100 - Local Criminal Justice Funding	1,100,687	1,100,687	884,712	1,150,687	1,224,500	0	1,224,500	1,100,687	1,224,500	123,813.00	11.24
3311658 - DOJ-Byrne Memorial Grant Prog.	0	0	11,883	11,883	0	0	0	0	0	0.00	0.00
3332061 - Natl Hwy Traffic Safety Grant	0	0	0	0	0	0	0	0	0	0.00	0.00
3339704 - USD Homeland Sec - Through K.C	0	0	7,877	7,877	0	0	0	0	0	0.00	0.00
3340351 - Traffic Safety Commission	29,400	29,400	7,885	8,320	29,400	0	29,400	29,400	29,400	0.00	0.00
3340691 - WA Assoc Sheriffs/Police Chief	2,500	2,500	0	0	2,500	0	2,500	2,500	2,500	0.00	0.00
3360621 - MVET - Violent Crime	11,550	11,550	7,447	7,447	11,663	0	11,663	11,550	11,663	113.00	0.97
3360625 - MVET - CJ Contracted Service	65,155	65,155	50,866	65,155	65,155	0	65,155	65,155	65,155	0.00	0.00
3360626 - Criminal Justice-Special Prgms	10,238	10,238	7,657	7,657	10,439	0	10,439	10,238	10,439	201.00	1.96
3360651 - DUI/Other Criminal Just Assist	9,160	9,160	6,547	6,547	9,160	0	9,160	9,160	9,160	0.00	0.00
3371000 - Interlocal Funding - General	0	0	43,063	43,063	0	0	0	0	0	0.00	0.00
3379000 - Interlocal Government-Other	92,975	92,975	0	0	32,000	0	32,000	92,975	32,000	-60,975.00	-65.58
3429000 - Kenmore - Jail Van Svc. Charge	0	0	287	287	0	0	0	0	0	0.00	0.00
3531000 - Traffic Infraction Refund	0	0	4,265	2,901	0	0	0	0	0	0.00	0.00
3599001 - Fines/Penalties-Code Violation	10,000	10,000	8,925	10,000	10,000	0	10,000	10,000	10,000	0.00	0.00
3699000 - Miscellaneous Revenue	0	0	0	1,290	1,290	0	1,290	0	1,290	1,290.00	0.00
Total Revenue Accounts:	1,331,665	1,331,665	1,041,414	1,323,114	1,396,107	0	1,396,107	1,331,665	1,396,107	64,442.00	4.83
Department 21 Criminal Justice											
<i>Revenue Accounts</i>											
3572300 - Public Defense Cost Reimbursmt	1,000	1,000	0	0	0	0	0	0	0	-1,000.00	-100.00
Total Revenue Accounts:	1,000	1,000	0	0	0	0	0	0	0	-1,000.00	-100.00
Department 24 Parks, Recreation, Cultural S											
<i>Revenue Accounts</i>											
3219000 - Concession Permits	8,800	8,800	125	200	8,800	0	8,800	8,800	8,800	0.00	0.00
3340460 - DSHS Grant-Adult Choices	4,500	4,500	3,741	4,500	7,482	0	7,482	4,500	7,482	2,982.00	66.26
3360626 - Criminal Justice-Special Prgms	14,569	14,569	10,896	14,569	14,856	0	14,856	14,569	14,856	287.00	1.96
3371500 - KC - Community Organizing Prg	0	0	1,529	1,530	1,000	0	1,000	0	1,000	1,000.00	0.00
3379000 - Interlocal Government-Other	10,000	10,000	0	0	10,000	0	10,000	10,000	10,000	0.00	0.00
3379001 - LFP Teen Participation	0	0	7,500	10,000	0	0	0	0	0	0.00	0.00
3387401 - LFP Residential Discount	0	0	1,430	5,734	5,000	0	5,000	0	5,000	5,000.00	0.00
3387402 - LFP Scholarship Program	0	0	100	2,000	2,000	0	2,000	0	2,000	2,000.00	0.00
3415100 - Sales/Svc Non-Taxable	0	0	50	50	0	0	0	0	0	0.00	0.00
3473000 - Teen Trips	8,800	8,800	6,323	8,800	8,100	0	8,100	8,800	8,100	-700.00	-7.95
3473001 - Teen Classes	4,800	4,800	2,333	4,800	4,000	0	4,000	4,800	4,000	-800.00	-16.66
3473101 - Activity Fees-Lessons	159,000	159,000	155,585	170,000	170,000	0	170,000	159,000	170,000	11,000.00	6.91
3473102 - Activity Fees-Fitness Classes	19,000	19,000	17,997	21,000	22,000	0	22,000	19,000	22,000	3,000.00	15.78
3473103 - Activity Fees-Arthritis Progrm	13,507	13,507	9,065	10,500	11,900	0	11,900	13,507	11,900	-1,607.00	-11.89
3473104 - Activ Fee-Admisns/Drop In Txbl	113,700	113,700	101,678	121,500	124,700	0	124,700	113,700	124,700	11,000.00	9.67
3473105 - Activity Fee-One Time Rnt Txbl	55,900	55,900	38,097	55,900	50,500	0	50,500	55,900	50,500	-5,400.00	-9.66

City of Shoreline - 2007 Proposed Budget

Comparative Budget Worksheet By Object

APPENDIX

Object	2006 Adopted Budget	2006 Current Budget	2006 YTD Actuals	2006 Current Year Est.	2007 Dept Request	2007 Service Package	2007 Proposed Budget	2007 Base Budget	2007 Final Budget	Change in Budget	Pct Chg
3473107 - Activity Fee-Locker Fees	2,750	2,750	2,303	2,900	2,750	0	2,750	2,750	2,750	0.00	0.00
3473111 - Activity Fee-Water Sfty Course	6,500	6,500	4,983	6,500	6,500	0	6,500	6,500	6,500	0.00	0.00
3473200 - Athletic Field Rental - All	0	0	119,476	147,000	0	0	0	0	0	0.00	0.00
3473201 - Athletic Field Rental-Youth	62,485	62,485	1,088	2,000	68,010	0	68,010	62,485	68,010	5,525.00	8.84
3473202 - Athletic Field Rental-Adult	79,690	79,690	0	0	95,690	0	95,690	79,690	95,690	16,000.00	20.07
3473204 - Rec Center Rental	55,500	55,500	15,728	26,000	55,500	0	55,500	55,500	55,500	0.00	0.00
3473205 - Pic Nic Shelter Rental	7,000	7,000	8,647	10,500	7,000	0	7,000	7,000	7,000	0.00	0.00
3473206 - Spartan Gym Rental	0	0	28,802	29,000	0	0	0	0	0	0.00	0.00
3476220 - Preschool-Sports Skills	10,300	10,300	23,271	25,000	24,000	0	24,000	10,300	24,000	13,700.00	133.00
3476221 - Preschool-Arts	15,000	15,000	9,004	10,000	15,000	0	15,000	15,000	15,000	0.00	0.00
3476222 - Preschool-Indoor Playground	10,000	10,000	7,475	11,000	10,000	0	10,000	10,000	10,000	0.00	0.00
3476329 - Youth-Summer Playground	38,300	38,300	70,539	75,000	70,000	0	70,000	38,300	70,000	31,700.00	82.76
3476331 - Youth-Arts	20,000	20,000	26,522	25,900	26,000	0	26,000	20,000	26,000	6,000.00	30.00
3476336 - Youth-Special Interest	3,000	3,000	18,160	18,210	31,500	0	31,500	3,000	31,500	28,500.00	950.00
3476337 - Youth-Skyhawk Program	40,200	40,200	47,261	50,000	48,000	0	48,000	40,200	48,000	7,800.00	19.40
3476339 - Youth-Sports Skills	48,500	48,500	38,691	40,200	48,500	0	48,500	48,500	48,500	0.00	0.00
3476340 - Youth-Health & Fitness	3,000	3,000	6,784	6,000	18,000	0	18,000	3,000	18,000	15,000.00	500.00
3476440 - Adult-Drop In Sports	10,600	10,600	0	0	10,600	0	10,600	10,600	10,600	0.00	0.00
3476441 - Adult-Arts	12,000	12,000	14,986	16,000	17,500	0	17,500	12,000	17,500	5,500.00	45.83
3476442 - Adult-Sports Leagues	50,800	50,800	44,019	48,000	50,800	0	50,800	50,800	50,800	0.00	0.00
3476444 - Adult-Special Interest	4,500	4,500	954	1,000	4,500	0	4,500	4,500	4,500	0.00	0.00
3476446 - Adult-Health/Fitness	27,000	27,000	63,073	62,000	71,000	0	71,000	27,000	71,000	44,000.00	162.96
3476447 - Adult-Dog Obedience	12,000	12,000	12,697	14,000	12,000	0	12,000	12,000	12,000	0.00	0.00
3476555 - Special Rec-Trips	0	0	1,114	1,000	0	0	0	0	0	0.00	0.00
3476558 - Special Rec-Classes	25,300	25,300	31,925	34,000	25,300	0	25,300	25,300	25,300	0.00	0.00
3476665 - City Wide-Celebrate Shoreline	9,000	9,000	6,729	9,000	19,000	0	19,000	9,000	19,000	10,000.00	111.11
3476999 - Shoreline Scholarship Clearing	0	0	-31,095	-32,255	-32,000	0	-32,000	0	-32,000	-32,000.00	0.00
3626000 - Rental Income-Caretaker House	7,056	7,056	6,262	7,056	7,056	0	7,056	7,056	7,056	0.00	0.00
3628002 - Vend Machine Proceeds-Non Tax	3,090	3,090	2,299	3,516	3,800	0	3,800	3,090	3,800	710.00	22.97
3628003 - Merchandise Sales	3,750	3,750	4,758	5,000	5,500	0	5,500	3,750	5,500	1,750.00	46.66
3629001 - Use of Property - Cell Tower	24,000	24,000	31,534	37,474	37,000	0	37,000	24,000	37,000	13,000.00	54.16
3670100 - Donate From Priv Sourc-General	0	0	4,100	3,599	0	0	0	0	0	0.00	0.00
3671100 - Grants/Pldges frm Priv Sources	0	0	500	500	500	0	500	0	500	500.00	0.00
3672200 - Donate From Priv Src-Memorial	1,620	1,620	0	1,620	1,620	0	1,620	1,620	1,620	0.00	0.00
3698100 - Misc-Cash Over/Short	0	0	-17	2	0	0	0	0	0	0.00	0.00
3699000 - Miscellaneous Revenue	6,000	6,000	910	1,000	3,000	0	3,000	6,000	3,000	-3,000.00	-50.00
Total Revenue Accounts:	1,011,517	1,011,517	979,931	1,128,805	1,203,964	0	1,203,964	1,011,517	1,203,964	192,447.00	19.02
Department 25 Planning & Development Sv											
<i>Revenue Accounts</i>											
3221011 - Permits-Building & Structures	439,000	439,000	371,063	452,170	455,000	0	455,000	439,000	455,000	16,000.00	3.64

Object	2006 Adopted Budget	2006 Current Budget	2006 YTD Actuals	2006 Current Year Est.	2007 Dept Request	2007 Service Package	2007 Proposed Budget	2007 Base Budget	2007 Final Budget	Change in Budget	Pct Chg
3221012 - Permits, Bldg/Struct- Plumbing	7,000	7,000	635	1,310	1,300	0	1,300	7,000	1,300	-5,700.00	-81.42
3221013 - Permits,Bldg/Struct-Electrical	29,635	29,635	2,346	12,348	29,635	0	29,635	29,635	29,635	0.00	0.00
3221131 - Mechanical Fees/Permits	60,000	85,000	50,932	65,724	65,000	0	65,000	60,000	65,000	-20,000.00	-23.52
3221241 - Land Use Fees/Permits	215,000	215,000	211,675	236,500	230,000	0	230,000	215,000	230,000	15,000.00	6.97
3221501 - Fire System Fees/Permits	13,000	13,000	9,603	13,390	13,400	0	13,400	13,000	13,400	400.00	3.07
3415000 - Sales/Services-Taxable	0	0	333	368	0	0	0	0	0	0.00	0.00
3415100 - Sales/Svc Non-Taxable	0	0	1,974	1,653	0	0	0	0	0	0.00	0.00
3424011 - Inspection Service-Plumbing	70,000	70,000	82,673	78,000	78,000	0	78,000	70,000	78,000	8,000.00	11.42
3458311 - Plan Check Fees	285,000	420,000	283,696	393,550	395,000	0	395,000	285,000	395,000	-25,000.00	-5.95
3458991 - Environmental Review(SEPA/EIS)	25,000	25,000	15,150	25,750	25,000	0	25,000	25,000	25,000	0.00	0.00
3698100 - Misc-Cash Over/Short	0	0	1	0	0	0	0	0	0	0.00	0.00
Total Revenue Accounts:	1,143,635	1,303,635	1,030,081	1,280,763	1,292,335	0	1,292,335	1,143,635	1,292,335	-11,300.00	-0.86
Department 26 Economic Development											
<i>Revenue Accounts</i>											
3219001 - Business Registration	95,000	95,000	0	0	0	0	0	95,000	0	-95,000.00	-100.00
Total Revenue Accounts:	95,000	95,000	0	0	0	0	0	95,000	0	-95,000.00	-100.00
Department 27 Public Works											
<i>Revenue Accounts</i>											
3340311 - DOE -CPG Grant	36,106	36,106	0	53,892	0	0	0	0	0	-36,106.00	-100.00
3372101 - KC Recyl-Cty Opt Pgm (COP/WRR)	42,541	42,541	0	42,541	42,541	0	42,541	42,541	42,541	0.00	0.00
3372102 - KC Lcl Haz Wst Mgmt Pgm(LHWM)	22,383	22,383	0	22,383	24,087	0	24,087	24,124	24,087	1,704.00	7.61
3379000 - Interlocal Government-Other	0	0	63,750	63,750	0	0	0	0	0	0.00	0.00
3415100 - Sales/Svc Non-Taxable	0	0	40	15	0	0	0	0	0	0.00	0.00
3691100 - Misc Revenue-Recycle Proceeds	54,680	54,680	54,278	54,278	55,988	0	55,988	55,988	55,988	1,308.00	2.39
Total Revenue Accounts:	155,710	155,710	118,068	236,859	122,616	0	122,616	122,653	122,616	-33,094.00	-21.25
Total General Fund:	29,091,217	29,398,165	17,155,095	27,026,615	28,280,480	146,500	28,426,980	27,721,308	28,426,980	-971,185.00	-3.30
Department 27 Public Works											
<i>Revenue Accounts</i>											
3080000 - Budgeted Begining Fund Balance	0	89,774	0	0	0	120,000	120,000	0	120,000	30,226.00	33.66
3224001 - Right of Way Fees/Permits	111,469	111,469	104,856	111,469	120,000	0	120,000	111,469	120,000	8,531.00	7.65
3360087 - MV Fuel Tax-City Streets	771,277	771,277	548,229	763,789	746,966	0	746,966	771,277	746,966	-24,311.00	-3.15
3575100 - Superior Court Restitution	0	0	11	11	0	0	0	0	0	0.00	0.00
3611100 - Investment Interest	22,000	22,000	9,793	15,471	35,000	0	35,000	22,000	35,000	13,000.00	59.09
3611110 - LGIP Investment Interest	0	0	8,190	12,285	0	0	0	0	0	0.00	0.00
3699000 - Miscellaneous Revenue	0	0	44,599	44,598	0	0	0	0	0	0.00	0.00
3952000 - Comp. Loss of Assets-Ins. Recr	0	0	17,476	17,476	0	0	0	0	0	0.00	0.00
3970000 - Operating Transfers In	1,565,131	1,565,131	782,566	1,565,131	1,444,782	-44,661	1,400,121	1,565,131	1,400,121	-165,010.00	-10.54
Total Revenue Accounts:	2,469,877	2,559,651	1,515,720	2,530,230	2,346,748	75,339	2,422,087	2,469,877	2,422,087	-137,564.00	-5.37
Total Street Fund:	2,469,877	2,559,651	1,515,720	2,530,230	2,346,748	75,339	2,422,087	2,469,877	2,422,087	-137,564.00	-5.37

Object	2006 Adopted Budget	2006 Current Budget	2006 YTD Actuals	2006 Current Year Est.	2007 Dept Request	2007 Service Package	2007 Proposed Budget	2007 Base Budget	2007 Final Budget	Change in Budget	Pct Chg
Department 99 Not Applicable											
<i>Revenue Accounts</i>											
3360087 - MV Fuel Tax-City Streets	0	0	-37,250	0	0	0	0	0	0	0.00	0.00
3360088 - MV Fuel Tax-Arterial Streets	0	0	37,250	0	0	0	0	0	0	0.00	0.00
3611100 - Investment Interest	0	0	40	0	0	0	0	0	0	0.00	0.00
3611110 - LGIP Investment Interest	0	0	783	0	0	0	0	0	0	0.00	0.00
Total Revenue Accounts:	0	0	823	0	0	0	0	0	0	0.00	0.00
Total Arterial Street Fund:	0	0	823	0	0	0	0	0	0	0.00	0.00
Department 99 Not Applicable											
<i>Revenue Accounts</i>											
3611100 - Investment Interest	0	0	47,470	68,850	58,546	0	58,546	0	58,546	58,546.00	0.00
3611110 - LGIP Investment Interest	0	0	10,067	15,101	0	0	0	0	0	0.00	0.00
3970000 - Operating Transfers In	38,350	38,350	19,175	38,350	0	0	0	38,350	0	-38,350.00	-100.00
Total Revenue Accounts:	38,350	38,350	76,712	122,301	58,546	0	58,546	38,350	58,546	20,196.00	52.66
Total General Reserve Fund:	38,350	38,350	76,712	122,301	58,546	0	58,546	38,350	58,546	20,196.00	52.66
Department 25 Planning & Development Sv											
<i>Revenue Accounts</i>											
3221011 - Permits-Building & Structures	0	0	0	0	0	0	0	0	0	0.00	0.00
3458311 - Plan Check Fees	0	0	0	0	0	0	0	0	0	0.00	0.00
3611100 - Investment Interest	0	0	0	0	0	0	0	0	0	0.00	0.00
Total Revenue Accounts:	0	0	0	0	0	0	0	0	0	0.00	0.00
Total Development Services Fund:	0	0	0	0	0	0	0	0	0	0.00	0.00
Department 25 Planning & Development Sv											
<i>Revenue Accounts</i>											
3080000 - Budgeted Begining Fund Balance	0	0	0	0	17,500	0	17,500	0	17,500	17,500.00	0.00
3599001 - Fines/Penalties-Code Violation	0	0	21,250	21,250	0	0	0	0	0	0.00	0.00
3611100 - Investment Interest	2,500	2,500	1,664	2,563	2,500	0	2,500	2,500	2,500	0.00	0.00
3611110 - LGIP Investment Interest	0	0	2,036	3,490	0	0	0	0	0	0.00	0.00
3614000 - Interest-Cont,Note,Loan,A/R	0	0	1,159	1,159	0	0	0	0	0	0.00	0.00
3694001 - Judgement/Settle-Abatemnt Coll	80,000	80,000	750	750	80,000	0	80,000	80,000	80,000	0.00	0.00
3970000 - Operating Transfers In	20,000	20,000	10,000	20,000	0	0	0	20,000	0	-20,000.00	-100.00
Total Revenue Accounts:	102,500	102,500	36,859	49,212	100,000	0	100,000	102,500	100,000	-2,500.00	-2.43
Total Code Abatement Fund:	102,500	102,500	36,859	49,212	100,000	0	100,000	102,500	100,000	-2,500.00	-2.43
Department 20 Police											
<i>Revenue Accounts</i>											
3611100 - Investment Interest	500	500	381	512	500	0	500	500	500	0.00	0.00
3611110 - LGIP Investment Interest	0	0	194	291	0	0	0	0	0	0.00	0.00
3693000 - State Asset Seizure Funds	8,000	8,000	1,874	8,000	8,000	0	8,000	8,000	8,000	0.00	0.00

Object	2006 Adopted Budget	2006 Current Budget	2006 YTD Actuals	2006 Current Year Est.	2007 Dept Request	2007 Service Package	2007 Proposed Budget	2007 Base Budget	2007 Final Budget	Change in Budget	Pct Chg
3693300 - Federal Asset Seizure Funds	15,000	15,000	0	10,000	15,000	0	15,000	15,000	15,000	0.00	0.00
Total Revenue Accounts:	23,500	23,500	2,449	18,803	23,500	0	23,500	23,500	23,500	0.00	0.00
Total Asset Seizure Fund:	23,500	23,500	2,449	18,803	23,500	0	23,500	23,500	23,500	0.00	0.00
Department 24 Parks, Recreation, Cultural S											
<i>Revenue Accounts</i>											
3080000 - Budgeted Begining Fund Balance	0	115,775	0	0	0	0	0	0	0	-115,775.00	-100.00
3611100 - Investment Interest	0	0	2,852	4,214	0	0	0	0	0	0.00	0.00
3611110 - LGIP Investment Interest	0	0	7,361	11,042	0	0	0	0	0	0.00	0.00
3970000 - Operating Transfers In	33,892	33,892	0	33,892	0	0	0	0	0	-33,892.00	-100.00
Total Revenue Accounts:	33,892	149,667	10,213	49,148	0	0	0	0	0	-149,667.00	-100.00
Total Public Arts Fund:	33,892	149,667	10,213	49,148	0	0	0	0	0	-149,667.00	-100.00
Department 28 General Government CIP											
<i>Revenue Accounts</i>											
3080000 - Budgeted Begining Fund Balance	545,671	5,843,201	0	0	8,760,643	0	8,760,643	545,671	8,760,643	2,917,442.00	49.92
3173400 - REET-1st Quarter	712,674	712,674	818,934	850,000	355,000	0	355,000	712,674	355,000	-357,674.00	-50.18
3340231 - State Grants-Dept Natrl Resour	0	0	0	0	300,000	0	300,000	0	300,000	300,000.00	0.00
3371000 - Interlocal Funding - General	0	0	0	0	400,000	0	400,000	0	400,000	400,000.00	0.00
3378200 - K.C.- Conservation Levy Fundng	1,000,000	1,000,000	0	900,000	79,025	0	79,025	1,000,000	79,025	-920,975.00	-92.09
3379000 - Interlocal Government-Other	700,000	700,000	0	75,000	0	0	0	700,000	0	-700,000.00	-100.00
3611100 - Investment Interest	225,847	225,847	150,285	217,810	685,555	0	685,555	225,847	685,555	459,708.00	203.54
3611110 - LGIP Investment Interest	0	0	176,678	266,213	0	0	0	0	0	0.00	0.00
3670100 - Donate From Priv Sourc-General	0	0	140,000	200,000	0	0	0	0	0	0.00	0.00
3671100 - Grants/Pldges frm Priv Sources	200,000	200,000	60,000	0	0	0	0	200,000	0	-200,000.00	-100.00
3911001 - Gen Obligation Bond Proceeds	9,800,000	9,800,000	0	18,500,000	12,750,000	0	12,750,000	9,800,000	12,750,000	2,950,000.00	30.10
3970000 - Operating Transfers In	544,738	544,738	544,738	2,069,738	361,000	0	361,000	544,738	361,000	-183,738.00	-33.72
Total Revenue Accounts:	13,728,930	19,026,460	1,890,635	23,078,761	23,691,223	0	23,691,223	13,728,930	23,691,223	4,664,763.00	24.51
Total Capital Improvement Fund:	13,728,930	19,026,460	1,890,635	23,078,761	23,691,223	0	23,691,223	13,728,930	23,691,223	4,664,763.00	24.51
Department 31 Facility Major Maintenance }											
<i>Revenue Accounts</i>											
3080000 - Budgeted Begining Fund Balance	0	0	0	0	32,028	0	32,028	0	32,028	32,028.00	0.00
3611100 - Investment Interest	4,680	4,680	1,512	2,000	7,972	0	7,972	4,680	7,972	3,292.00	70.34
3611110 - LGIP Investment Interest	0	0	3,308	4,429	0	0	0	0	0	0.00	0.00
3970000 - Operating Transfers In	70,000	70,000	70,000	70,000	70,000	0	70,000	70,000	70,000	0.00	0.00
Total Revenue Accounts:	74,680	74,680	74,820	76,429	110,000	0	110,000	74,680	110,000	35,320.00	47.29
Total City Facility-Major Maint Fund:	74,680	74,680	74,820	76,429	110,000	0	110,000	74,680	110,000	35,320.00	47.29
Department 29 Roads Capital Improvements											
<i>Revenue Accounts</i>											
3080000 - Budgeted Begining Fund Balance	3,926,525	6,777,129	0	0	1,349,929	0	1,349,929	3,926,525	1,349,929	-5,427,200.00	-80.08

Object	2006 Adopted Budget	2006 Current Budget	2006 YTD Actuals	2006 Current Year Est.	2007 Dept Request	2007 Service Package	2007 Proposed Budget	2007 Base Budget	2007 Final Budget	Change in Budget	Pct Chg
3173400 - REET-1st Quarter	0	0	0	25,000	45,000	0	45,000	0	45,000	45,000.00	0.00
3173500 - REET-2nd Quarter	712,674	712,674	818,934	1,075,000	825,000	0	825,000	712,674	825,000	112,326.00	15.76
3224500 - Residentil Parking Zone Permit	0	0	315	105	0	0	0	0	0	0.00	0.00
3311000 - TEA 21-Federal Direct	0	90,000	0	90,000	0	0	0	0	0	-90,000.00	-100.00
3330100 - Federal Indirect-General	3,343,224	4,153,224	0	5,026,078	3,389,000	0	3,389,000	3,343,224	3,389,000	-764,224.00	-18.40
3331000 - CDBG Grant Allocation	114,499	166,042	31,960	166,042	0	0	0	114,499	0	-166,042.00	-100.00
3332021 - Hazard Elimination System Grnt	0	0	20,470	21,432	0	0	0	0	0	0.00	0.00
3332057 - Cong Mitigation & Air Quality	1,078,060	1,078,060	0	1,078,060	0	0	0	1,078,060	0	-1,078,060.00	-100.00
3332058 - Surface Transp Program - Urban	1,884,889	4,086,984	1,076,038	2,324,944	0	0	0	1,884,889	0	-4,086,984.00	-100.00
3340231 - State Grants-Dept Natrl Resour	2,397,898	2,397,898	718,017	2,242,008	0	0	0	2,397,898	0	-2,397,898.00	-100.00
3340365 - WSDOT - State Grant - TIB	300,000	300,000	0	135,200	50,000	0	50,000	300,000	50,000	-250,000.00	-83.33
3340366 - WSDOT-General Funding	4,380,627	4,380,627	4,772,918	5,410,238	0	0	0	4,380,627	0	-4,380,627.00	-100.00
3340382 - Trans. Imp. Brd. Aurora 145th	2,858,007	3,681,795	2,085,720	3,681,795	0	0	0	2,858,007	0	-3,681,795.00	-100.00
3340692 - Hazard Elimination Syst (HES)	0	91,951	0	72,000	0	0	0	0	0	-91,951.00	-100.00
3360087 - MV Fuel Tax-City Streets	0	0	335,930	360,425	0	0	0	0	0	0.00	0.00
3360088 - MV Fuel Tax-Arterial Streets	472,448	472,448	0	167,759	591,312	0	591,312	472,448	591,312	118,864.00	25.15
3371000 - Interlocal Funding - General	379,518	379,518	0	0	0	0	0	379,518	0	-379,518.00	-100.00
3371010 - Ir terlocal Funding - SCL	2,701,656	2,847,478	1,658,859	3,118,390	0	0	0	2,701,656	0	-2,847,478.00	-100.00
3371020 - Interlocal Funding - SPU	7,398	7,398	33,515	517,037	0	0	0	7,398	0	-7,398.00	-100.00
3371040 - Interlocal Funding-SWD	0	6,000	6,000	6,395	0	0	0	0	0	-6,000.00	-100.00
3373101 - King County Parks Grant	25,000	25,000	0	129,533	0	0	0	25,000	0	-25,000.00	-100.00
3378000 - King County - METRO	375,000	375,000	0	375,000	0	0	0	375,000	0	-375,000.00	-100.00
3458110 - Ir-Lieu Payment	0	0	0	83,615	20,000	0	20,000	0	20,000	20,000.00	0.00
3611100 - Ir-vestment Interest	388,875	388,875	77,028	523,658	350,191	0	350,191	388,875	350,191	-38,684.00	-9.94
3611110 - LGIP Investment Interest	0	0	78,140	0	0	0	0	0	0	0.00	0.00
3671100 - Grants/Pldges frm Priv Sources	200,000	200,000	0	100,556	0	0	0	200,000	0	-200,000.00	-100.00
3699000 - Miscellaneous Revenue	0	0	2	0	0	0	0	0	0	0.00	0.00
3970000 - Operating Transfers In	1,870,817	1,870,817	664,934	1,391,270	613,002	0	613,002	1,870,817	613,002	-1,257,815.00	-67.23
Total Revenue Accounts:	27,417,115	34,488,918	12,378,780	28,121,540	7,233,434	0	7,233,434	27,417,115	7,233,434	-27,255,484.00	-79.02
Total Roads Capital Fund:	27,417,115	34,488,918	12,378,780	28,121,540	7,233,434	0	7,233,434	27,417,115	7,233,434	-27,255,484.00	-79.02
Department 27 Public Works											
<i>Revenue Accounts</i>											
3080000 - Budgeted Begining Fund Balance	2,400,000	2,580,851	0	0	0	0	0	2,400,000	0	-2,580,851.00	-100.00
3438300 - Storm Drainage Fees/Charges	2,691,567	2,691,567	2,873,983	2,691,567	0	0	0	2,691,567	0	-2,691,567.00	-100.00
3611100 - Investment Interest	62,500	62,500	121,247	181,871	0	0	0	62,500	0	-62,500.00	-100.00
3611110 - LGIP Investment Interest	0	0	20,200	30,300	0	0	0	0	0	0.00	0.00
3970000 - Operating Transfers In	25,000	25,000	50,000	25,000	0	0	0	0	0	-25,000.00	-100.00
Total Revenue Accounts:	5,179,067	5,359,918	3,065,430	2,928,738	0	0	0	5,154,067	0	-5,359,918.00	-100.00
Department 30 Surface Water CIP											
<i>Revenue Accounts</i>											

Object	2006 Adopted Budget	2006 Current Budget	2006 YTD Actuals	2006 Current Year Est.	2007 Dept Request	2007 Service Package	2007 Proposed Budget	2007 Base Budget	2007 Final Budget	Change in Budget	Pct Chg
3080000 - Budgeted Begining Fund Balance	0	313,164	0	0	549,449	60,000	609,449	0	609,449	296,285.00	94.61
3379000 - Interlocal Government-Other	0	43,348	0	0	0	0	0	0	0	-43,348.00	-100.00
3438300 - Storm Drainage Fees/Charges	0	0	-1,427,972	0	2,933,808	0	2,933,808	0	2,933,808	2,933,808.00	0.00
3611100 - Investment Interest	151,786	151,786	22,148	228,356	372,500	0	372,500	151,786	372,500	220,714.00	145.41
3611110 - LGIP Investment Interest	0	0	86,718	290,453	0	0	0	0	0	0.00	0.00
3918001 - PWTf Loan(Gov)-3rd Ave Drainag	0	0	0	0	0	0	0	0	0	0.00	0.00
3918002 - PWTf Loan(Gov)-Ron Bog Drainage	0	0	0	437,750	2,033,200	0	2,033,200	0	2,033,200	2,033,200.00	0.00
3970000 - Operating Transfers In	3,159,881	3,159,881	1,554,940	0	0	0	0	3,159,881	0	-3,159,881.00	-100.00
Total Revenue Accounts:	3,311,667	3,668,179	235,834	956,559	5,888,957	60,000	5,948,957	3,311,667	5,948,957	2,280,778.00	62.17
Total SWM Enterprise Fund:	8,490,734	9,028,097	3,301,264	3,885,297	5,888,957	60,000	5,948,957	8,465,734	5,948,957	-3,079,140.00	-34.10
Department 27 Public Works											
<i>Revenue Accounts</i>											
3611100 - Investment Interest	1,250	1,250	496	648	1,250	0	1,250	1,250	1,250	0.00	0.00
3611110 - LGIP Investment Interest	0	0	8,278	12,417	0	0	0	0	0	0.00	0.00
3630000 - Insurance Premiums/Recovery	1,000	1,000	0	0	1,000	0	1,000	1,000	1,000	0.00	0.00
3651000 - Interfund Equip/Vehicle Rents	86,467	86,467	85,366	86,467	137,738	0	137,738	123,238	137,738	51,271.00	59.29
3952000 - Comp. Loss of Assets-Ins. Recr	0	0	1,250	1,250	0	0	0	0	0	0.00	0.00
Total Revenue Accounts:	88,717	88,717	95,390	100,782	139,988	0	139,988	125,488	139,988	51,271.00	57.79
Total Vehicle Operations/Maintenance:	88,717	88,717	95,390	100,782	139,988	0	139,988	125,488	139,988	51,271.00	57.79
Department 16 Finance											
<i>Revenue Accounts</i>											
3611100 - Investment Interest	15,000	15,000	27,382	30,000	30,000	0	30,000	15,000	30,000	15,000.00	100.00
3611110 - LGIP Investment Interest	0	0	10,050	16,000	16,000	0	16,000	0	16,000	16,000.00	0.00
3652000 - Interfund Equip Rent-Long Term	184,308	184,308	190,810	190,810	169,569	0	169,569	145,516	169,569	-14,739.00	-8.00
3970000 - Operating Transfers In	100,000	100,000	100,000	100,000	100,000	0	100,000	100,000	100,000	0.00	0.00
Total Revenue Accounts:	299,308	299,308	328,242	336,810	315,569	0	315,569	260,516	315,569	16,261.00	5.43
Total Equipment Replace/Deprec Fund:	299,308	299,308	328,242	336,810	315,569	0	315,569	260,516	315,569	16,261.00	5.43
Department 16 Finance											
<i>Revenue Accounts</i>											
3611100 - Investment Interest	450	450	1,097	1,300	250	0	250	450	250	-200.00	-44.44
3611110 - LGIP Investment Interest	0	0	637	1,000	250	0	250	0	250	250.00	0.00
3970000 - Operating Transfers In	10,000	10,000	10,000	30,000	10,000	0	10,000	10,000	10,000	0.00	0.00
Total Revenue Accounts:	10,450	10,450	11,734	32,300	10,500	0	10,500	10,450	10,500	50.00	0.47
Total Unemployment Fund:	10,450	10,450	11,734	32,300	10,500	0	10,500	10,450	10,500	50.00	0.47
Report Total	81,869,270	95,288,463	36,878,736	85,428,228	68,198,945	281,839	68,480,784	80,438,448	68,480,784	-26,807,679.00	0.47

Object	2006 Adopted Budget	2006 Current Budget	2006 YTD Actuals	2006 Current Year Est.	2007 Dept Request	2007 Service Package	2007 Proposed Budget	2007 Base Budget	2007 Final Budget	Change in Budget	Pct Chg
Department 10 City Council											
<i>Expense Accounts</i>											
5110000 - Salaries	60,900	60,900	48,213	60,900	60,900	0	60,900	60,900	60,900	0.00	0.00
5210000 - Benefits	0	0	0	0	0	0	0	0	0	0.00	0.00
5212000 - Social Security Replace Progm	3,776	3,776	2,600	3,776	3,776	0	3,776	3,776	3,776	0.00	0.00
5214000 - PERS	1,030	1,030	825	1,029	2,048	0	2,048	2,048	2,048	1,017.77	98.81
5215000 - Insurance Premium Allowance	48,972	48,972	39,789	48,972	52,164	0	52,164	52,164	52,164	3,192.00	6.51
5220000 - Medicare	883	883	808	883	883	0	883	883	883	0.00	0.00
5230000 - Labor & Industries	877	877	614	877	923	0	923	923	923	45.91	5.23
5310000 - Office Supplies	1,000	1,000	1,007	1,075	2,000	0	2,000	1,000	2,000	1,000.00	100.00
5410000 - Professional Services	10,000	10,000	13,210	15,000	10,000	0	10,000	10,000	10,000	0.00	0.00
5425000 - Postage	0	0	24	50	0	0	0	0	0	0.00	0.00
5430000 - Travel(Lodge,meals,miles,Food)	32,500	32,500	25,454	32,500	32,500	0	32,500	32,500	32,500	0.00	0.00
5450000 - Operating Rentals & Lease	0	0	261	261	1,500	0	1,500	1,500	1,500	1,500.00	0.00
5491000 - Dues, Subscriptions	0	0	5	0	0	0	0	0	0	0.00	0.00
5493000 - Printing & Binding	0	0	47	0	0	0	0	0	0	0.00	0.00
5494000 - Registration/Training/Admissn	7,800	7,800	7,645	7,800	7,800	0	7,800	7,800	7,800	0.00	0.00
5510000 - Intergovt Professional Service	0	0	167	0	0	0	0	0	0	0.00	0.00
Total Expense Accounts:	167,738	167,738	140,669	173,123	174,494	0	174,494	173,494	174,494	6,755.68	4.02
Department 11 City Manager											
<i>Expense Accounts</i>											
5110000 - Salaries	570,267	576,889	447,299	548,703	544,490	0	544,490	544,490	544,490	-32,398.53	-5.61
5111000 - Salaries-Extra Help	0	0	4,552	4,552	0	0	0	0	0	0.00	0.00
5112000 - Overtime	0	0	308	308	0	0	0	0	0	0.00	0.00
5115000 - Vacation Buy-Out	0	0	746	0	0	0	0	0	0	0.00	0.00
5210000 - Benefits	0	0	0	0	0	0	0	0	0	0.00	0.00
5211000 - Benefits - Extra Help	0	0	0	0	0	0	0	0	0	0.00	0.00
5212000 - Social Security Replace Progm	35,078	35,488	22,865	36,303	33,461	0	33,461	33,461	33,461	-2,026.99	-5.71
5213000 - Soc Sec Replace Pgm-Xtra Help	0	0	4,257	4,257	0	0	0	0	0	0.00	0.00
5214000 - PERS	13,273	13,470	9,898	12,262	27,054	0	27,054	27,054	27,054	13,583.91	100.84
5214001 - CM Retirement Plan	10,352	10,366	7,502	8,576	3,303	0	3,303	3,303	3,303	-7,062.83	-68.13
5215000 - Insurance Premium Allowance	64,488	64,488	46,667	61,759	67,796	0	67,796	67,796	67,796	3,308.77	5.13
5220000 - Medicare	8,204	8,299	6,009	7,955	7,825	0	7,825	7,825	7,825	-473.54	-5.70
5221000 - Medicare - Extra Help	0	0	996	996	0	0	0	0	0	0.00	0.00
5230000 - Labor & Industries	3,133	3,133	2,101	4,227	4,309	0	4,309	4,309	4,309	1,175.45	37.51
5231000 - Labor & Industries-Extra Help	0	0	28	28	0	0	0	0	0	0.00	0.00
5310000 - Office Supplies	5,000	5,000	5,421	6,000	5,000	0	5,000	5,000	5,000	0.00	0.00
5320000 - Operating Supplies	500	500	398	398	500	0	500	500	500	0.00	0.00
5330000 - Program Supplies	0	0	193	122	0	0	0	0	0	0.00	0.00
5340000 - Supplies Packaged for Resale	0	0	0	0	0	0	0	0	0	0.00	0.00

City of Shoreline - 2007 Proposed Budget

Comparative Budget Worksheet By Object

APPENDIX

Object	2006 Adopted Budget	2006 Current Budget	2006 YTD Actuals	2006 Current Year Est.	2007 Dept Request	2007 Service Package	2007 Proposed Budget	2007 Base Budget	2007 Final Budget	Change in Budget	Pct Chg
5350000 - Small Tools/Minor Equipment	3,000	3,000	393	14,900	3,000	0	3,000	3,000	3,000	0.00	0.00
5360000 - Software/Upgrades/Licenses	0	0	324	324	0	0	0	0	0	0.00	0.00
5410000 - Professional Services	73,350	73,350	23,643	41,059	51,350	0	51,350	58,350	51,350	-22,000.00	-29.99
5420000 - Telephone	5,156	5,156	4,347	6,156	5,156	0	5,156	5,156	5,156	0.00	0.00
5425000 - Postage	2,500	2,500	53	2,513	1,500	0	1,500	1,500	1,500	-1,000.00	-40.00
5430000 - Travel(Lodge,meals,miles,Food)	18,000	18,000	14,099	15,500	16,200	0	16,200	16,200	16,200	-1,800.00	-10.00
5450000 - Operating Rentals & Lease	2,700	2,700	218	0	500	0	500	500	500	-2,200.00	-81.48
5480000 - Repairs & Maintenance	1,650	1,650	0	500	1,650	0	1,650	1,650	1,650	0.00	0.00
5491000 - Dues, Subscriptions	4,900	4,900	3,137	4,700	4,430	0	4,430	4,430	4,430	-470.00	-9.59
5493000 - Printing & Binding	4,000	4,000	190	10,560	4,000	0	4,000	4,000	4,000	0.00	0.00
5494000 - Registration/Training/Admissn	14,000	14,000	5,165	6,000	14,000	0	14,000	14,000	14,000	0.00	0.00
5510000 - Intergovt Professional Service	17,469	17,469	21,295	24,275	19,828	0	19,828	17,469	19,828	2,359.00	13.50
5640000 - Machinery & Equipment	0	0	0	56,531	0	0	0	0	0	0.00	0.00
Total Expense Accounts:	857,020	864,358	632,104	879,464	815,352	0	815,352	819,993	815,352	-49,004.76	-5.66
Department 12 City Clerk											
<i>Expense Accounts</i>											
5110000 - Salaries	214,230	214,517	165,264	205,330	218,355	0	218,355	218,355	218,355	3,837.58	1.78
5111000 - Salaries-Extra Help	2,840	2,840	1,516	2,840	2,840	0	2,840	2,840	2,840	0.00	0.00
5112000 - Overtime	2,500	2,500	0	0	1,500	0	1,500	2,500	1,500	-1,000.00	-40.00
5210000 - Benefits	0	0	0	0	0	0	0	0	0	0.00	0.00
5211000 - Benefits - Extra Help	0	0	0	0	0	0	0	0	0	0.00	0.00
5212000 - Social Security Replace Progrm	13,282	13,300	10,078	12,730	13,538	0	13,538	13,538	13,538	237.93	1.78
5213000 - Soc Sec Replace Pgm-Xtra Help	177	177	94	176	177	0	177	177	177	0.00	0.00
5214000 - PERS	6,566	6,575	4,731	6,209	12,530	0	12,530	12,530	12,530	5,955.01	90.57
5215000 - Insurance Premium Allowance	42,370	42,370	35,904	47,464	48,926	0	48,926	48,926	48,926	6,556.53	15.47
5220000 - Medicare	3,106	3,111	2,394	2,978	3,166	0	3,166	3,166	3,166	55.65	1.78
5221000 - Medicare - Extra Help	41	41	22	41	41	0	41	41	41	0.00	0.00
5230000 - Labor & Industries	1,127	1,127	764	903	1,378	0	1,378	1,378	1,378	250.93	22.26
5231000 - Labor & Industries-Extra Help	51	51	26	51	51	0	51	51	51	0.00	0.00
5310000 - Office Supplies	6,500	6,500	2,900	4,700	5,500	0	5,500	6,500	5,500	-1,000.00	-15.38
5350000 - Small Tools/Minor Equipment	2,000	2,000	344	1,000	2,000	0	2,000	2,000	2,000	0.00	0.00
5410000 - Professional Services	66,895	66,895	31,888	54,000	63,395	0	63,395	66,895	63,395	-3,500.00	-5.23
5425000 - Postage	1,000	1,000	40	1,035	1,000	0	1,000	1,000	1,000	0.00	0.00
5430000 - Travel(Lodge,meals,miles,Food)	5,150	5,150	1,451	8,615	6,850	0	6,850	5,150	6,850	1,700.00	33.00
5440000 - Advertising	4,000	4,000	6,457	6,132	4,000	0	4,000	4,000	4,000	0.00	0.00
5450000 - Operating Rentals & Lease	8,000	8,000	8,896	11,000	11,000	0	11,000	8,000	11,000	3,000.00	37.50
5480000 - Repairs & Maintenance	4,000	4,000	2,089	2,089	4,000	0	4,000	4,000	4,000	0.00	0.00
5491000 - Dues, Subscriptions	905	905	756	800	680	0	680	905	680	-225.00	-24.86
5492000 - Filing,Recording,Witness Fees	0	0	170	100	0	0	0	0	0	0.00	0.00
5493000 - Printing & Binding	300	300	0	300	300	0	300	300	300	0.00	0.00

Object	2006 Adopted Budget	2006 Current Budget	2006 YTD Actuals	2006 Current Year Est.	2007 Dept Request	2007 Service Package	2007 Proposed Budget	2007 Base Budget	2007 Final Budget	Change in Budget	Pct Chg
5494000 - Registration/Training/Admissn	1,800	1,800	2,648	2,900	1,800	0	1,800	1,800	1,800	0.00	0.00
Total Expense Accounts:	386,840	387,159	278,432	371,393	403,027	0	403,027	404,052	403,027	15,868.63	4.09
Department 13	Community/Government Rel										
<i>Expense Accounts</i>											
5110000 - Salaries	232,839	236,312	191,783	236,312	253,373	0	253,373	253,373	253,373	17,061.86	7.22
5111000 - Salaries-Extra Help	0	0	0	0	0	0	0	0	0	0.00	0.00
5112000 - Overtime	0	0	122	122	0	0	0	0	0	0.00	0.00
5210000 - Benefits	0	0	0	0	0	0	0	0	0	0.00	0.00
5212000 - Social Security Replace Progrm	14,435	14,651	11,900	14,651	15,709	0	15,709	15,709	15,709	1,057.84	7.22
5213000 - Soc Sec Replace Pgm-Xtra Help	0	0	0	0	0	0	0	0	0	0.00	0.00
5214000 - PERS	7,137	7,242	5,447	7,242	14,536	0	14,536	14,536	14,536	7,293.09	100.70
5215000 - Insurance Premium Allowance	32,172	32,172	25,035	32,172	39,188	0	39,188	39,188	39,188	7,016.05	21.80
5220000 - Medicare	3,377	3,427	2,920	3,427	3,673	0	3,673	3,673	3,673	247.38	7.21
5221000 - Medicare - Extra Help	0	0	0	0	0	0	0	0	0	0.00	0.00
5230000 - Labor & Industries	1,038	1,038	714	1,038	1,340	0	1,340	1,340	1,340	302.72	29.16
5231000 - Labor & Industries-Extra Help	0	0	0	0	0	0	0	0	0	0.00	0.00
5310000 - Office Supplies	1,750	1,750	2,016	3,650	2,000	0	2,000	1,750	2,000	250.00	14.28
5320000 - Operating Supplies	900	900	248	500	300	0	300	900	300	-600.00	-66.66
5330000 - Program Supplies	0	0	1,983	5,500	7,400	0	7,400	0	7,400	7,400.00	0.00
5350000 - Small Tools/Minor Equipment	3,000	3,000	478	650	300	0	300	3,000	300	-2,700.00	-90.00
5360000 - Software/Upgrades/Licenses	1,000	1,000	0	0	0	0	0	1,000	0	-1,000.00	-100.00
5410000 - Professional Services	128,875	128,875	51,918	125,000	107,000	0	107,000	128,875	107,000	-21,875.00	-16.97
5420000 - Telephone	0	0	262	562	0	0	0	0	0	0.00	0.00
5425000 - Postage	38,100	38,100	29,609	37,100	38,000	0	38,000	38,100	38,000	-100.00	-0.26
5430000 - Travel(Lodge,meals,miles,Food)	10,200	10,200	7,018	9,544	9,500	0	9,500	10,200	9,500	-700.00	-6.86
5440000 - Advertising	10,500	10,500	8,050	10,500	10,500	0	10,500	10,500	10,500	0.00	0.00
5450000 - Operating Rentals & Lease	800	800	618	800	2,000	0	2,000	800	2,000	1,200.00	150.00
5460000 - Insurance	2,600	2,600	1,945	2,200	2,200	0	2,200	2,600	2,200	-400.00	-15.38
5476000 - Utilities-Cable TV	756	756	567	756	756	0	756	756	756	0.00	0.00
5480000 - Repairs & Maintenance	2,500	2,500	2,928	3,000	3,100	0	3,100	2,500	3,100	600.00	24.00
5491000 - Dues, Subscriptions	500	500	1,468	2,056	700	0	700	500	700	200.00	40.00
5493000 - Printing & Binding	35,000	35,000	17,030	35,000	35,000	0	35,000	35,000	35,000	0.00	0.00
5494000 - Registration/Training/Admissn	2,500	2,500	1,576	2,300	2,125	0	2,125	2,500	2,125	-375.00	-15.00
5495000 - City Grants to Other Agencies	30,000	46,335	7,651	26,000	30,000	0	30,000	30,000	30,000	-16,335.00	-35.25
5640000 - Machinery & Equipment	0	0	0	0	0	0	0	0	0	0.00	0.00
Total Expense Accounts:	559,979	580,158	373,286	560,082	578,700	0	578,700	596,800	578,700	-1,456.06	-0.25
Department 14	Human Services										
<i>Expense Accounts</i>											
5110000 - Salaries	125,765	125,931	103,504	125,931	131,214	0	131,214	131,214	131,214	5,283.40	4.19
5111000 - Salaries-Extra Help	0	0	185	143	0	0	0	0	0	0.00	0.00

Comparative Budget Worksheet By Object

Object	2006 Adopted Budget	2006 Current Budget	2006 YTD Actuals	2006 Current Year Est.	2007 Dept Request	2007 Service Package	2007 Proposed Budget	2007 Base Budget	2007 Final Budget	Change in Budget	Pct Chg
5210000 - Benefits	0	0	0	0	0	0	0	0	0	0.00	0.00
5212000 - Social Security Replace Progm	7,797	7,808	6,140	7,808	8,135	0	8,135	8,135	8,135	327.56	4.19
5213000 - Soc Sec Replace Pgm-Xtra Help	0	0	11	9	0	0	0	0	0	0.00	0.00
5214000 - PERS	3,855	3,860	2,962	3,860	7,526	0	7,526	7,526	7,526	3,666.17	94.97
5214002 - PERS - Extra Help	0	0	5	3	0	0	0	0	0	0.00	0.00
5215000 - Insurance Premium Allowance	20,266	20,266	16,227	20,266	21,371	0	21,371	21,371	21,371	1,105.70	5.45
5220000 - Medicare	1,824	1,826	1,517	1,826	1,903	0	1,903	1,903	1,903	76.61	4.19
5221000 - Medicare - Extra Help	0	0	3	2	0	0	0	0	0	0.00	0.00
5230000 - Labor & Industries	534	534	374	534	691	0	691	691	691	156.93	29.38
5231000 - Labor & Industries-Extra Help	0	0	2	2	0	0	0	0	0	0.00	0.00
5310000 - Office Supplies	1,200	1,200	363	600	1,200	0	1,200	1,200	1,200	0.00	0.00
5320000 - Operating Supplies	0	0	0	150	0	0	0	0	0	0.00	0.00
5330000 - Program Supplies	0	0	108	200	400	0	400	0	400	400.00	0.00
5350000 - Small Tools/Minor Equipment	0	0	322	322	0	0	0	0	0	0.00	0.00
5410000 - Professional Services	25,000	25,000	0	15,000	5,000	0	5,000	5,000	5,000	-20,000.00	-80.00
5420000 - Telephone	0	0	44	307	0	0	0	0	0	0.00	0.00
5425000 - Postage	0	0	24	50	0	0	0	0	0	0.00	0.00
5430000 - Travel(Lodge,meals,miles,Food)	2,100	2,100	381	2,100	2,500	0	2,500	2,100	2,500	400.00	19.04
5440000 - Advertising	900	900	262	900	600	0	600	900	600	-300.00	-33.33
5491000 - Dues, Subscriptions	1,000	1,000	228	400	1,000	0	1,000	1,000	1,000	0.00	0.00
5493000 - Printing & Binding	300	300	0	100	300	0	300	300	300	0.00	0.00
5494000 - Registration/Training/Admissn	4,100	4,100	1,213	3,500	3,500	0	3,500	4,100	3,500	-600.00	-14.63
5495000 - City Grants to Other Agencies	392,384	392,384	222,659	392,384	406,670	0	406,670	392,384	406,670	14,286.00	3.64
Total Expense Accounts:	587,025	587,209	356,534	576,397	592,010	0	592,010	577,824	592,010	4,802.37	0.81
Department 15 City Attorney											
<i>Expense Accounts</i>											
5110000 - Salaries	222,524	229,289	185,937	229,289	247,292	0	247,292	247,292	247,292	18,003.96	7.85
5111000 - Salaries-Extra Help	0	0	0	0	0	0	0	0	0	0.00	0.00
5112000 - Overtime	100	100	28	100	100	0	100	100	100	0.00	0.00
5210000 - Benefits	0	0	0	0	0	0	0	0	0	0.00	0.00
5212000 - Social Security Replace Progm	13,796	14,216	11,226	14,216	15,332	0	15,332	15,332	15,332	1,116.25	7.85
5213000 - Soc Sec Replace Pgm-Xtra Help	0	0	0	0	0	0	0	0	0	0.00	0.00
5214000 - PERS	6,820	7,028	5,253	7,028	14,188	0	14,188	14,188	14,188	7,160.43	101.88
5215000 - Insurance Premium Allowance	27,576	27,576	21,182	27,576	28,477	0	28,477	28,477	28,477	901.09	3.26
5220000 - Medicare	3,227	3,325	2,793	3,325	3,586	0	3,586	3,586	3,586	261.06	7.85
5221000 - Medicare - Extra Help	0	0	0	0	0	0	0	0	0	0.00	0.00
5230000 - Labor & Industries	890	890	593	890	1,191	0	1,191	1,191	1,191	300.73	33.78
5231000 - Labor & Industries-Extra Help	0	0	0	0	0	0	0	0	0	0.00	0.00
5310000 - Office Supplies	2,000	2,000	254	2,000	2,000	0	2,000	2,000	2,000	0.00	0.00
5320000 - Operating Supplies	0	0	3	0	0	0	0	0	0	0.00	0.00

Object	2006 Adopted Budget	2006 Current Budget	2006 YTD Actuals	2006 Current Year Est.	2007 Dept Request	2007 Service Package	2007 Proposed Budget	2007 Base Budget	2007 Final Budget	Change in Budget	Pct Chg
5350000 - Small Tools/Minor Equipment	0	0	1,025	0	0	0	0	0	0	0.00	0.00
5410000 - Professional Services	228,000	228,000	188,748	257,750	213,000	0	213,000	228,000	213,000	-15,000.00	-6.57
5425000 - Postage	300	300	305	300	300	0	300	300	300	0.00	0.00
5430000 - Travel(Lodge,meals,miles,Food)	2,100	2,100	1,195	2,100	2,100	0	2,100	2,100	2,100	0.00	0.00
5450000 - Operating Rentals & Lease	0	0	0	0	15,000	0	15,000	15,000	15,000	15,000.00	0.00
5491000 - Dues, Subscriptions	5,866	5,866	4,025	5,866	5,866	0	5,866	5,866	5,866	0.00	0.00
5492000 - Filing,Recording,Witness Fees	250	250	278	250	250	0	250	250	250	0.00	0.00
5493000 - Printing & Binding	0	0	34	0	0	0	0	0	0	0.00	0.00
5494000 - Registration/Training/Admissn	2,100	2,100	1,434	2,100	2,100	0	2,100	2,100	2,100	0.00	0.00
5496000 - Judgements/Settlements	0	0	939	250	0	0	0	0	0	0.00	0.00
5499000 - Miscellaneous Expenses	0	0	119	0	0	0	0	0	0	0.00	0.00
5510000 - Intergovt Professional Service	0	0	0	0	0	0	0	0	0	0.00	0.00
5640000 - Machinery & Equipment	0	0	0	0	0	0	0	0	0	0.00	0.00
Total Expense Accounts:	515,549	523,040	425,371	553,040	550,782	0	550,782	565,782	550,782	27,743.52	5.30
Department 16 Finance											
<i>Expense Accounts</i>											
5110000 - Salaries	1,142,723	1,148,080	892,525	1,124,303	1,200,206	11,179	1,211,385	1,200,206	1,211,385	63,306.12	5.51
5111000 - Salaries-Extra Help	23,379	23,379	14,230	26,005	23,379	0	23,379	23,379	23,379	0.00	0.00
5112000 - Overtime	3,485	3,485	2,428	4,973	4,580	0	4,580	3,485	4,580	1,095.00	31.42
5112100 - Overtime-Extra Help	0	0	0	0	0	0	0	0	0	0.00	0.00
5114000 - Callback Pay	0	0	340	338	0	0	0	0	0	0.00	0.00
5115000 - Vacation Buy-Out	50,000	50,000	3,137	0	30,000	0	30,000	50,000	30,000	-20,000.00	-40.00
5210000 - Penefits	0	0	0	0	0	0	0	0	0	0.00	0.00
5211000 - Benefits - Extra Help	0	0	0	0	0	0	0	0	0	0.00	0.00
5212000 - Social Security Replace Progrm	70,850	71,177	54,916	70,138	74,413	693	75,106	74,413	75,106	3,929.30	5.52
5213000 - Soc Sec Replace Pgm-Xtra Help	1,453	1,453	882	1,611	1,453	0	1,453	1,453	1,453	0.00	0.00
5214000 - PERS	35,026	35,187	25,694	34,419	68,848	641	69,490	68,848	69,490	34,304.54	97.49
5214002 - PERS - Extra Help	232	232	345	452	232	0	232	232	232	0.00	0.00
5214004 - PERS-Back Contrib. Employee	0	0	-2,239	0	0	0	0	0	0	0.00	0.00
5215000 - Insurance Premium Allowance	168,539	168,539	135,291	167,051	182,900	1,187	184,087	182,900	184,087	15,546.90	9.22
5220000 - Medicare	16,568	16,642	13,456	16,569	17,403	162	17,566	17,403	17,566	921.31	5.53
5221000 - Medicare - Extra Help	340	340	205	377	340	0	340	340	340	0.00	0.00
5230000 - Labor & Industries	5,137	5,137	3,302	4,793	6,563	86	6,650	6,563	6,650	1,510.74	29.40
5231000 - Labor & Industries-Extra Help	308	308	180	308	308	0	308	308	308	0.00	0.00
5310000 - Office Supplies	12,675	12,675	4,399	11,090	12,775	0	12,775	12,675	12,775	100.00	0.78
5320000 - Operating Supplies	49,113	49,113	33,184	58,654	59,088	0	59,088	49,113	59,088	9,975.00	20.31
5330000 - Program Supplies	0	0	0	0	0	0	0	0	0	0.00	0.00
5350000 - Small Tools/Minor Equipment	4,200	4,200	16,512	19,501	4,200	0	4,200	4,200	4,200	0.00	0.00
5360000 - Software/Upgrades/Licenses	40,500	60,450	44,361	59,700	40,000	0	40,000	40,500	40,000	-20,450.00	-33.82
5410000 - Professional Services	179,860	188,160	74,673	149,129	167,320	-12,000	155,320	179,860	155,320	-32,840.08	-17.45

Object	2006 Adopted Budget	2006 Current Budget	2006 YTD Actuals	2006 Current Year Est.	2007 Dept Request	2007 Service Package	2007 Proposed Budget	2007 Base Budget	2007 Final Budget	Change in Budget	Pct Chg
5420000 - Telephone	238,400	238,400	179,883	265,231	277,954	0	277,954	287,400	277,954	39,554.00	16.59
5425000 - Postage	9,062	9,062	28,860	12,662	14,667	0	14,667	9,062	14,667	5,605.00	61.85
5430000 - Travel(Lodge,meals,miles,Food)	20,375	20,375	3,430	15,512	22,975	0	22,975	20,375	22,975	2,600.00	12.76
5440000 - Advertising	9,020	9,020	4,556	7,000	9,020	-1,949	7,071	9,020	7,071	-1,948.66	-21.60
5450000 - Operating Rentals & Lease	19,944	19,944	10,554	22,190	22,500	0	22,500	19,944	22,500	2,556.00	12.81
5460000 - Insurance	386,200	386,200	388,542	388,542	437,042	0	437,042	436,962	437,042	50,842.00	13.16
5480000 - Repairs & Maintenance	189,545	189,545	86,492	178,410	195,252	0	195,252	204,545	195,252	5,707.00	3.01
5491000 - Dues, Subscriptions	120,182	120,182	93,392	113,801	116,974	0	116,974	120,367	116,974	-3,208.00	-2.66
5493000 - Printing & Binding	12,825	12,825	4,945	9,382	8,325	0	8,325	12,825	8,325	-4,500.00	-35.08
5494000 - Registration/Training/Admissn	31,835	31,835	10,929	33,775	29,385	0	29,385	31,835	29,385	-2,450.00	-7.69
5495000 - City Grants to Other Agencies	0	0	0	0	0	0	0	0	0	0.00	0.00
5496000 - Judgements/Settlements	0	0	253,669	253,669	0	0	0	0	0	0.00	0.00
5499000 - Miscellaneous Expenses	0	0	-122	-122	0	0	0	0	0	0.00	0.00
5510000 - Intergovt Professional Service	229,925	229,925	190,989	255,650	151,779	0	151,779	137,679	151,779	-78,146.00	-33.98
5630000 - Other Improvements	0	0	0	0	0	0	0	0	0	0.00	0.00
5640000 - Machinery & Equipment	0	0	0	0	0	0	0	0	0	0.00	0.00
5910000 - Interfund Chg-Equip Replacemnt	74,574	74,574	74,574	74,574	29,610	0	29,610	29,610	29,610	-44,964.00	-60.29
5950000 - Interfund Vehicle Operat/Maint	5,541	5,541	5,541	5,541	2,568	0	2,568	2,568	2,568	-2,973.00	-53.65
5992000 - Contingency	0	0	0	0	2,304	61,161	63,465	0	63,465	63,465.00	0.00
5994000 - Operational Contingency	250,000	250,000	0	0	250,000	0	250,000	250,000	250,000	0.00	0.00
5995000 - Other Reserves	567,869	501,663	0	0	285,000	0	285,000	255,000	285,000	-216,663.14	-43.18
Total Expense Accounts:	3,969,685	3,937,648	2,654,055	3,385,228	3,749,363	61,160	3,810,526	3,743,070	3,810,526	-127,124.97	-3.22
Department 17 City Wide											
<i>TRANSFER OUT ACCOUNTS</i>											
5970000 - Operating Transfers Out	4,244,036	4,244,036	2,226,413	4,617,018	2,598,784	-44,661	2,554,123	3,074,298	2,554,123	-1,689,913.00	-39.81
Total TRANSFER OUT ACCOUNTS:	4,244,036	4,244,036	2,226,413	4,617,018	2,598,784	-44,661	2,554,123	3,074,298	2,554,123	-1,689,913.00	-39.81
<i>Expense Accounts</i>											
5992000 - Contingency	0	0	0	0	0	0	0	0	0	0.00	0.00
Total Expense Accounts:	0	0	0	0	0	0	0	0	0	0.00	0.00
Department 18 Human Resources											
<i>Expense Accounts</i>											
5110000 - Salaries	200,812	204,589	163,743	204,589	216,012	0	216,012	216,012	216,012	11,422.99	5.58
5111000 - Salaries-Extra Help	0	0	475	155	0	0	0	0	0	0.00	0.00
5112000 - Overtime	0	0	97	97	0	0	0	0	0	0.00	0.00
5210000 - Benefits	0	0	0	0	0	0	0	0	0	0.00	0.00
5212000 - Social Security Replace Progm	12,450	12,684	10,084	12,684	13,393	0	13,393	13,393	13,393	708.40	5.58
5213000 - Soc Sec Replace Pgm-Xtra Help	0	0	29	10	0	0	0	0	0	0.00	0.00
5214000 - PERS	6,155	6,271	4,687	6,271	12,395	0	12,395	12,395	12,395	6,124.25	97.65
5214002 - PERS - Extra Help	0	0	10	0	0	0	0	0	0	0.00	0.00
5215000 - Insurance Premium Allowance	27,576	27,576	21,799	27,576	28,477	0	28,477	28,477	28,477	901.09	3.26

Object	2006 Adopted Budget	2006 Current Budget	2006 YTD Actuals	2006 Current Year Est.	2007 Dept Request	2007 Service Package	2007 Proposed Budget	2007 Base Budget	2007 Final Budget	Change in Budget	Pct Chg
5220000 - Medicare	2,912	2,966	2,489	2,966	3,132	0	3,132	3,132	3,132	166.42	5.61
5221000 - Medicare - Extra Help	0	0	7	2	0	0	0	0	0	0.00	0.00
5230000 - Labor & Industries	890	890	600	890	1,148	0	1,148	1,148	1,148	257.87	28.97
5231000 - Labor & Industries-Extra Help	0	0	9	5	0	0	0	0	0	0.00	0.00
5310000 - Office Supplies	2,150	2,150	2,374	2,150	2,150	0	2,150	2,150	2,150	0.00	0.00
5320000 - Operating Supplies	0	0	0	0	0	0	0	0	0	0.00	0.00
5330000 - Program Supplies	6,500	6,500	4,616	6,500	9,250	0	9,250	6,500	9,250	2,750.00	42.30
5360000 - Software/Upgrades/Licenses	500	500	0	231	500	0	500	500	500	0.00	0.00
5410000 - Professional Services	28,375	28,375	11,519	28,375	28,375	0	28,375	28,375	28,375	0.00	0.00
5425000 - Postage	1,000	1,000	0	1,000	1,000	0	1,000	1,000	1,000	0.00	0.00
5430000 - Travel(Lodge,meals,miles,Food)	4,950	4,950	3,052	4,950	4,950	0	4,950	4,950	4,950	0.00	0.00
5440000 - Advertising	66,731	66,731	42,060	66,731	66,731	0	66,731	66,731	66,731	0.00	0.00
5491000 - Dues, Subscriptions	1,840	1,840	1,065	1,840	1,840	0	1,840	1,840	1,840	0.00	0.00
5493000 - Printing & Binding	200	200	0	200	200	0	200	200	200	0.00	0.00
5494000 - Registration/Training/Admissn	2,000	2,000	1,798	2,000	2,000	0	2,000	2,000	2,000	0.00	0.00
Total Expense Accounts:	365,041	369,222	270,513	369,222	391,553	0	391,553	388,803	391,553	22,331.02	6.04
Department 19 Customer Services											
<i>Expense Accounts</i>											
5110000 - Salaries	267,276	267,615	205,065	267,615	280,657	0	280,657	280,657	280,657	13,042.49	4.87
5111000 - Salaries-Extra Help	4,580	4,580	0	4,580	4,580	0	4,580	4,580	4,580	0.00	0.00
5112000 - Overtime	5,000	5,000	2,188	5,000	5,000	0	5,000	5,000	5,000	0.00	0.00
5113000 - Standby Pay	15,200	21,200	15,909	21,200	21,573	0	21,573	21,573	21,573	373.00	1.75
5114000 - Callback Pay	7,000	7,000	6,785	7,000	7,000	0	7,000	7,000	7,000	0.00	0.00
5115000 - Vacation Buy-Out	0	0	2,439	1,385	0	0	0	0	0	0.00	0.00
5210000 - Benefits	0	0	0	0	0	0	0	0	0	0.00	0.00
5211000 - Benefits - Extra Help	0	0	0	0	0	0	0	0	0	0.00	0.00
5212000 - Social Security Replace Progrm	16,571	16,592	14,280	16,592	17,401	0	17,401	17,401	17,401	808.66	4.87
5213000 - Soc Sec Replace Pgm-Xtra Help	322	322	0	322	284	0	284	322	284	-38.00	-11.80
5214000 - PERS	8,192	8,202	6,656	8,202	22,422	0	22,422	16,100	22,422	14,219.99	173.37
5215000 - Insurance Premium Allowance	49,752	49,752	40,419	49,752	57,056	0	57,056	57,056	57,056	7,304.00	14.68
5220000 - Medicare	3,876	3,880	3,424	3,880	4,069	0	4,069	4,070	4,069	189.50	4.88
5221000 - Medicare - Extra Help	77	77	0	77	84	0	84	77	84	7.00	9.09
5230000 - Labor & Industries	8,997	8,997	7,312	8,997	4,738	0	4,738	11,060	4,738	-4,259.33	-47.34
5231000 - Labor & Industries-Extra Help	108	108	0	108	63	0	63	108	63	-45.00	-41.66
5310000 - Office Supplies	1,108	1,108	906	1,108	1,108	0	1,108	1,108	1,108	0.00	0.00
5320000 - Operating Supplies	3,450	3,450	1,486	2,500	3,450	0	3,450	3,450	3,450	0.00	0.00
5350000 - Small Tools/Minor Equipment	1,000	1,000	0	250	1,000	0	1,000	1,000	1,000	0.00	0.00
5360000 - Software/Upgrades/Licenses	0	0	754	800	0	0	0	0	0	0.00	0.00
5410000 - Professional Services	3,300	3,300	0	2,000	2,000	0	2,000	3,300	2,000	-1,300.00	-39.39
5420000 - Telephone	0	0	263	500	0	0	0	0	0	0.00	0.00

Object	2006 Adopted Budget	2006 Current Budget	2006 YTD Actuals	2006 Current Year Est.	2007 Dept Request	2007 Service Package	2007 Proposed Budget	2007 Base Budget	2007 Final Budget	Change in Budget	Pct Chg
5425000 - Postage	0	0	0	0	0	0	0	0	0	0.00	0.00
5430000 - Travel(Lodge,meals,miles,Food)	2,000	2,000	2,750	2,000	2,000	0	2,000	2,000	2,000	0.00	0.00
5450000 - Operating Rentals & Lease	500	500	59	0	500	0	500	500	500	0.00	0.00
5480000 - Repairs & Maintenance	300	300	0	0	300	0	300	300	300	0.00	0.00
5491000 - Dues, Subscriptions	500	500	264	500	500	0	500	500	500	0.00	0.00
5493000 - Printing & Binding	300	300	0	150	300	0	300	300	300	0.00	0.00
5494000 - Registration/Training/Admissn	4,500	4,500	3,637	3,250	4,500	0	4,500	4,500	4,500	0.00	0.00
5510000 - Intergovt Professional Service	0	0	10	15	0	0	0	0	0	0.00	0.00
5640000 - Machinery & Equipment	0	0	0	0	0	0	0	0	0	0.00	0.00
5910000 - Interfund Chg-Equip Replacemnt	5,986	5,986	5,986	5,986	4,412	0	4,412	4,412	4,412	-1,574.00	-26.29
5950000 - Interfund Vehicle Operat/Maint	6,500	6,500	6,500	6,500	9,262	0	9,262	9,262	9,262	2,762.00	42.49
Total Expense Accounts:	416,395	422,769	327,092	420,269	454,259	0	454,259	455,636	454,259	31,490.31	7.44
Department 20 Police											
<i>Expense Accounts</i>											
5110000 - Salaries	44,949	45,011	35,736	45,011	46,738	0	46,738	46,738	46,738	1,726.80	3.83
5111000 - Salaries-Extra Help	0	0	0	0	0	0	0	0	0	0.00	0.00
5112000 - Overtime	1,000	1,000	260	1,000	1,000	0	1,000	1,000	1,000	0.00	0.00
5112100 - Overtime-Extra Help	0	0	0	0	0	0	0	0	0	0.00	0.00
5210000 - Benefits	0	0	0	0	0	0	0	0	0	0.00	0.00
5212000 - Social Security Replace Progrm	2,787	2,790	2,232	2,790	2,898	0	2,898	2,898	2,898	107.90	3.86
5213000 - Soc Sec Replace Pgm-Xtra Help	0	0	0	0	0	0	0	0	0	0.00	0.00
5214000 - PERS	1,378	1,379	982	1,379	2,681	0	2,681	2,681	2,681	1,302.01	94.41
5215000 - Insurance Premium Allowance	9,264	9,264	7,953	9,264	10,711	0	10,711	10,711	10,711	1,446.96	15.61
5220000 - Medicare	652	653	522	653	678	0	678	678	678	24.94	3.81
5221000 - Medicare - Extra Help	0	0	0	0	0	0	0	0	0	0.00	0.00
5230000 - Labor & Industries	297	297	298	297	348	0	348	348	348	51.35	17.28
5231000 - Labor & Industries-Extra Help	0	0	0	0	0	0	0	0	0	0.00	0.00
5310000 - Office Supplies	3,000	3,000	2,130	1,166	3,000	0	3,000	3,000	3,000	0.00	0.00
5320000 - Operating Supplies	11,300	11,300	8,998	6,694	11,300	0	11,300	11,300	11,300	0.00	0.00
5330000 - Program Supplies	3,000	3,000	999	1,527	3,000	0	3,000	3,000	3,000	0.00	0.00
5350000 - Small Tools/Minor Equipment	20,000	20,000	17,000	28,597	21,290	0	21,290	20,000	21,290	1,290.00	6.45
5360000 - Software/Upgrades/Licenses	0	0	0	0	0	0	0	0	0	0.00	0.00
5410000 - Professional Services	20,276	12,471	9,353	10,838	13,841	0	13,841	12,471	13,841	1,370.13	10.98
5420000 - Telephone	0	0	49	50	0	0	0	0	0	0.00	0.00
5425000 - Postage	2,564	2,564	36	53	2,564	0	2,564	2,564	2,564	0.00	0.00
5430000 - Travel(Lodge,meals,miles,Food)	8,950	8,950	4,118	2,832	8,950	0	8,950	8,950	8,950	0.00	0.00
5440000 - Advertising	0	0	471	0	0	0	0	0	0	0.00	0.00
5450000 - Operating Rentals & Lease	0	0	3,600	0	0	0	0	0	0	0.00	0.00
5471000 - Utility-Electricity	11,103	11,103	6,675	11,103	11,103	0	11,103	11,103	11,103	0.00	0.00
5472000 - Utility-Water	1,592	1,592	1,133	1,594	1,804	0	1,804	1,592	1,804	212.00	13.31

Object	2006 Adopted Budget	2006 Current Budget	2006 YTD Actuals	2006 Current Year Est.	2007 Dept Request	2007 Service Package	2007 Proposed Budget	2007 Base Budget	2007 Final Budget	Change in Budget	Pct Chg
5473000 - Utility-Gas	2,125	2,125	3,960	4,920	7,050	0	7,050	2,125	7,050	4,925.00	231.76
5474000 - UTILITY-SEWER	1,869	1,869	3,335	3,191	6,600	0	6,600	1,869	6,600	4,731.00	253.13
5480000 - Repairs & Maintenance	5,700	5,700	2,551	3,646	5,700	0	5,700	5,700	5,700	0.00	0.00
5491000 - Dues, Subscriptions	1,915	1,915	550	874	1,465	0	1,465	1,915	1,465	-450.00	-23.49
5492000 - Filing,Recording,Witness Fees	0	0	240	240	0	0	0	0	0	0.00	0.00
5493000 - Printing & Binding	1,000	1,000	382	582	1,000	0	1,000	1,000	1,000	0.00	0.00
5494000 - Registration/Training/Admissn	6,270	6,270	3,576	5,887	6,270	0	6,270	6,270	6,270	0.00	0.00
5510000 - Intergovt Professional Service	7,933,620	7,933,620	5,113,350	7,840,426	8,361,554	0	8,361,554	7,933,620	8,361,554	427,934.00	5.39
5640000 - Machinery & Equipment	0	0	0	0	0	0	0	0	0	0.00	0.00
5910000 - Interfund Chg-Equip Replacemnt	5,054	5,054	5,054	5,054	5,053	0	5,053	5,053	5,053	-1.00	-0.01
5950000 - Interfund Vehicle Operat/Maint	4,500	4,500	4,500	4,500	5,339	0	5,339	8,688	5,339	839.00	18.64
Total Expense Accounts:	8,104,165	8,096,427	5,240,043	7,994,168	8,541,937	0	8,541,937	8,105,274	8,541,937	445,510.09	5.50
Department 21 Criminal Justice											
<i>Expense Accounts</i>											
5410000 - Professional Services	134,104	134,104	94,036	145,300	150,709	0	150,709	150,709	150,709	16,605.00	12.38
5510000 - Intergovt Professional Service	839,000	839,000	767,480	1,203,100	1,228,717	0	1,228,717	842,500	1,228,717	389,717.00	46.45
Total Expense Accounts:	973,104	973,104	861,516	1,348,400	1,379,426	0	1,379,426	993,209	1,379,426	406,322.00	41.75
Department 24 Parks, Recreation, Cultural S											
<i>Expense Accounts</i>											
5110000 - Salaries	1,214,794	1,226,187	924,534	1,212,924	1,274,921	40,331	1,315,252	1,274,921	1,315,252	89,064.64	7.26
5111000 - Salaries-Extra Help	554,572	554,572	450,131	512,616	565,116	30,000	595,116	554,572	595,116	40,544.00	7.31
5112000 - Overtime	13,952	13,952	6,379	15,592	13,952	0	13,952	13,952	13,952	0.00	0.00
5112100 - Overtime-Extra Help	522	522	491	1,388	1,522	0	1,522	522	1,522	1,000.00	191.57
5113000 - Standby Pay	0	0	0	0	0	0	0	0	0	0.00	0.00
5114000 - Callback Pay	0	0	0	0	0	0	0	0	0	0.00	0.00
5115000 - Vacation Buy-Out	0	0	2,721	2,722	0	0	0	0	0	0.00	0.00
5210000 - Benefits	0	0	0	0	0	0	0	0	0	0.00	0.00
5211000 - Benefits - Extra Help	0	0	0	0	0	0	0	0	0	0.00	0.00
5212000 - Social Security Replace Progm	75,317	76,019	56,226	76,015	79,045	2,501	81,545	79,045	81,545	5,526.39	7.26
5213000 - Soc Sec Replace Pgm-Xtra Help	32,575	32,575	27,927	30,479	36,369	0	36,369	32,575	36,369	3,794.00	11.64
5214000 - PERS	37,022	37,368	26,058	37,366	73,150	2,313	75,463	73,150	75,463	38,095.35	101.94
5214002 - PERS - Extra Help	0	0	2,779	2,720	2,000	0	2,000	0	2,000	2,000.00	0.00
5215000 - Insurance Premium Allowance	257,719	257,719	199,782	257,718	275,946	9,624	285,570	275,946	285,570	27,851.03	10.80
5220000 - Medicare	17,614	17,779	13,775	17,690	18,486	585	19,071	18,486	19,071	1,292.32	7.26
5221000 - Medicare - Extra Help	7,814	7,814	6,531	7,391	8,941	0	8,941	7,814	8,941	1,127.00	14.42
5230000 - Labor & Industries	23,138	23,138	16,844	23,137	29,248	1,761	31,009	29,248	31,009	7,870.72	34.01
5231000 - Labor & Industries-Extra Help	30,560	30,560	28,712	28,969	34,363	0	34,363	30,560	34,363	3,803.00	12.44
5310000 - Office Supplies	7,100	7,100	3,536	7,600	8,050	0	8,050	7,100	8,050	950.00	13.38
5320000 - Operating Supplies	63,398	63,398	22,489	59,500	68,598	32,200	100,798	63,398	100,798	37,400.00	58.99
5330000 - Program Supplies	71,736	71,736	51,805	71,736	72,816	0	72,816	71,736	72,816	1,080.00	1.50

Object	2006 Adopted Budget	2006 Current Budget	2006 YTD Actuals	2006 Current Year Est.	2007 Dept Request	2007 Service Package	2007 Proposed Budget	2007 Base Budget	2007 Final Budget	Change in Budget	Pct Chg
5340000 - Supplies Packaged for Resale	3,800	3,800	2,044	3,800	3,800	0	3,800	3,800	3,800	0.00	0.00
5350000 - Small Tools/Minor Equipment	17,260	17,260	11,043	17,958	15,760	0	15,760	14,260	15,760	-1,500.00	-8.69
5360000 - Software/Upgrades/Licenses	0	0	5,179	5,179	0	0	0	0	0	0.00	0.00
5410000 - Professional Services	633,520	676,325	461,447	647,530	627,855	-146,078	481,777	715,779	481,777	-194,548.92	-28.76
5420000 - Telephone	0	0	526	563	0	0	0	0	0	0.00	0.00
5425000 - Postage	21,150	21,150	8,398	21,150	21,050	0	21,050	21,150	21,050	-100.00	-0.47
5430000 - Travel(Lodge,meals,miles,Food)	11,652	11,652	6,263	11,652	13,352	0	13,352	11,652	13,352	1,700.00	14.58
5440000 - Advertising	6,865	6,865	3,490	6,865	7,365	0	7,365	6,865	7,365	500.00	7.28
5450000 - Operating Rentals & Lease	22,655	22,655	13,774	22,655	26,705	0	26,705	22,655	26,705	4,050.00	17.87
5460000 - Insurance	0	0	0	0	0	0	0	0	0	0.00	0.00
5471000 - Utility-Electricity	89,298	89,298	66,411	90,114	89,298	0	89,298	89,298	89,298	0.00	0.00
5472000 - Utility-Water	154,063	154,063	91,742	109,450	104,063	0	104,063	154,063	104,063	-50,000.00	-32.45
5473000 - Utility-Gas	123,616	123,616	87,400	136,666	137,166	0	137,166	123,616	137,166	13,550.00	10.96
5474000 - UTILITY-SEWER	59,486	59,486	36,070	55,378	59,486	0	59,486	59,486	59,486	0.00	0.00
5475000 - UTILITY-GARBAGE/SOLID WAS	1,858	1,858	0	1,200	1,858	0	1,858	1,858	1,858	0.00	0.00
5480000 - Repairs & Maintenance	8,500	8,500	3,907	7,000	8,500	0	8,500	8,500	8,500	0.00	0.00
5491000 - Dues, Subscriptions	3,675	3,675	3,779	3,945	4,700	0	4,700	3,675	4,700	1,025.00	27.89
5492000 - Filing,Recording,Witness Fees	0	0	0	0	0	0	0	0	0	0.00	0.00
5493000 - Printing & Binding	37,340	37,340	23,426	37,340	41,140	0	41,140	37,340	41,140	3,800.00	10.17
5494000 - Registration/Training/Admissn	16,864	16,864	7,764	16,864	17,364	0	17,364	16,864	17,364	500.00	2.96
5495000 - City Grants to Other Agencies	136,872	136,872	86,871	136,872	139,966	0	139,966	136,872	139,966	3,094.00	2.26
5496000 - Judgements/Settlements	0	0	0	0	0	0	0	0	0	0.00	0.00
5499000 - Miscellaneous Expenses	0	0	462	464	0	0	0	0	0	0.00	0.00
5510000 - Intergovt Professional Service	8,000	8,000	5,340	7,510	8,000	0	8,000	8,000	8,000	0.00	0.00
5620000 - Buildings & Structures	0	0	0	0	0	0	0	0	0	0.00	0.00
5640000 - Machinery & Equipment	78,500	112,651	103,882	114,000	0	16,500	16,500	0	16,500	-96,151.00	-85.35
5910000 - Interfund Chg-Equip Replacemnt	31,009	31,009	31,009	31,009	41,643	0	41,643	41,642	41,643	10,634.00	34.29
5950000 - Interfund Vehicle Operat/Maint	21,747	21,747	21,747	21,747	29,960	2,500	32,460	29,959	32,460	10,713.00	49.26
Total Expense Accounts:	3,895,563	3,985,125	2,922,694	3,872,474	3,961,554	-7,763	3,953,790	4,040,359	3,953,790	-31,335.47	-0.78
Department 25 Planning & Development Sv											
<i>Expense Accounts</i>											
5110000 - Salaries	1,580,168	1,610,434	1,202,108	1,522,584	1,737,283	0	1,737,283	1,737,283	1,737,283	126,849.39	7.87
5111000 - Salaries-Extra Help	42,429	42,429	5,040	21,080	33,625	0	33,625	42,429	33,625	-8,804.00	-20.74
5112000 - Overtime	3,020	3,020	665	1,750	3,020	0	3,020	3,020	3,020	0.00	0.00
5113000 - Standby Pay	0	0	2	0	0	0	0	0	0	0.00	0.00
5210000 - Benefits	0	0	0	0	0	0	0	0	0	0.00	0.00
5212000 - Social Security Replace Progrm	97,970	99,868	73,580	97,499	107,711	0	107,711	107,712	107,711	7,842.43	7.85
5213000 - Soc Sec Replace Pgm-Xtra Help	2,630	2,630	312	1,394	2,085	0	2,085	2,630	2,085	-545.00	-20.72
5214000 - PERS	48,204	49,317	34,055	48,294	99,955	0	99,955	99,955	99,955	50,637.12	102.67
5214002 - PERS - Extra Help	0	0	100	147	0	0	0	0	0	0.00	0.00

Object	2006 Adopted Budget	2006 Current Budget	2006 YTD Actuals	2006 Current Year Est.	2007 Dept Request	2007 Service Package	2007 Proposed Budget	2007 Base Budget	2007 Final Budget	Change in Budget	Pct Chg
5215000 - Insurance Premium Allowance	272,244	276,074	205,544	266,896	302,510	0	302,510	302,510	302,510	26,435.91	9.57
5220000 - Medicare	22,913	23,358	18,019	22,956	25,191	0	25,191	25,191	25,191	1,832.30	7.84
5221000 - Medicare - Extra Help	616	616	73	343	488	0	488	616	488	-128.00	-20.77
5230000 - Labor & Industries	12,086	12,593	8,042	12,086	18,090	0	18,090	18,090	18,090	5,498.07	43.65
5231000 - Labor & Industries-Extra Help	570	570	257	591	525	0	525	570	525	-45.00	-7.89
5310000 - Office Supplies	12,012	12,012	4,768	11,053	12,012	0	12,012	12,012	12,012	0.00	0.00
5320000 - Operating Supplies	5,467	5,467	1,662	3,389	5,467	0	5,467	5,467	5,467	0.00	0.00
5340000 - Supplies Packaged for Resale	0	0	0	0	0	0	0	0	0	0.00	0.00
5350000 - Small Tools/Minor Equipment	3,801	3,801	756	2,277	2,307	0	2,307	2,301	2,307	-1,494.00	-39.30
5360000 - Software/Upgrades/Licenses	4,105	4,105	94	1,100	2,425	0	2,425	4,105	2,425	-1,680.00	-40.92
5410000 - Professional Services	64,648	192,148	60,414	187,708	171,748	130,000	301,748	164,648	301,748	109,600.00	57.03
5420000 - Telephone	0	0	263	131	0	0	0	0	0	0.00	0.00
5425000 - Postage	13,546	13,546	47	13,546	13,546	0	13,546	13,546	13,546	0.00	0.00
5430000 - Travel(Lodge,meals,miles,Food)	12,354	12,354	8,455	11,693	13,013	0	13,013	12,354	13,013	659.00	5.33
5440000 - Advertising	20,000	20,000	21,244	25,150	20,000	0	20,000	20,000	20,000	0.00	0.00
5450000 - Operating Rentals & Lease	2,441	2,441	1,206	1,695	2,436	0	2,436	2,441	2,436	-5.00	-0.20
5480000 - Repairs & Maintenance	0	0	0	0	0	0	0	0	0	0.00	0.00
5491000 - Dues, Subscriptions	5,799	5,799	4,687	5,584	5,799	0	5,799	5,799	5,799	0.00	0.00
5492000 - Filing,Recording,Witness Fees	350	350	176	350	350	0	350	350	350	0.00	0.00
5493000 - Printing & Binding	11,030	11,030	699	5,315	11,030	0	11,030	11,030	11,030	0.00	0.00
5494000 - Registration/Training/Admissn	22,679	22,679	5,049	16,029	24,121	0	24,121	22,679	24,121	1,442.00	6.35
5510000 - Intergovt Professional Service	0	0	0	0	0	0	0	0	0	0.00	0.00
5640000 - Machinery & Equipment	0	0	0	0	0	0	0	0	0	0.00	0.00
5910000 - Interfund Chg-Equip Replacemnt	7,157	7,157	7,157	7,157	7,228	0	7,228	7,228	7,228	71.00	0.99
5950000 - Interfund Vehicle Operat/Maint	3,000	3,000	3,000	3,000	4,901	0	4,901	4,901	4,901	1,901.00	63.36
Total Expense Accounts:	2,271,239	2,436,798	1,667,474	2,290,797	2,626,866	130,000	2,756,866	2,628,867	2,756,866	320,067.22	13.13
Department 26 Economic Development											
<i>Expense Accounts</i>											
5110000 - Salaries	78,501	78,603	65,841	78,602	88,262	0	88,262	88,262	88,262	9,659.68	12.28
5111000 - Salaries-Extra Help	0	0	74	62	0	0	0	0	0	0.00	0.00
5210000 - Benefits	0	0	0	0	0	0	0	0	0	0.00	0.00
5212000 - Social Security Replace Progm	4,867	4,873	4,082	4,873	5,472	0	5,472	5,472	5,472	599.23	12.29
5213000 - Soc Sec Replace Pgm-Xtra Help	0	0	5	3	0	0	0	0	0	0.00	0.00
5214000 - PERS	2,406	2,409	1,884	2,409	5,064	0	5,064	5,064	5,064	2,655.03	110.21
5214002 - PERS - Extra Help	0	0	2	1	0	0	0	0	0	0.00	0.00
5215000 - Insurance Premium Allowance	9,192	9,192	7,273	9,192	9,492	0	9,492	9,492	9,492	300.36	3.26
5220000 - Medicare	1,138	1,139	999	1,139	1,280	0	1,280	1,280	1,280	140.54	12.33
5221000 - Medicare - Extra Help	0	0	1	1	0	0	0	0	0	0.00	0.00
5230000 - Labor & Industries	297	297	204	296	405	0	405	405	405	108.23	36.44
5231000 - Labor & Industries-Extra Help	0	0	1	1	0	0	0	0	0	0.00	0.00

Object	2006 Adopted Budget	2006 Current Budget	2006 YTD Actuals	2006 Current Year Est.	2007 Dept Request	2007 Service Package	2007 Proposed Budget	2007 Base Budget	2007 Final Budget	Change in Budget	Pct Chg
5310000 - Office Supplies	400	400	47	300	400	0	400	400	400	0.00	0.00
5320000 - Operating Supplies	350	350	107	350	350	0	350	350	350	0.00	0.00
5350000 - Small Tools/Minor Equipment	0	0	0	0	0	0	0	0	0	0.00	0.00
5360000 - Software/Upgrades/Licenses	0	0	0	0	0	0	0	0	0	0.00	0.00
5410000 - Professional Services	165,000	185,259	59,153	180,500	135,000	0	135,000	165,000	135,000	-50,259.00	-27.12
5425000 - Postage	400	400	1,897	2,000	400	0	400	400	400	0.00	0.00
5430000 - Travel(Lodge,meals,miles,Food)	3,299	3,299	1,777	3,299	4,000	0	4,000	3,299	4,000	701.00	21.24
5440000 - Advertising	250	250	4,200	5,000	250	0	250	250	250	0.00	0.00
5450000 - Operating Rentals & Lease	0	0	0	0	0	0	0	0	0	0.00	0.00
5491000 - Dues, Subscriptions	6,300	6,300	5,100	6,300	5,600	0	5,600	6,300	5,600	-700.00	-11.11
5493000 - Printing & Binding	550	550	34	550	550	0	550	550	550	0.00	0.00
5494000 - Registration/Training/Admissn	1,200	1,200	800	1,200	1,200	0	1,200	1,200	1,200	0.00	0.00
5495000 - City Grants to Other Agencies	0	0	0	0	0	0	0	0	0	0.00	0.00
5901000 - Interfund Prof Svc-Bld Permits	0	0	127	127	0	0	0	0	0	0.00	0.00
Total Expense Accounts:	274,150	294,521	153,608	296,205	257,725	0	257,725	287,724	257,725	-36,794.93	-12.49
Department 27 Public Works											
<i>Expense Accounts</i>											
5110000 - Salaries	352,053	356,575	282,694	356,575	375,581	0	375,581	375,581	375,581	19,006.37	5.33
5111000 - Salaries-Extra Help	32,291	32,291	26,838	32,291	32,291	0	32,291	32,291	32,291	0.00	0.00
5112000 - Overtime	12,021	12,021	16,160	16,896	20,541	0	20,541	15,574	20,541	8,520.00	70.87
5112100 - Overtime-Extra Help	0	0	0	0	0	0	0	0	0	0.00	0.00
5113000 - Standby Pay	0	0	1,068	804	0	0	0	0	0	0.00	0.00
5210000 - Benefits	0	0	0	0	0	0	0	0	0	0.00	0.00
5211000 - Benefits - Extra Help	0	0	0	0	0	0	0	0	0	0.00	0.00
5212000 - Social Security Replace Progm	21,827	22,110	18,572	22,109	23,286	0	23,286	23,286	23,286	1,175.95	5.31
5213000 - Soc Sec Replace Pgm-Xtra Help	2,005	2,005	1,686	2,005	2,001	0	2,001	2,001	2,001	-4.00	-0.19
5214000 - PERS	10,790	10,930	8,514	10,803	21,545	0	21,545	21,545	21,545	10,613.99	97.10
5214002 - PERS - Extra Help	750	750	716	865	1,521	0	1,521	1,521	1,521	771.00	102.80
5215000 - Insurance Premium Allowance	45,572	45,572	37,104	45,572	49,669	0	49,669	49,669	49,669	4,096.74	8.98
5220000 - Medicare	5,105	5,173	4,599	5,112	5,446	0	5,446	5,446	5,446	273.85	5.29
5221000 - Medicare - Extra Help	498	498	394	492	469	0	469	469	469	-29.00	-5.82
5230000 - Labor & Industries	3,952	3,952	3,227	3,951	5,534	0	5,534	5,534	5,534	1,583.39	40.06
5231000 - Labor & Industries-Extra Help	1,040	1,040	1,016	1,181	1,097	0	1,097	1,097	1,097	57.00	5.48
5310000 - Office Supplies	3,350	3,350	1,263	2,716	3,150	0	3,150	3,150	3,150	-200.00	-5.97
5320000 - Operating Supplies	45,250	45,250	18,838	43,250	43,180	0	43,180	43,250	43,180	-2,070.00	-4.57
5321000 - Fuel Consumed	1,500	1,500	0	1,500	1,500	0	1,500	1,500	1,500	0.00	0.00
5330000 - Program Supplies	24,500	24,500	14,267	37,238	11,242	0	11,242	11,279	11,242	-13,258.00	-54.11
5350000 - Small Tools/Minor Equipment	8,500	8,500	8,498	9,600	8,500	0	8,500	8,500	8,500	0.00	0.00
5360000 - Software/Upgrades/Licenses	8,200	8,200	8,124	8,319	9,200	0	9,200	8,200	9,200	1,000.00	12.19
5410000 - Professional Services	120,412	126,515	37,139	181,266	89,588	0	89,588	91,649	89,588	-36,927.48	-29.18

Object	2006 Adopted Budget	2006 Current Budget	2006 YTD Actuals	2006 Current Year Est.	2007 Dept Request	2007 Service Package	2007 Proposed Budget	2007 Base Budget	2007 Final Budget	Change in Budget	Pct Chg
5420000 - Telephone	0	0	1,051	1,326	0	0	0	0	0	0.00	0.00
5425000 - Postage	18,180	22,530	8,996	23,246	13,896	0	13,896	13,896	13,896	-8,634.00	-38.32
5430000 - Travel(Lodge,meals,miles,Food)	11,500	11,500	1,485	9,459	12,000	0	12,000	11,500	12,000	500.00	4.34
5440000 - Advertising	0	0	0	0	0	0	0	0	0	0.00	0.00
5450000 - Operating Rentals & Lease	611,800	621,500	464,736	621,500	315,562	0	315,562	315,562	315,562	-305,938.00	-49.22
5471000 - Utility-Electricity	13,956	13,956	10,556	13,956	13,956	0	13,956	13,956	13,956	0.00	0.00
5472000 - Utility-Water	0	0	0	0	0	0	0	0	0	0.00	0.00
5473000 - Utility-Gas	2,320	2,320	2,381	3,368	3,368	0	3,368	2,320	3,368	1,048.00	45.17
5474000 - UTILITY-SEWER	0	0	330	900	0	0	0	0	0	0.00	0.00
5475000 - UTILITY-GARBAGE/SOLID WAS.	5,500	5,500	0	1,302	4,452	0	4,452	5,500	4,452	-1,048.00	-19.05
5480000 - Repairs & Maintenance	97,519	97,519	49,245	95,349	92,795	0	92,795	97,519	92,795	-4,724.00	-4.84
5491000 - Dues, Subscriptions	3,500	3,500	1,034	3,505	3,500	0	3,500	3,500	3,500	0.00	0.00
5493000 - Printing & Binding	9,400	9,400	10,652	23,342	15,345	0	15,345	17,088	15,345	5,945.00	63.24
5494000 - Registration/Training/Admissn	5,800	5,800	1,860	5,600	5,725	0	5,725	5,725	5,725	-75.00	-1.29
5495000 - City Grants to Other Agencies	0	0	0	0	5,000	0	5,000	5,000	5,000	5,000.00	0.00
5499000 - Miscellaneous Expenses	0	0	0	0	0	0	0	0	0	0.00	0.00
5510000 - Intergovt Professional Service	7,500	7,500	270	7,500	7,500	0	7,500	7,500	7,500	0.00	0.00
5620000 - Buildings & Structures	0	0	0	0	0	0	0	0	0	0.00	0.00
5630000 - Other Improvements	0	0	0	0	0	0	0	0	0	0.00	0.00
5640000 - Machinery & Equipment	0	0	0	0	0	0	0	0	0	0.00	0.00
5650000 - Construction of Fixed Assets	0	0	0	0	0	0	0	0	0	0.00	0.00
5700000 - Debt Service-Principal	0	0	0	0	0	0	0	0	0	0.00	0.00
5800000 - Debt Service-Interest	0	0	0	0	0	0	0	0	0	0.00	0.00
5901000 - Interfund Prof Svc-Bld Permits	1,000	1,000	0	1,000	1,000	0	1,000	1,000	1,000	0.00	0.00
5910000 - Interfund Chg-Equip Replacemnt	9,776	9,776	9,776	9,776	8,263	0	8,263	8,263	8,263	-1,513.00	-15.47
5950000 - Interfund Vehicle Operat/Maint	6,321	6,321	6,321	6,321	4,708	0	4,708	4,708	4,708	-1,613.00	-25.51
5992000 - Contingency	0	0	0	0	0	0	0	0	0	0.00	0.00
5993000 - COLA Contingency	0	0	0	0	0	0	0	0	0	0.00	0.00
Total Expense Accounts:	1,503,688	1,528,854	1,059,410	1,609,995	1,212,411	0	1,212,411	1,214,579	1,212,411	-316,442.19	-20.69
Total General Fund:	29,091,217	29,398,166	19,589,214	29,317,275	28,288,243	138,736	28,426,981	28,069,764	28,426,981	-971,180.54	-3.30
Department 27 Public Works											
<i>TRANSFER OUT ACCOUNTS</i>											
5970000 - Operating Transfers Out	760,131	760,131	380,066	760,131	530,176	0	530,176	760,131	530,176	-229,955.00	-30.25
Total TRANSFER OUT ACCOUNTS:	760,131	760,131	380,066	760,131	530,176	0	530,176	760,131	530,176	-229,955.00	-30.25
<i>Expense Accounts</i>											
5110000 - Salaries	613,551	613,551	457,498	571,873	643,479	0	643,479	643,479	643,479	29,928.19	4.87
5111000 - Salaries-Extra Help	32,343	32,343	20,498	41,978	33,606	0	33,606	32,343	33,606	1,263.00	3.90
5112000 - Overtime	13,000	13,000	7,482	13,000	13,000	0	13,000	13,000	13,000	0.00	0.00
5112100 - Overtime-Extra Help	0	0	120	120	0	0	0	0	0	0.00	0.00
5113000 - Standby Pay	500	500	2,979	2,587	500	0	500	500	500	0.00	0.00

Comparative Budget Worksheet By Object

Object	2006 Adopted Budget	2006 Current Budget	2006 YTD Actuals	2006 Current Year Est.	2007 Dept Request	2007 Service Package	2007 Proposed Budget	2007 Base Budget	2007 Final Budget	Change in Budget	Pct Chg
5114000 - Callback Pay	1,000	1,000	3,343	4,000	5,724	0	5,724	1,000	5,724	4,724.00	472.40
5210000 - Benefits	0	0	0	0	0	0	0	0	0	0.00	0.00
5211000 - Benefits - Extra Help	0	0	0	0	0	0	0	0	0	0.00	0.00
5212000 - Social Security Replace Progm	38,040	38,040	29,197	35,457	39,896	0	39,896	39,896	39,896	1,855.54	4.87
5213000 - Soc Sec Replace Pgm-Xtra Help	2,005	2,005	1,278	2,610	2,083	0	2,083	2,083	2,083	78.00	3.89
5214000 - PERS	18,805	18,805	13,260	14,451	36,920	0	36,920	36,920	36,920	18,115.03	96.33
5214002 - PERS - Extra Help	0	0	0	0	0	0	0	0	0	0.00	0.00
5215000 - Insurance Premium Allowance	112,121	112,121	83,330	111,456	124,332	0	124,332	124,332	124,332	12,211.57	10.89
5220000 - Medicare	8,896	8,896	7,287	8,292	9,331	0	9,331	9,331	9,331	433.95	4.87
5221000 - Medicare - Extra Help	2,948	2,948	299	3,090	487	0	487	487	487	-2,461.00	-83.48
5230000 - Labor & Industries	13,695	13,695	10,661	12,717	18,595	0	18,595	18,595	18,595	4,900.24	35.78
5231000 - Labor & Industries-Extra Help	2,016	2,016	683	2,216	2,219	0	2,219	2,219	2,219	203.00	10.06
5310000 - Office Supplies	2,500	2,500	795	2,500	2,000	0	2,000	2,500	2,000	-500.00	-20.00
5320000 - Operating Supplies	62,600	62,600	55,044	97,029	104,500	6,300	110,800	62,600	110,800	48,200.00	77.00
5330000 - Program Supplies	1,000	1,000	0	1,000	0	0	0	1,000	0	-1,000.00	-100.00
5350000 - Small Tools/Minor Equipment	8,769	8,769	3,335	7,300	6,000	0	6,000	8,769	6,000	-2,769.00	-31.57
5360000 - Software/Upgrades/Licenses	0	0	5,272	5,472	5,000	0	5,000	0	5,000	5,000.00	0.00
5410000 - Professional Services	51,673	80,479	8,838	39,973	39,873	0	39,873	51,673	39,873	-40,606.00	-50.45
5420000 - Telephone	0	0	465	1,067	0	0	0	0	0	0.00	0.00
5425000 - Postage	200	200	45	216	200	0	200	200	200	0.00	0.00
5430000 - Travel(Lodge,meals,miles,Food)	4,900	4,900	3,735	7,880	4,900	0	4,900	4,900	4,900	0.00	0.00
5450000 - Operating Rentals & Lease	12,500	12,500	457	12,500	12,500	0	12,500	12,500	12,500	0.00	0.00
5471000 - Utility-Electricity	0	0	2,753	3,474	0	0	0	0	0	0.00	0.00
5471001 - Utility-Electricity,Street Lts	183,500	183,500	69,976	183,500	183,500	0	183,500	183,500	183,500	0.00	0.00
5471002 - Utility-Electricity,Traffic Sg	30,727	30,727	32,969	37,183	40,000	0	40,000	30,727	40,000	9,273.00	30.17
5472000 - Utility-Water	0	0	398	500	0	0	0	0	0	0.00	0.00
5480000 - Repairs & Maintenance	172,750	172,750	76,911	122,153	174,188	0	174,188	267,175	174,188	1,438.00	0.83
5491000 - Dues, Subscriptions	2,250	2,250	239	2,274	1,350	0	1,350	2,250	1,350	-900.00	-40.00
5493000 - Printing & Binding	100	100	58	158	100	0	100	100	100	0.00	0.00
5494000 - Registration/Training/Admissn	9,477	9,477	3,715	11,017	9,477	0	9,477	9,477	9,477	0.00	0.00
5495000 - City Grants to Other Agencies	0	0	0	0	0	0	0	0	0	0.00	0.00
5510000 - Intergovt Professional Service	234,683	295,651	110,954	312,034	220,601	-50,661	169,940	234,683	169,940	-125,711.00	-42.52
5630000 - Other Improvements	0	0	0	0	0	0	0	0	0	0.00	0.00
5640000 - Machinery & Equipment	0	0	3,132	10,000	0	90,000	90,000	0	90,000	90,000.00	0.00
5901000 - Interfund Prof Svc-Bld Permits	0	0	157	157	0	0	0	0	0	0.00	0.00
5910000 - Interfund Chg-Equip Replacemnt	43,839	43,839	43,839	43,839	42,681	13,125	55,806	42,681	55,806	11,967.00	27.29
5950000 - Interfund Vehicle Operat/Maint	28,352	28,352	28,352	28,352	48,905	7,200	56,105	48,905	56,105	27,753.00	97.88
5992000 - Contingency	0	0	0	0	0	0	0	0	0	0.00	0.00
5993000 - COLA Contingency	1,006	1,006	0	0	0	0	0	0	0	-1,006.00	-100.00
Total Expense Accounts:	1,709,746	1,799,520	1,089,354	1,753,425	1,825,947	65,964	1,891,911	1,887,825	1,891,911	92,390.52	5.13

Object	2006 Adopted Budget	2006 Current Budget	2006 YTD Actuals	2006 Current Year Est.	2007 Dept Request	2007 Service Package	2007 Proposed Budget	2007 Base Budget	2007 Final Budget	Change in Budget	Pct Chg
Total Street Fund:	2,469,877	2,559,651	1,469,420	2,513,556	2,356,123	65,964	2,422,087	2,647,956	2,422,087	-137,564.48	-5.37
Department 25 Planning & Development Sv											
<i>Expense Accounts</i>											
5320000 - Operating Supplies	0	0	0	0	0	0	0	0	0	0.00	0.00
5410000 - Professional Services	100,000	100,000	413	99,530	100,000	0	100,000	100,000	100,000	0.00	0.00
5425000 - Postage	0	0	0	0	0	0	0	0	0	0.00	0.00
5440000 - Advertising	0	0	0	0	0	0	0	0	0	0.00	0.00
5480000 - Repairs & Maintenance	0	0	470	470	0	0	0	0	0	0.00	0.00
5630000 - Other Improvements	0	0	0	0	0	0	0	0	0	0.00	0.00
5901000 - Interfund Prof Svc-Bld Permits	0	0	0	0	0	0	0	0	0	0.00	0.00
Total Expense Accounts:	100,000	100,000	883	100,000	100,000	0	100,000	100,000	100,000	0.00	0.00
Total Code Abatement Fund:	100,000	100,000	883	100,000	100,000	0	100,000	100,000	100,000	0.00	0.00
Department 20 Police											
<i>Expense Accounts</i>											
5350000 - Small Tools/Minor Equipment	23,000	23,000	1,571	2,694	23,500	0	23,500	23,000	23,500	500.00	2.17
5360000 - Software/Upgrades/Licenses	0	0	0	0	0	0	0	0	0	0.00	0.00
5410000 - Professional Services	0	0	0	0	0	0	0	0	0	0.00	0.00
5430000 - Travel(Lodge,meals,miles,Food)	0	0	3,735	2,000	0	0	0	0	0	0.00	0.00
5494000 - Registration/Training/Admissn	0	0	2,739	2,000	0	0	0	0	0	0.00	0.00
5640000 - Machinery & Equipment	0	0	0	0	0	0	0	0	0	0.00	0.00
Total Expense Accounts:	23,000	23,000	8,045	6,694	23,500	0	23,500	23,000	23,500	500.00	2.17
Total Asset Seizure Fund:	23,000	23,000	8,045	6,694	23,500	0	23,500	23,000	23,500	500.00	2.17
Department 24 Parks, Recreation, Cultural S											
<i>Expense Accounts</i>											
5410000 - Professional Services	0	0	0	0	0	0	0	0	0	0.00	0.00
5630000 - Other Improvements	0	115,775	23,132	115,775	0	0	0	0	0	-115,775.00	-100.00
Total Expense Accounts:	0	115,775	23,132	115,775	0	0	0	0	0	-115,775.00	-100.00
Total Public Arts Fund:	0	115,775	23,132	115,775	0	0	0	0	0	-115,775.00	-100.00
Department 28 General Government CIP											
<i>TRANSFER OUT ACCOUNTS</i>											
5970000 - Operating Transfers Out	39,797	39,797	19,899	39,797	33,754	0	33,754	39,797	33,754	-6,043.00	-15.18
Total TRANSFER OUT ACCOUNTS:	39,797	39,797	19,899	39,797	33,754	0	33,754	39,797	33,754	-6,043.00	-15.18
<i>Expense Accounts</i>											
5110000 - Salaries	90,968	90,968	65,974	109,870	161,175	0	161,175	161,175	161,175	70,208.21	77.17
5111000 - Salaries-Extra Help	3,753	3,753	44	3,753	3,759	0	3,759	3,753	3,759	6.00	0.15
5112000 - Overtime	500	500	151	206	0	0	0	500	0	-500.00	-100.00
5210000 - Benefits	0	0	0	0	0	0	0	0	0	0.00	0.00
5211000 - Benefits - Extra Help	0	0	0	0	0	0	0	0	0	0.00	0.00

Object	2006 Adopted Budget	2006 Current Budget	2006 YTD Actuals	2006 Current Year Est.	2007 Dept Request	2007 Service Package	2007 Proposed Budget	2007 Base Budget	2007 Final Budget	Change in Budget	Pct Chg
5212000 - Social Security Replace Progm	5,640	5,640	4,042	6,789	9,994	0	9,994	9,994	9,994	4,352.91	77.17
5213000 - Soc Sec Replace Pgm-Xtra Help	301	301	3	301	301	0	301	301	301	0.00	0.00
5214000 - PERS	2,788	2,788	1,929	3,324	9,247	0	9,247	9,247	9,247	6,457.65	231.62
5214002 - PERS - Extra Help	0	0	1	0	0	0	0	0	0	0.00	0.00
5215000 - Insurance Premium Allowance	13,976	13,976	10,753	16,698	24,708	0	24,708	24,708	24,708	10,732.04	76.78
5220000 - Medicare	1,319	1,319	995	1,605	2,338	0	2,338	2,338	2,338	1,018.03	77.18
5221000 - Medicare - Extra Help	70	70	1	70	70	0	70	70	70	0.00	0.00
5230000 - Labor & Industries	967	967	479	591	1,732	0	1,732	1,732	1,732	765.72	79.18
5231000 - Labor & Industries-Extra Help	69	69	1	69	69	0	69	69	69	0.00	0.00
5310000 - Office Supplies	0	0	466	385	750	0	750	0	750	750.00	0.00
5320000 - Operating Supplies	1,000	1,000	10,564	4,210	0	0	0	1,000	0	-1,000.00	-100.00
5350000 - Small Tools/Minor Equipment	800	800	7,882	7,789	500	0	500	800	500	-300.00	-37.50
5360000 - Software/Upgrades/Licenses	0	0	0	0	0	0	0	0	0	0.00	0.00
5410000 - Professional Services	1,059,189	1,464,294	129,167	1,024,518	765,434	0	765,434	1,059,189	765,434	-698,860.00	-47.72
5420000 - Telephone	0	0	88	100	0	0	0	0	0	0.00	0.00
5425000 - Postage	0	0	1,095	1,168	0	0	0	0	0	0.00	0.00
5430000 - Travel(Lodge,meals,miles,Food)	1,206	1,206	1,337	1,049	1,000	0	1,000	1,206	1,000	-206.00	-17.08
5440000 - Advertising	0	0	0	0	0	0	0	0	0	0.00	0.00
5450000 - Operating Rentals & Lease	0	0	388	400	0	0	0	0	0	0.00	0.00
5480000 - Repairs & Maintenance	0	0	724	724	0	0	0	0	0	0.00	0.00
5491000 - Dues, Subscriptions	0	0	279	300	0	0	0	0	0	0.00	0.00
5493000 - Printing & Binding	0	0	1,025	1,013	0	0	0	0	0	0.00	0.00
5494000 - Registration/Training/Admissn	1,300	1,300	581	1,300	1,000	0	1,000	1,300	1,000	-300.00	-23.07
5510000 - Intergovt Professional Service	0	65,430	0	20,000	0	0	0	0	0	-65,430.00	-100.00
5610000 - Land	10,480,000	10,480,000	568,221	10,963,302	158,050	0	158,050	10,480,000	158,050	-10,321,950.00	-98.49
5620000 - Buildings & Structures	0	0	0	9,050,000	175,000	0	175,000	0	175,000	175,000.00	0.00
5630000 - Other Improvements	1,947,500	6,774,145	1,231,386	1,684,189	3,926,592	0	3,926,592	1,947,500	3,926,592	-2,847,553.00	-42.03
5640000 - Machinery & Equipment	0	350	0	350	15,000	0	15,000	0	15,000	14,650.00	4,185.71
5650000 - Construction of Fixed Assets	0	0	0	0	18,400,000	0	18,400,000	0	18,400,000	18,400,000.00	0.00
5910000 - Interfund Chg-Equip Replacemnt	1,474	1,474	1,474	1,474	0	0	0	0	0	-1,474.00	-100.00
5950000 - Interfund Vehicle Operat/Maint	1,000	1,000	1,000	1,000	750	0	750	750	750	-250.00	-25.00
5992000 - Contingency	0	0	0	0	0	0	0	0	0	0.00	0.00
5993000 - COLA Contingency	313	313	0	0	0	0	0	313	0	-313.00	-100.00
Total Expense Accounts:	13,614,133	18,911,663	2,040,050	22,906,547	23,657,469	0	23,657,469	13,705,945	23,657,469	4,745,804.56	25.09
Total Capital Improvement Fund:	13,653,930	18,951,460	2,059,949	22,946,344	23,691,223	0	23,691,223	13,745,742	23,691,223	4,739,761.56	25.01
Department 31 Facility Major Maintenance I											
<i>Expense Accounts</i>											
5480000 - Repairs & Maintenance	0	0	0	0	0	0	0	0	0	0.00	0.00
5620000 - Buildings & Structures	0	0	30,203	45,000	0	0	0	0	0	0.00	0.00
5630000 - Other Improvements	60,000	60,000	7,226	15,000	110,000	0	110,000	60,000	110,000	50,000.00	83.33

Object	2006 Adopted Budget	2006 Current Budget	2006 YTD Actuals	2006 Current Year Est.	2007 Dept Request	2007 Service Package	2007 Proposed Budget	2007 Base Budget	2007 Final Budget	Change in Budget	Pct Chg
Total Expense Accounts:	60,000	60,000	37,429	60,000	110,000	0	110,000	60,000	110,000	50,000.00	83.33
Total City Facility-Major Maint Fund:	60,000	60,000	37,429	60,000	110,000	0	110,000	60,000	110,000	50,000.00	83.33
Department 29 Roads Capital Improvements											
<i>TRANSFER OUT ACCOUNTS</i>											
5970000 - Operating Transfers Out	56,120	56,120	28,060	56,120	55,680	0	55,680	56,120	55,680	-440.00	-0.78
Total TRANSFER OUT ACCOUNTS:	56,120	56,120	28,060	56,120	55,680	0	55,680	56,120	55,680	-440.00	-0.78
<i>Expense Accounts</i>											
5110000 - Salaries	708,625	708,625	664,614	754,048	703,138	0	703,138	703,138	703,138	-5,487.92	-0.77
5111000 - Salaries-Extra Help	3,455	3,455	19,861	19,187	3,455	0	3,455	3,455	3,455	0.00	0.00
5112000 - Overtime	0	0	2,497	2,259	0	0	0	0	0	0.00	0.00
5112100 - Overtime-Extra Help	0	0	195	195	0	0	0	0	0	0.00	0.00
5113000 - Standby Pay	0	0	98	100	0	0	0	0	0	0.00	0.00
5212000 - Social Security Replace Progrm	43,935	43,935	40,301	46,521	43,593	0	43,593	43,593	43,593	-340.25	-0.77
5213000 - Soc Sec Replace Pgm-Xtra Help	236	236	1,244	1,222	236	0	236	236	236	0.00	0.00
5214000 - PERS	21,718	21,718	18,909	22,679	40,338	0	40,338	40,338	40,338	18,618.78	85.72
5214002 - PERS - Extra Help	0	0	345	267	0	0	0	0	0	0.00	0.00
5215000 - Insurance Premium Allowance	103,849	103,849	94,748	111,132	105,152	0	105,152	105,152	105,152	1,303.00	1.25
5220000 - Medicare	10,276	10,276	9,846	10,819	10,197	0	10,197	10,197	10,197	-79.56	-0.77
5221000 - Medicare - Extra Help	55	55	291	285	55	0	55	55	55	0.00	0.00
5230000 - Labor & Industries	4,217	4,217	4,120	4,610	5,836	0	5,836	5,836	5,836	1,618.25	38.37
5231000 - Labor & Industries-Extra Help	54	54	1,001	885	54	0	54	54	54	0.00	0.00
5310000 - Office Supplies	2,511	2,511	2,137	3,661	1,045	0	1,045	2,511	1,045	-1,466.00	-58.38
5320000 - Operating Supplies	2,000	2,000	24,154	24,904	0	0	0	2,000	0	-2,000.00	-100.00
5330000 - Program Supplies	500	500	1,664	2,164	0	0	0	500	0	-500.00	-100.00
5350000 - Small Tools/Minor Equipment	250	250	17,100	17,085	250	0	250	250	250	0.00	0.00
5360000 - Software/Upgrades/Licenses	1,000	1,000	188	1,094	0	0	0	1,000	0	-1,000.00	-100.00
5410000 - Professional Services	2,738,473	4,207,508	1,728,580	2,855,150	1,355,900	0	1,355,900	2,738,473	1,355,900	-2,851,608.00	-67.77
5420000 - Telephone	0	0	351	362	0	0	0	0	0	0.00	0.00
5425000 - Postage	10,476	10,476	6,497	16,259	0	0	0	10,476	0	-10,476.00	-100.00
5430000 - Travel(Lodge,meals,miles,Food)	2,200	2,200	2,491	3,642	1,150	0	1,150	2,200	1,150	-1,050.00	-47.72
5440000 - Advertising	0	0	9,799	8,978	0	0	0	0	0	0.00	0.00
5450000 - Operating Rentals & Lease	11,446	11,446	23,791	22,877	0	0	0	11,446	0	-11,446.00	-100.00
5471002 - Utility-Electricity,Traffic Sg	0	0	379	379	0	0	0	0	0	0.00	0.00
5472000 - Utility-Water	0	0	14,596	12,682	0	0	0	0	0	0.00	0.00
5474000 - UTILITY-SEWER	0	0	50	50	0	0	0	0	0	0.00	0.00
5480000 - Repairs & Maintenance	150,000	150,000	1,092	151,092	153,000	0	153,000	150,000	153,000	3,000.00	2.00
5491000 - Dues, Subscriptions	820	820	1,175	1,654	820	0	820	820	820	0.00	0.00
5492000 - Filing,Recording,Witness Fees	0	0	84	84	0	0	0	0	0	0.00	0.00
5493000 - Printing & Binding	400	400	5,307	4,269	0	0	0	400	0	-400.00	-100.00
5494000 - Registration/Training/Admissn	3,836	3,836	1,772	6,546	36	0	36	3,836	36	-3,800.00	-99.06

Object	2006 Adopted Budget	2006 Current Budget	2006 YTD Actuals	2006 Current Year Est.	2007 Dept Request	2007 Service Package	2007 Proposed Budget	2007 Base Budget	2007 Final Budget	Change in Budget	Pct Chg
5499000 - Miscellaneous Expenses	0	0	10	5	0	0	0	0	0	0.00	0.00
5510000 - Intergovt Professional Service	1,533	1,533	55,353	50,636	2,000	0	2,000	1,533	2,000	467.00	30.46
5610000 - Land	505,000	505,000	213,545	255,451	274,000	0	274,000	505,000	274,000	-231,000.00	-45.74
5620000 - Buildings & Structures	2,034	2,034	0	202,034	1,933,245	0	1,933,245	2,034	1,933,245	1,931,211.00	94,946.46
5630000 - Other Improvements	21,536,529	27,139,297	14,864,924	26,678,534	765,731	0	765,731	21,536,529	765,731	-26,373,566.00	-97.17
5640000 - Machinery & Equipment	0	0	0	0	0	0	0	0	0	0.00	0.00
5650000 - Construction of Fixed Assets	1,491,594	1,491,594	4,770	2,035,578	1,777,948	0	1,777,948	1,491,594	1,777,948	286,354.00	19.19
5901000 - Interfund Prof Svc-Bld Permits	0	0	640	640	387	0	387	0	387	387.00	0.00
5910000 - Interfund Chg-Equip Replacemnt	387	387	387	387	0	0	0	387	0	-387.00	-100.00
5950000 - Interfund Vehicle Operat/Maint	352	352	352	352	188	0	188	188	188	-164.00	-46.59
5992000 - Contingency	0	0	0	0	0	0	0	0	0	0.00	0.00
5993000 - COLA Contingency	3,235	3,235	0	0	0	0	0	3,235	0	-3,235.00	-100.00
Total Expense Accounts:	<u>27,360,996</u>	<u>34,432,799</u>	<u>17,839,258</u>	<u>33,330,758</u>	<u>7,177,754</u>	<u>0</u>	<u>7,177,754</u>	<u>27,376,466</u>	<u>7,177,754</u>	<u>-27,255,046.70</u>	<u>-79.15</u>
Total Roads Capital Fund:	<u>27,417,116</u>	<u>34,488,919</u>	<u>17,867,318</u>	<u>33,386,878</u>	<u>7,233,434</u>	<u>0</u>	<u>7,233,434</u>	<u>27,432,586</u>	<u>7,233,434</u>	<u>-27,255,486.70</u>	<u>-79.02</u>
Department 27 Public Works											
<i>TRANSFER OUT ACCOUNTS</i>											
5970000 - Operating Transfers Out	3,424,862	3,424,862	0	0	0	0	0	1,024,862	0	-3,424,862.00	-100.00
Total TRANSFER OUT ACCOUNTS:	<u>3,424,862</u>	<u>3,424,862</u>	<u>0</u>	<u>0</u>	<u>0</u>	<u>0</u>	<u>0</u>	<u>1,024,862</u>	<u>0</u>	<u>-3,424,862.00</u>	<u>-100.00</u>
<i>Expense Accounts</i>											
5110000 - Salaries	384,292	384,292	270,956	343,106	397,572	0	397,572	397,572	397,572	13,280.56	3.45
5111000 - Salaries-Extra Help	29,828	29,828	23,741	22,396	30,181	0	30,181	34,828	30,181	353.00	1.18
5112000 - Overtime	7,985	7,985	4,620	4,897	7,985	0	7,985	7,985	7,985	0.00	0.00
5112100 - Overtime-Extra Help	0	0	347	373	0	0	0	0	0	0.00	0.00
5113000 - Standby Pay	100	100	4,609	4,364	5,824	0	5,824	100	5,824	5,724.00	5,724.00
5114000 - Callback Pay	300	300	999	1,200	3,435	0	3,435	300	3,435	3,135.00	1,045.00
5210000 - Benefits	0	0	0	0	0	0	0	0	0	0.00	0.00
5211000 - Benefits - Extra Help	0	0	0	0	0	0	0	0	0	0.00	0.00
5212000 - Social Security Replacm Progm	23,826	23,826	17,385	21,272	24,650	0	24,650	24,650	24,650	823.38	3.45
5213000 - Soc Sec Replac Pgm-Xtra Help	1,849	1,849	1,528	1,428	1,872	0	1,872	1,849	1,872	23.00	1.24
5214000 - PERS	11,778	11,778	7,998	8,372	22,811	0	22,811	22,811	22,811	11,032.31	93.66
5214002 - PERS - Extra Help	0	0	90	110	740	0	740	740	740	740.00	0.00
5215000 - Insurance Premium Allowance	62,522	62,522	42,888	59,217	65,740	0	65,740	65,740	65,740	3,218.18	5.14
5220000 - Medicare	5,572	5,572	4,386	4,975	5,764	0	5,764	5,764	5,764	192.57	3.45
5221000 - Medicare - Extra Help	435	435	358	334	438	0	438	435	438	3.00	0.68
5230000 - Labor & Industries	7,004	7,004	5,520	6,303	9,462	0	9,462	9,462	9,462	2,458.80	35.10
5231000 - Labor & Industries-Extra Help	1,716	1,716	1,455	1,358	2,974	0	2,974	1,788	2,974	1,258.00	73.31
5310000 - Office Supplies	750	750	646	880	800	0	800	750	800	50.00	6.66
5320000 - Operating Supplies	45,960	45,960	45,763	45,678	62,723	4,200	66,923	44,960	66,923	20,963.00	45.61
5321000 - Fuel Consumed	0	0	0	0	0	0	0	0	0	0.00	0.00
5330000 - Program Supplies	26,000	26,000	18,641	44,725	2,000	0	2,000	2,000	2,000	-24,000.00	-92.30

Object	2006 Adopted Budget	2006 Current Budget	2006 YTD Actuals	2006 Current Year Est.	2007 Dept Request	2007 Service Package	2007 Proposed Budget	2007 Base Budget	2007 Final Budget	Change in Budget	Pct Chg
5350000 - Small Tools/Minor Equipment	8,000	8,000	6,353	5,463	7,000	0	7,000	7,000	7,000	-1,000.00	-12.50
5360000 - Software/Upgrades/Licenses	0	0	31	31	0	0	0	0	0	0.00	0.00
5410000 - Professional Services	101,654	134,606	29,647	91,600	65,229	0	65,229	85,229	65,229	-69,377.00	-51.54
5420000 - Telephone	0	0	323	723	0	0	0	0	0	0.00	0.00
5425000 - Postage	10,368	20,868	0	9,000	10,368	0	10,368	10,368	10,368	-10,500.00	-50.31
5430000 - Travel(Lodge,meals,miles,Food)	1,984	1,984	-265	1,456	1,984	0	1,984	1,984	1,984	0.00	0.00
5450000 - Operating Rentals & Lease	9,000	9,000	8,484	8,892	9,000	0	9,000	9,000	9,000	0.00	0.00
5471000 - Utility-Electricity	500	500	258	223	500	0	500	500	500	0.00	0.00
5480000 - Repairs & Maintenance	167,949	167,949	84,446	207,960	221,090	-24,000	197,090	224,949	197,090	29,141.00	17.35
5491000 - Dues, Subscriptions	730	730	1,060	812	730	0	730	730	730	0.00	0.00
5493000 - Printing & Binding	7,200	15,200	0	14,000	7,200	0	7,200	7,200	7,200	-8,000.00	-52.63
5494000 - Registration/Training/Admissn	6,294	6,294	1,208	4,150	6,294	0	6,294	6,294	6,294	0.00	0.00
5510000 - Intergovt Professional Service	267,829	374,683	57,145	373,509	268,374	0	268,374	267,829	268,374	-106,309.00	-28.37
5630000 - Other Improvements	0	22,545	0	0	0	0	0	0	0	-22,545.00	-100.00
5640000 - Machinery & Equipment	0	0	0	0	0	60,000	60,000	0	60,000	60,000.00	0.00
5700000 - Debt Service-Principal	319,944	319,944	319,943	319,944	326,475	0	326,475	319,944	326,475	6,531.00	2.04
5800000 - Debt Service-Interest	25,506	25,506	25,595	25,595	24,425	0	24,425	25,506	24,425	-1,081.00	-4.23
5910000 - Interfund Chg-Equip Replacemnt	11,167	11,167	11,167	11,167	12,354	8,750	21,104	12,354	21,104	9,937.00	88.98
5950000 - Interfund Vehicle Operat/Maint	7,701	7,701	7,701	7,701	13,122	4,800	17,922	13,122	17,922	10,221.00	132.72
5993000 - COLA Contingency	1,511	1,511	0	0	0	0	0	0	0	-1,511.00	-100.00
Total Expense Accounts:	1,557,254	1,738,105	1,005,026	1,653,214	1,619,116	53,750	1,672,866	1,613,743	1,672,866	-65,238.20	-3.75
Department 30 Surface Water CIP											
<i>TRANSFER OUT ACCOUNTS</i>											
5970000 - Operating Transfers Out	82,812	82,812	1,753,837	82,812	426,837	0	426,837	82,812	426,837	344,025.00	415.42
Total TRANSFER OUT ACCOUNTS:	82,812	82,812	1,753,837	82,812	426,837	0	426,837	82,812	426,837	344,025.00	415.42
<i>Expense Accounts</i>											
5110000 - Salaries	210,352	210,352	84,904	192,992	251,476	0	251,476	251,476	251,476	41,122.97	19.54
5111000 - Salaries-Extra Help	4,809	4,809	1,598	4,809	4,809	0	4,809	4,809	4,809	0.00	0.00
5112000 - Overtime	0	0	1,618	1,400	0	0	0	0	0	0.00	0.00
5113000 - Standby Pay	0	0	244	300	0	0	0	0	0	0.00	0.00
5212000 - Social Security Replace Progrm	13,041	13,041	5,292	11,922	15,591	0	15,591	15,591	15,591	2,549.62	19.55
5213000 - Soc Sec Replace Pgm-Xtra Help	422	422	99	422	422	0	422	422	422	0.00	0.00
5214000 - PERS	6,448	6,448	2,445	5,884	14,425	0	14,425	14,425	14,425	7,978.70	123.73
5215000 - Insurance Premium Allowance	31,824	31,824	12,885	29,099	33,328	0	33,328	33,328	33,328	1,504.84	4.72
5220000 - Medicare	3,051	3,051	1,303	2,791	3,648	0	3,648	3,648	3,648	596.28	19.54
5221000 - Medicare - Extra Help	99	99	23	99	99	0	99	99	99	0.00	0.00
5230000 - Labor & Industries	2,336	2,336	819	2,259	2,606	0	2,606	2,606	2,606	269.95	11.55
5231000 - Labor & Industries-Extra Help	97	97	94	97	97	0	97	97	97	0.00	0.00
5310000 - Office Supplies	1,115	1,115	712	750	1,615	0	1,615	1,115	1,615	500.00	44.84
5320000 - Operating Supplies	500	500	0	387	0	0	0	500	0	-500.00	-100.00

Comparative Budget Worksheet By Object

Object	2006 Adopted Budget	2006 Current Budget	2006 YTD Actuals	2006 Current Year Est.	2007 Dept Request	2007 Service Package	2007 Proposed Budget	2007 Base Budget	2007 Final Budget	Change in Budget	Pct Chg
5350000 - Small Tools/Minor Equipment	1,450	1,450	15	450	1,450	0	1,450	1,450	1,450	0.00	0.00
5360000 - Software/Upgrades/Licenses	500	500	0	500	500	0	500	500	500	0.00	0.00
5410000 - Professional Services	722,171	1,029,823	119,047	741,499	858,019	0	858,019	722,171	858,019	-171,804.00	-16.68
5420000 - Telephone	0	0	88	100	0	0	0	0	0	0.00	0.00
5430000 - Travel(Lodge,meals,miles,Food)	2,000	2,000	702	1,615	2,000	0	2,000	2,000	2,000	0.00	0.00
5480000 - Repairs & Maintenance	0	19,074	40,815	40,815	0	0	0	0	0	-19,074.00	-100.00
5491000 - Dues, Subscriptions	150	150	186	200	150	0	150	150	150	0.00	0.00
5492000 - Filing,Recording,Witness Fees	0	0	348	0	0	0	0	0	0	0.00	0.00
5494000 - Registration/Training/Admissn	1,800	1,800	685	1,000	1,800	0	1,800	1,800	1,800	0.00	0.00
5510000 - Intergovt Professional Service	0	0	37,275	36,166	0	0	0	0	0	0.00	0.00
5610000 - Land	20,000	20,000	0	0	0	0	0	20,000	0	-20,000.00	-100.00
5630000 - Other Improvements	299,000	328,786	84,653	237,094	0	0	0	299,000	0	-328,786.00	-100.00
5640000 - Machinery & Equipment	0	0	19,607	19,607	0	0	0	0	0	0.00	0.00
5650000 - Construction of Fixed Assets	0	0	0	0	2,656,644	0	2,656,644	0	2,656,644	2,656,644.00	0.00
5910000 - Interfund Chg-Equip Replacemnt	387	387	387	1,200	387	0	387	387	387	0.00	0.00
5950000 - Interfund Vehicle Operat/Maint	352	352	352	352	188	0	188	188	188	-164.00	-46.59
5992000 - Contingency	0	0	0	0	0	0	0	0	0	0.00	0.00
5993000 - COLA Contingency	844	844	0	0	0	0	0	844	0	-844.00	-100.00
Total Expense Accounts:	1,322,748	1,679,260	416,196	1,333,809	3,849,254	0	3,849,254	1,376,606	3,849,254	2,169,994.36	129.22
Total SWM Enterprise Fund:	6,387,676	6,925,039	3,175,059	3,069,835	5,895,207	53,750	5,948,957	4,098,023	5,948,957	-976,080.84	-14.09
Department 27 Public Works											
<i>Expense Accounts</i>											
5310000 - Office Supplies	500	500	0	500	500	0	500	500	500	0.00	0.00
5320000 - Operating Supplies	1,000	1,000	269	1,000	1,000	0	1,000	1,000	1,000	0.00	0.00
5321000 - Fuel Consumed	43,125	43,125	34,362	48,125	74,363	0	74,363	67,863	74,363	31,238.00	72.43
5350000 - Small Tools/Minor Equipment	0	0	14	0	0	0	0	0	0	0.00	0.00
5410000 - Professional Services	100	100	0	100	100	0	100	100	100	0.00	0.00
5450000 - Operating Rentals & Lease	500	500	0	500	500	0	500	500	500	0.00	0.00
5480000 - Repairs & Maintenance	43,492	43,492	17,914	38,492	63,525	0	63,525	55,525	63,525	20,033.00	46.06
5510000 - Intergovt Professional Service	0	0	0	0	0	0	0	0	0	0.00	0.00
Total Expense Accounts:	88,717	88,717	52,559	88,717	139,988	0	139,988	125,488	139,988	51,271.00	57.79
Total Vehicle Operations/Maintenance:	88,717	88,717	52,559	88,717	139,988	0	139,988	125,488	139,988	51,271.00	57.79
Department 16 Finance											
<i>Expense Accounts</i>											
5340000 - Supplies Packaged for Resale	0	0	0	0	0	0	0	0	0	0.00	0.00
5350000 - Small Tools/Minor Equipment	58,600	58,600	7,399	48,000	36,000	0	36,000	50,000	36,000	-22,600.00	-38.56
5630000 - Other Improvements	0	0	0	0	0	0	0	0	0	0.00	0.00
5640000 - Machinery & Equipment	79,580	79,580	38,505	70,000	64,000	0	64,000	50,000	64,000	-15,580.00	-19.57
5650000 - Construction of Fixed Assets	0	0	0	0	0	0	0	0	0	0.00	0.00

Object	2006 Adopted Budget	2006 Current Budget	2006 YTD Actuals	2006 Current Year Est.	2007 Dept Request	2007 Service Package	2007 Proposed Budget	2007 Base Budget	2007 Final Budget	Change in Budget	Pct Chg
Total Expense Accounts:	138,180	138,180	45,904	118,000	100,000	0	100,000	100,000	100,000	-38,180.00	-27.63
Total Equipment Replace/Deprec Fund:	138,180	138,180	45,904	118,000	100,000	0	100,000	100,000	100,000	-38,180.00	-27.63
Department 16 Finance											
<i>Expense Accounts</i>											
5510000 - Intergovt Professional Service	10,000	10,000	17,097	30,000	10,000	0	10,000	10,000	10,000	0.00	0.00
Total Expense Accounts:	10,000	10,000	17,097	30,000	10,000	0	10,000	10,000	10,000	0.00	0.00
Total Unemployment Fund:	10,000	10,000	17,097	30,000	10,000	0	10,000	10,000	10,000	0.00	0.00
Report Total	79,439,713	92,858,907	44,346,009	91,753,074	67,947,718	258,450	68,206,170	76,412,559	68,206,170	-24,652,735.00	0.00

Expenditure Categories

Object	Description
<u>Salaries and Wages</u>	
	Amounts paid for personal services rendered by employees in accordance with the rates, hours, terms and conditions authorized by law or stated in employment contracts. Personal services do not include fees and out of pocket expenses for professional or consultant services. Amounts charged to these accounts represent expenditures generated through the City's payroll process. Amounts paid to temporary help through another source than payroll does not get charged to these accounts.
5110	Salaries & Wages Employee time will be allocated within the department on a percentage basis and then paid based on that allocation throughout the year unless there is a major shift in employee responsibilities or job duties during the year.
5111	Salaries - Extra Help Hourly staff and temporary help that are not designated positions. All agency staff should be budgeted under Professional Services.
5112	Overtime Overtime pay for employees who are eligible.
5112100	Overtime - Extra Help
5113	Standby Pay Standby pay for employees who are eligible.
5114	Call Back Pay
<u>Personnel Benefits</u>	
5212	Social Security Replacement Program
5213	Soc. Sec. Replac. Prog. - Extra Help
5214	PERS
5214001	CM Retirement Plan
5215	Insurance Premium Allowance
5220	Medicare
5221	Medicare - Extra Help
5230	Labor & Industries
5231	Labor & Industries - Extra Help
5240	Unemployment Compensation
<u>Supplies</u>	
5310	Office Supplies Paper, forms, maps, publications, writing materials, Office Supplies-Boise Cascade, Corp Express (except furniture), Paper Zone
5320	Operating Supplies Chemicals, cleaning & sanitation supplies, clothing, construction materials & supplies, drugs, electrical supplies, medicines, oil, paints, and plumbing supplies
5321	Fuel Consumed
5330	Program Supplies Art supplies, sports equipment, clipboards, first aid supplies, name tags, other program related supplies, fees for admission tickets used in programs, food used as a component of a program. Room Rental - see 5450 Food & Meals - see 5430
5340	Supplies Packaged for Resale T-Shirts, food, towels, swimming goggles, other items purchased for resale/revenue Pool Resale Supplies
5350	Small Tools and Minor Equipment

Expenditure Categories

Object	Description
5360	Tools and equipment that are not capitalized (less than \$5,000) Software/Licenses/Upgrades Software & Software Licenses
<u>Other Services & Charges</u>	
5410	Professional Services Accounting/Auditing, Engineering/architectural, computer programming, management consulting, special legal services, custodial & cleaning, temporary help employed through an agency (i.e., Molly Brown, Waldron Resources), etc.
5420	Telephone Local, long-distance, and wireless
5425	Postage/Courier Postage, Fedex, UPS, Bucky's, West Courier
5430	Travel (Lodging, Meals, Miles) Per diem, lodging, meals, mileage
5440	Advertising
5450	Operating Rentals & Leases Room rentals, lease of copy or postage machines, rental of equipment Meeting Facilities Shoreline School District (Shoreline Center Room Rentals) <i>Related food costs greater than \$50 should be coded 5330 for non-events, 5430 for employee related events</i>
5460	Insurance
5471	Utility - Electricity
5471001	Utility - Electricity, Streetlights
5471002	Utility - Electricity, Traffic Signal
5472	Utility - Water
5473	Utility - Natural Gas
5474	Utility - Sewer
5475	Utility - Garbage/Solid Waste
5480	Repairs & Maintenance Buildings, improvements, structures, equipment (vehicles, tires, etc.) Maintenance Contracts All supplies purchased directly by City goes under Operating Supplies except software/licenses
5491	Dues, Subscriptions, Memberships
5492	Filing, Recording & Witness Fees Jury or witness fees
5493	Printing & Binding Copying costs, printing services, etc. Kinko's Printing Companies (brochures, newsletters, publications)
5494	Registration/Training Registration for conferences and training expenses
5495	City Grants to other Agencies Grants that the City provides to outside agencies.
5496	Judgements/Settlements
5499	Miscellaneous Expenses
<u>Intergovernmental Services</u>	
5510	Intergovernmental Professional Services Contracts or interlocal agreements between government agencies. Expenditures made to

Expenditure Categories

Object	Description
	other governmental entities for services rendered. Limited to those functions normally provided by governments and not by private businesses (police, detention, election services, animal control, etc.)
<u>Capital Outlay (Amounts should be in excess of \$5,000)</u>	
5610	Land Land acquisition costs, rights-of-way, LIDs
5620	Buildings & Structures Acquisition, construction, and improvements to office or administrative buildings, shops and warehouses, park buildings
5630	Other Improvements Athletic fields, bridges, water and sewer systems, lighting, parking, roadways, sidewalks, storm drains, streets
5640	Machinery & Equipment Communications equipment, transportation equipment, office furniture & equipment, computers, heavy duty work equipment
5650	Construction of Fixed Assets For capital improvement projects on City owned property
5660	Capitalized Rentals & Leases
<u>Debt Service</u>	
5700	Debt Service Principal
5800	Debt Service Interest
5870	Residual Equity Trans-Out
<u>Interfund Payment for Services, Transfers, and Reserves</u>	
	Expenditures made to other funds or other departments of the same fund for services rendered
5901	Interfund Professional Services (Building Permits)
5910	Interfund Charge - Equipment Replacement
5950	Interfund Vehicle Operations and Maintenance
5970	Operating Transfers Out
5992	Merit Contingency
5993	COLA Contingency Funds set-aside for the next years cost of living adjustment
5994	Operational Contingency Funds set-aside as an annual operational contingency
5995	Other Reserves Reserves set-aside for specific purposes

Glossary of Budget Terms and Acronyms

ACCOUNT. A chronological record of public funds showing receipts, disbursements, and the balance.

ACCOUNTING SYSTEM. The total set of records and procedures used to record, classify, and report information on the financial status and operations of an entity.

ACCRUAL BASIS ACCOUNTING. A method of accounting for revenues and expenses when earned or incurred instead of when cash is received or spent.

ACTUALS. Monies which have already been used or received as opposed to budgeted monies which are estimates of possible funds to be spent or received.

ADOPTED BUDGET. The budget for the operations of regular City services and for capital expenditures for the fiscal year as proposed by the City Manager and adjusted and adopted by the City Council. The adopted budget can only be adjusted (amended) during the fiscal year by an ordinance of the City Council.

AGENCY FUND. A fund used to account for assets held by a government as an agent for individuals, private organizations, other governments and/or other funds.

APPROPRIATION. A legal authorization granted by the City Council to make expenditures and to incur obligations for a specific purpose or program. Usually granted for a one-year period.

APPROPRIATION ORDINANCE. The official enactment by the City Council giving the legal authority for City officials to obligate and expend resources.

ASSESSED VALUATION. The estimated value placed upon real and personal property by the County Assessor as the basis for levying property taxes.

B.A.R.S. The State of Washington prescribed Budgeting, Accounting, and Reporting System manual for which compliance is required for all governmental entities in the State of Washington.

BALANCED BUDGET. A budget in which planned expenditures do not exceed projected funds available.

BASE BUDGET. The ongoing cost to maintain the current level of service.

BASIS OF ACCOUNTING. A fund's basis of accounting determines when a transaction is recognized in the fund's operating statement. Annual appropriated budgets for all funds are prepared and adopted on a cash basis. Under a cash basis, transactions are recognized only when cash is increased or decreased. Governmental fund financial statements are prepared on the modified accrual basis of accounting. Revenues are recognized when measurable and available to finance current expenditures and expenditures are recognized when goods and services are received and liabilities are due and payable at year-end. Under the accrual basis of accounting, the revenues are recognized in the accounting period in which they are earned and become measurable and expenses are recognized in the period incurred.

BEGINNING FUND BALANCE. The resources that are unspent from the previous year and are available in the subsequent fiscal year for expenditure. Since these resources are typically available due to under-expenditures in the previous year or unexpected revenues, it is prudent to not utilize these resources for ongoing operational expenditures.

BENEFITS. City provided employee benefits such as social security replacement, retirement, worker's compensation, life insurance, medical insurance and dental insurance.

BUDGET. A plan of financial operation embodying an estimate of expenditures for a given period and the proposed means of financing them (revenue estimates). The term is also sometimes used to denote the officially approved expenditure ceilings under which the City and its departments operate.

BUDGET CALENDAR. The schedule of key dates or milestones which the City follows in the preparation and adoption of the budget.

BUDGET HEARING. A public hearing conducted by City Council to consider and adopt the annual budget.

CAPITAL BUDGET. Major capital improvements which are beyond the routine operation of the city are budgeted under separate capital project funds. These projects often require more than one year to complete. In total, these projects are referred to as the Capital Budget and are not included in the annual operating budget.

CAPITAL IMPROVEMENT CONSTRUCTION. Projects such as roads, drainage, buildings, sidewalks and other works to create and repair the City's physical infrastructure; funds in this category may also be used for the design, project management and other associated administrative costs.

CAPITAL IMPROVEMENT PROGRAM. A six-year plan for capital expenditures that identifies the expected beginning and ending date of each project, the amount to be expended in each year on each project and the method of financing project expenditures.

CAPITAL OUTLAYS. Annual operating expenditures for the acquisition of, or addition to, fixed assets. These expenditures must cost more than \$5,000, including construction projects, land acquisition, major renovations or repairs to existing grounds or facilities, and equipment purchases.

CAPITAL PROJECTS. Projects which purchase or construct capital assets. Typically a capital project encompasses a purchase of land and/or the construction of a new building or facility. It may also include major maintenance or renovation of a current asset.

CASH BASIS ACCOUNTING. The method of accounting where revenues are recorded when received and expenditures are recorded when paid.

CASH RESERVES. The cash balance that is not appropriated for expenditures or that is segregated by policy for a specific future use.

CHARGES FOR GOODS AND SERVICES. A basic classification for services other than personnel services which are needed by the City. This budget item includes professional services, communication, travel, advertising, rentals and leases, insurance, public utility services, repairs and maintenance, and miscellaneous.

CLEAN WATER ACT (CWA). In 1972, Congress amended the Federal Water Pollution Control Act (referred to as the Clean Water Act) to prohibit the discharge of any pollutant to waters of the United States from a point source unless the discharge is authorized by a National Pollutant Discharge Elimination System (NPDES) permit. In 1999 the US Environmental Protection Agency promulgated rules (NPDES Phase II) that sets storm water management requirements for municipalities under 100,000 population, including the City of Shoreline.

CONSUMER PRICE INDEX (CPI). A statistical measure of price levels provided by the U.S. Department of Labor signifying the cost of living and economic inflation.

CONTINGENCY. A budgetary reserve set aside for emergencies or unforeseen expenditures.

COUNCILMANIC BONDS. Bonds issued with the approval of the City Council, as opposed to bonds which must be approved by public vote. Councilmanic bonds must not exceed 1.5 percent of the assessed valuation.

CRITICAL SUCCESS FACTORS. Areas where the City has to excel, if it is to accomplish the community's vision.

DEBT SERVICE. The annual payment of principal and interest on the City's indebtedness.

DEFICIT. The excess of the liabilities of a fund over its assets. The excess of expenditures over revenues during an accounting period; or, in the case of proprietary funds, the excess of expense over income during an accounting period.

DEPRECIATION. (1.) Expiration in the service of life of capital assets attributable to wear and tear, deterioration, action of the physical elements, inadequacy, or obsolescence. **(2.)** That portion of the cost of a capital asset which is charged as an expense during a particular period.

ENCUMBERANCE. The commitment of appropriated funds to purchase an item or service.

ENDANGERED SPECIES ACT (ESA). Refers to the listing of the Puget Sound chinook salmon as a threatened species by the National Marine Fisheries Service. Potentially affects all sensitive areas, and stormwater regulations for both quality and quantity.

ENDING FUND BALANCE. The cash balance remaining at the end of the fiscal year available for appropriation in future years.

EXPENDITURES. Where accounts are kept on the accrual or modified accrual basis of accounting, the costs of goods received or services rendered whether cash payments have been made or not. Where accounts are kept on a cash basis, expenditures are recognized only when the cash payments for the above purposes are made.

FEES. A charge for a service the City does not provide for free to all citizens. For example, we have fees for recreation classes or land use development applications.

FISCAL YEAR . Any yearly accounting period, without regard to its relationship to a calendar year. The fiscal year for the City of Shoreline begins on January 1 and ends on December 31.

FTE. An acronym for Full-Time Equivalents, which are regular, full-time employee positions; when expressed as a decimal number, this means that only part of a full-time employee position is dedicated to this service or program within the budget.

FUNDS. Funds are comprised of special accounts within the City budget that are used to segregate revenues and expenditures for specific types of programs and services and to comply with State law and generally accepted accounting principles (GAAP).

FUND BALANCE. The excess of an entity's assets over its liabilities in a particular fund. A negative fund balance is sometimes called a deficit.

GENERAL FUND. This fund is used to pay the expenses and liabilities of the City's general services and programs for citizens that are not separately accounted for in special revenue funds.

GENERAL FUND SUBSIDY. This reflects the amount of General Fund discretionary taxes required to fund a department's budget. The formula for this figure is total departmental expenditures minus dedicated resources (grants, fees, etc.) equals General Fund subsidy.

GENERAL OBLIGATION BONDS. Bonds for which the full faith and credit of the issuing government are pledged for payment.

GRANTS. Funds provided to or by the City for special purposes or programs, usually requiring a competitive application process.

INFRASTRUCTURE. The underlying foundation, especially the basic installations and facilities, on which the continuance and growth of a jurisdiction depends, i.e., streets, roads, sewer, and water systems.

INTERFUND TRANSFERS. Contributions from one City fund to another in support of activities of the receiving fund. Loans are not included.

INTERGOVERNMENTAL REVENUE. Grants, entitlements, shared revenues and payment for goods and services by one government to another.

INTERGOVERNMENTAL SERVICES. Services purchased from other government agencies, normally including types of services that only government agencies provide.

INTERNAL SERVICE FUNDS. A type of proprietary fund which accounts for the goods and services which are provided to other units of the City and payment by the benefiting unit is intended to fund the costs of providing such services.

LEVEL OF SERVICE. Used generally to define the existing services, programs, and facilities provided by the government for its citizens. Level of service in any given activity may be increased, decreased, or remain the same, depending on the needs, alternatives, and available resources.

LEVY. To impose a tax, special assessment or service charge for the support of government activities. The term most commonly refers to the real and personal property tax levy.

LEVY RATE. The rate at which taxes, special assessments or service charges are imposed. For example, the real and personal property tax levy is the rate at which property is taxed per \$1,000 of assessed valuation. The rate is determined by calculating the ratio of the maximum amount of property tax revenue allowable under state law and the total assessed valuation within the taxing district.

LIABILITY. Debt or other legal obligation arising out of transactions in the past which must be liquidated, renewed or refunded at some future date.

MODIFIED ACCRUAL ACCOUNTING. A basis of accounting in which expenditures are accrued but revenues are accounted for on a cash basis. This accounting technique is a combination of cash and accrual accounting since expenditures are immediately incurred as a liability while revenues are not recorded until they are actually received or are "measurable" and "available for expenditure". Since this type of accounting basis is a conservative financial approach, it is recommended as the standard for most governmental funds.

NON-DEPARTMENTAL EXPENDITURES. Expenditures that are not directly related to the operations of a single City department.

OBJECT OF EXPENDITURE. Expenditure classifications based upon the types or categories of goods and services purchased. Typical objects of expenditure include salary, benefits, supplies, other services and charges, intergovernmental services, inter-fund payment for services, capital outlay and debt service.

OPERATING BUDGET. The annual appropriation to maintain the provision of City services to the public.

OPERATING FUNDS. These funds account for the day-to-day operations of providing City services. They do not include capital improvements. They include the General Fund and Special Revenue Funds.

OPERATING TRANSFER IN. Transfer from other funds which are not related to rendering of service.

OPERATIONAL CONTINGENCY. Funds set-aside in the General Fund budget to provide for unknown operational adjustments or service demands that may arise during the year. These funds are used only as a last resort and with Council approval. Savings within departmental budgets throughout the year will be the first source for funding unforeseen expenditures.

OVERHEAD/INDIRECT COSTS. Overhead or indirect costs represent the level of assistance that the support service departments (Finance, Human Resources, City Manager, etc.) provide to the direct service departments (Police, Parks, Public Works, etc.) so they can provide services to the public.

PERFORMANCE MEASURES. A performance measure is an indicator of the attainment of an objective. It is a specific quantitative measure of work performed or services provided within an activity or program, or it may be a quantitative measure of results obtained through a program or activity.

PERS. Acronym for Public Employees Retirement System provided for all City employees, other than law enforcement and fire fighter personnel, by the State of Washington.

PROGRAM. A broad function or area of responsibility of government services. It is a basic organizational unit of government that is composed of a group of specific activities and operations directed at attaining a common purpose or goal.

PROGRAM PURPOSE. A broad declaration of purpose explaining why the program exists and what we hope to achieve with the resources invested.

PROPOSED BUDGET. The City Manager's recommended budget submitted to the City Council and public in October of each year.

PROPRIETARY FUNDS. Recipients of goods or services pay directly to these funds. Revenues are recorded at the time services are provided, and all expenses incurred in earning the revenues are recorded in the same period. As a result, there is a direct cause and effect relationship between revenue and expenses in these funds.

PROPOSED BUDGET. This is the budget, as proposed by the City Manager, for the operations of regular City services and for capital expenditures.

REAPPROPRIATION. A legal authorization granted by the City Council to re-appropriate expenditures to the current budget year for a specific purpose or program that was budgeted but unexpended at the end of the prior year.

REET. The Real Estate Excise Tax, a tax levied on real estate sales and used solely for capital purposes.

RESERVES. The funds set aside by the City as a savings account for future emergencies. The City's reserves include the General Reserve Fund, the Insurance Reserve budgeted in Citywide Services, and a General Fund Undesignated Ending Fund Balance.

RESOURCES. Total dollars available for appropriations including estimated revenues, fund transfers and beginning fund balances.

REVENUES. Income received by the City to support programs or services to the community. It includes such items as taxes, fees, user charges, fines, forfeits, interest income and miscellaneous revenue.

SALARIES AND WAGES. Amounts paid for services rendered by employees in accordance with rates, hours, terms and conditions authorized by law or stated in employment contracts. This category also includes overtime and seasonal help.

SPECIAL ASSESSMENT. A compulsory levy made against certain properties from earnings of enterprise funds. An addition to a pledge or revenues, such bonds sometimes contain a mortgage on the enterprise funds property.

SPECIAL REVENUE FUNDS. Funds that are dedicated for a specific purpose (e.g., roads, surface water, etc.), require an additional level of accountability and are collected in a separate account, not part of the General Fund.

STRATEGIC GOALS. Each critical success factor has a targeted number of strategic goals. These goals are customer-oriented and are connected to the budget, the capital improvement program (CIP), and the comprehensive plan. They are measurable, realistic, and focused.

STRATEGIC PLAN. A plan outlining the goals and strategies the City will focus on over the next six years. It is prioritized around the critical success factors of our community and is intended to be a living document, which will be evaluated regularly.

SUBSIDIES. Financial assistance provided by one agency to another agency for a defined purpose (e.g., King County swimming pool subsidies, General Fund subsidy of the Street Fund transportation programs).

TAXES. Compulsory charges levied by a government for the purpose of financing services performed for the common benefit. This term does not include special assessments, fees, or charges for services.

TAX LEVY. Charge levied by a government to finance services performed for the common benefit.

TAX RATE. The amount of tax stated in terms of units per \$1,000 of assessed value of taxable property. The tax rate is the result of dividing the tax levied by the assessed value of the taxing district.

TRANSFERS IN/OUT. Resources that are transferred from one fund to another to pay for a specific purpose. For example, resources are transferred from the Surface Water Fund to the Surface Water Capital Fund to pay for surface water related capital improvement projects, since all capital projects are expensed out of the capital improvement funds.

UNRESERVED/UNDESIGNATED FUND BALANCE. That portion of available fund balance that has not been designated or restricted for a specific purpose and is available for general appropriation.