

TYPICAL TRAFFIC CIRCLE

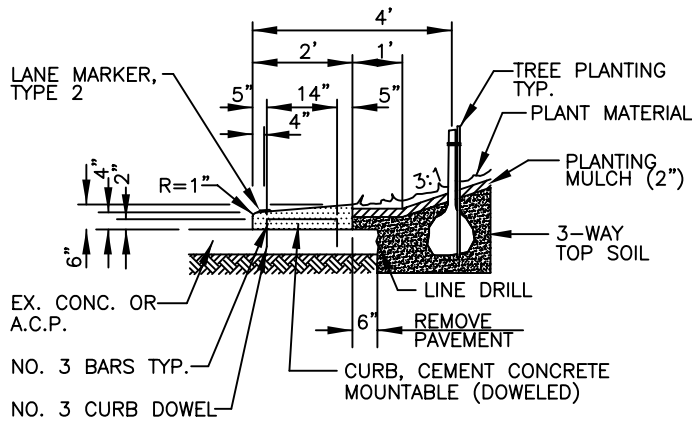

TYPICAL SECTION A

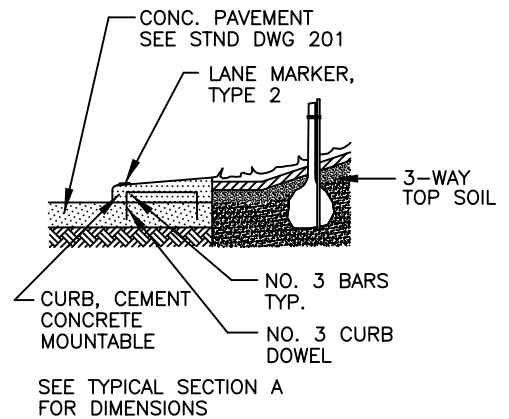

TYPICAL SECTION B

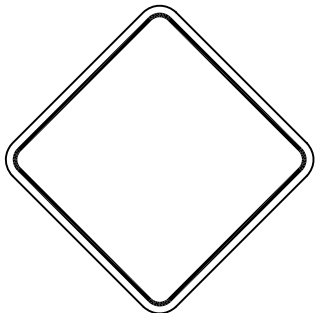

30" x 30" BLACK ON YELLOW
PLACED IN CENTER OF TRAFFIC
CIRCLE ON EACH APPROACH.

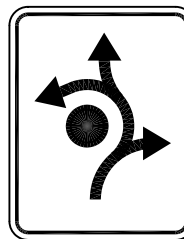

24" x 30" BLACK ON WHITE
PLACED 50' - 100' BACK
FROM TRAFFIC CIRCLE ON
SPECIFIED APPROACH.



Public Works
Planning
and
Development
Services

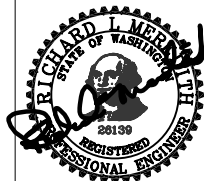

Traffic Circle Details

211

NOT TO SCALE

Revision Date
December 2006