

**SECTION A-A**

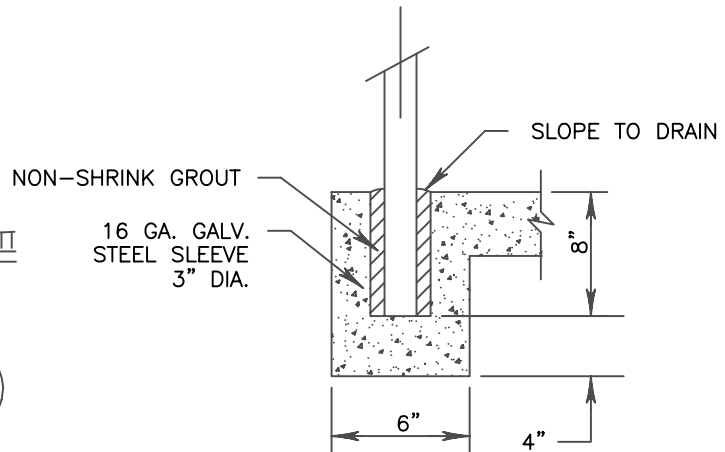

**POST DETAIL**

**NOTES:**

1. CEMENT CONCRETE STEPS AND CURBS SHALL BE CONSTRUCTED AS SHOWN ON STND DWG 325.
2. HEIGHT OF RAILING SHALL BE 36" MINIMUM, 38" MAXIMUM TOP OF NOSING TO TOP OF RAILING.
3. PEDESTRIAN RAILING SHALL BE CONSTRUCTED AS SHOWN ON STND DWGS 323 & 324.
4. CLEAR SPACE BETWEEN BALUSTERS SHALL BE A MAXIMUM OF 4".
5. ALL STEPS SHALL HAVE HANDRAIL ON BOTH SIDES.



Public Works  
Planning  
and  
Development  
Services

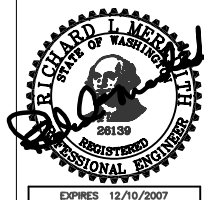

**Cement Concrete  
Stairway**

**326**

NOT TO SCALE

Revision Date  
December 2006