

ELEVATION NOTE: HEIGHT VARIES,
SEE CHAPTER 3, ENGINEERING DEVELOPMENT GUIDE

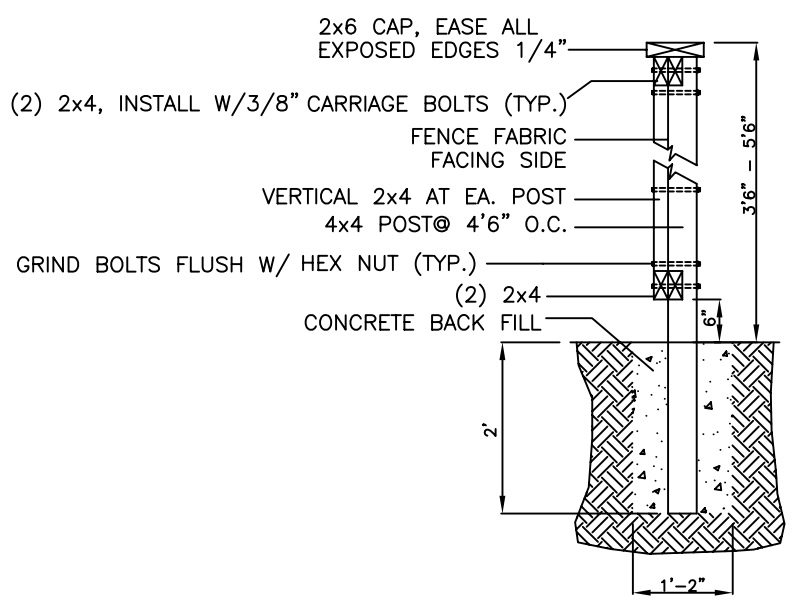

SECTION

NOTE: DIAGONAL BRACE RAILS (4x4) TO BE INSTALLED AT ALL END SECTIONS, TOP OF BRACE AT TOP OF END SECTION/CORNER.

	<p>Public Works Planning and Development Services</p>		<h1 style="margin: 0;">Greenbelt Fence</h1>	<h1 style="margin: 0;">335</h1>
				<p>NOT TO SCALE</p>
				<p>Revision Date December 2006</p>