

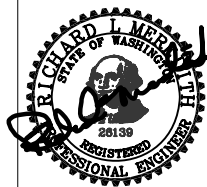

Public Works
Planning
and
Development
Services



Standard Grate

729

NOT TO SCALE

Revision Date
December 2006

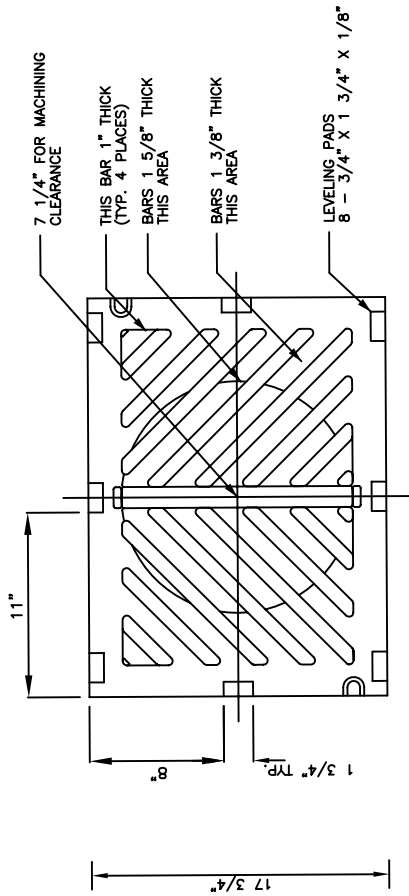

BOTTOM VIEW

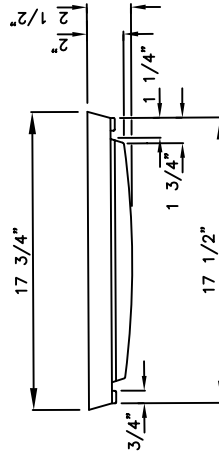

END VIEW

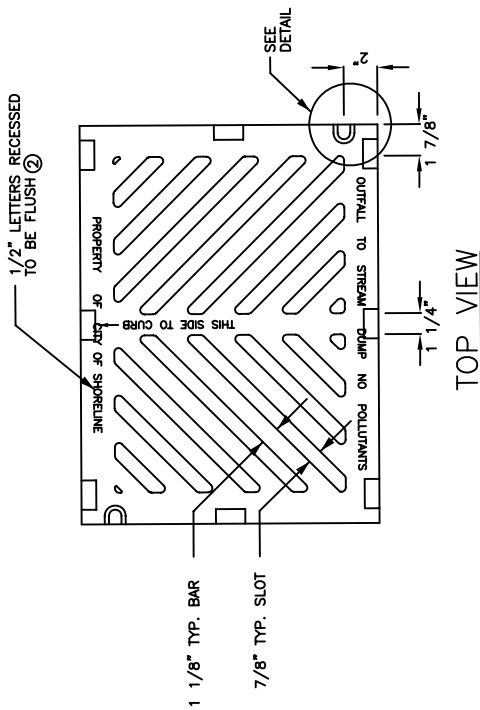

TOP VIEW

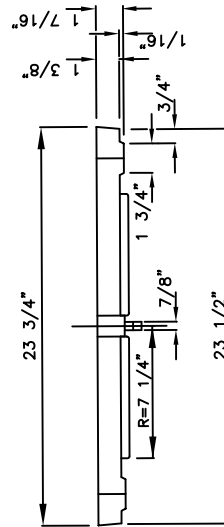

SIDE VIEW

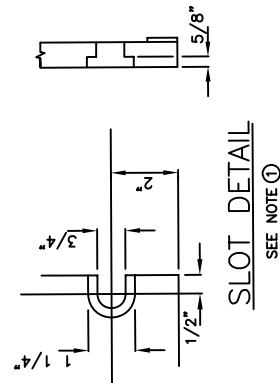

SLOT DETAIL

SEE NOTE ①

NOTES:

- ① SLOT FORMED AND RECESSED FOR 5/8"-11 NC X 2" SOCKET HEAD (ALLEN HEAD) CAP SCREW.
- ② THE WORDS "PROPERTY OF CITY OF SHORELINE" SHALL BE OMITTED IF GRATE IS ON PRIVATE SYSTEM.
3. ALL CASTINGS SHALL HAVE A BITUMINOUS COATING.
4. GRATE SHALL BE CAST IRON PER ASTM A48 CLASS 30 UNLESS OTHERWISE SPECIFIED.