

PLAN

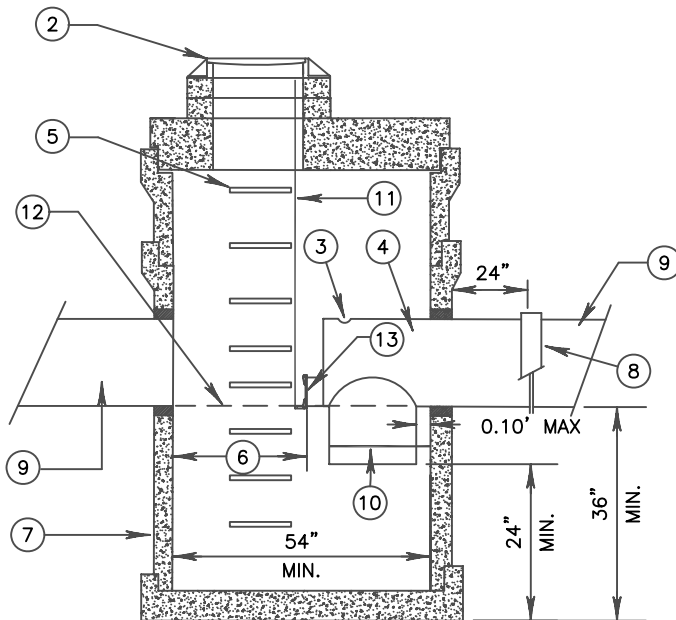

ELEVATION

NOTES:

- ① INSTALL MANHOLE ACCESS SO THAT LIFT GATE IS VISIBLE THROUGH OPENING AND STEPS CLEAR INLET AND RESTRICTOR UNIT.
- ② INSTALL STND DWG 721 WITH LOCKING COVER OR WHEN IT IS TO BE A CB THEN USE STND DWG 707.
- ③ 1" VENT HOLE.
- ④ SEPARATOR ASSEMBLY.
- ⑤ HANDHOLDS: SEE STND DWG 709.
- ⑥ MIN CLEARANCE:
36" FOR OUTLETS OF 24" AND LARGER
18" FOR OUTLETS OF 18" AND SMALLER
- ⑦ 54" TYPE 2 CB OR LARGER.
- ⑧ BAND STRAP WITH GASKET.
- ⑨ SEE PLAN AND SPECIFICATIONS FOR SIZE AND TYPE OF PIPE ENTERING AND EXITING CB.
- ⑩ SECURE SEPARATOR TO CB WITH 8 GA ALUMINUM STRAP. BOLT TO CB WALL WITH STAINLESS STEEL ANCHOR BOLTS AND TACK WELD TO SEPARATOR UNIT.
- ⑪ LIFT HANDLE SEE STND DWG 762.
- ⑫ INV. EL. : SEE PLANS AND SPECIFICATIONS.
- ⑬ CLEAN OUT AT 8" DIA. MIN.
12" FOR 24" DIA. AND LARGER
OUTLET PIPE.
- ⑭ GROUT ALL JOINTS INSIDE AND OUTSIDE.



Public Works
Planning
and
Development
Services

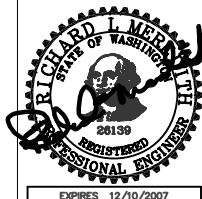

**Floatable Material
Separator - 12" & Larger**

766

NOT TO SCALE

Revision Date
December 2006